



The Paramount Robotic Telescope System User Guide

Paramount MYT, MX, MX+ and ME II German equatorial mount models

Revision 2.2 December, 2016



Information in this document is subject to change without notice and does not represent a commitment on the part of Software Bisque. The software products described in this document are furnished under a license agreement or nondisclosure agreement. They may be used or copied only in accordance with the terms of the agreement. It is against the law to copy the software on any medium except as specifically allowed in the license or nondisclosure agreement. The purchaser may make one copy of the software for backup purposes.

No part of this manual and/or databases may be reproduced or transmitted in any form or by any means, electronic or mechanical, including (but not limited to) photocopying, recording, or information storage and retrieval systems, for any purpose other than the purchaser's personal use, without the express written permission of Software Bisque, Inc.

Software Bisque
862 Brickyard Circle
Golden, CO 80403-8058
USA

Web Site: <http://www.bisque.com>

The Paramount ME, Paramount ME II, Paramount MX, Paramount MX+, Paramount MyT, Bisque TCS, MKS 4000, MKS 5000, and TheSkyX Professional Edition Astronomy Software are trademarks of Software Bisque, Inc.

All other product names are trademarks of their respective owners and are used solely for identification.

Table of Contents

Telescope Operation Disclaimer	8
Sun Warning.....	8
The Paramount Robotic Telescope System	9
Paramount Model Comparison.....	12
Optional Accessories.....	14
Getting Help.....	15
What You Need to Know.....	16
Coordinate Systems	16
The Horizon Coordinate System	16
The Equatorial Coordinate System	17
Hour Angle	19
Local Sidereal Time	19
Atmospheric Refraction.....	20
Polar Alignment Basics.....	21
Homing.....	22
Labeling the Home Position on the Sky Chart.....	24
Physically Marking the Home Position.....	25
Synchronization	26
Best Synchronization Practices	27
Step by Step Synchronization	27
Session to Session Pointing Repeatability.....	28
Making Sure Synchronization Is Correct	29
The Local Celestial Meridian	30
Maintaining Accurate Time.....	31
Parking the Paramount	31
Parking from TheSkyX Professional Edition	32
Defining the Park Position.....	32
Park Position Rules.....	32
Audible Control System Feedback	33
Visual Control System Feedback	35

Through the Mount Cabling.....	35
Packing List.....	42
Box 1 Contents	42
Important Packing Material Notes.....	44
Box 2 Contents (Accessories Box)	45
Locating Your Serial Numbers.....	48
Paramount and Software Serial Number Registration	49
Unpacking the Paramount	49
Your Safety is Paramount.....	49
Paramount ME II Unpacking Insert	50
Paramount MX Unpacking Insert.....	51
Paramount MX+ Unpacking Insert.....	52
Paramount MyT Unpacking Insert	53
Packing the Paramount for Transport	55
Paramount Components.....	56
Paramount ME II Front View.....	57
Paramount MX Front View	58
Paramount MX+ Front View	59
Paramount MyT Front View.....	60
RA Worm Block Cover	60
Payload Mounting Plate (Versa-Plate).....	61
Paramount Versa-Plate Knobs	64
Large Dovetail Accessory Rail (Paramount ME II only, Optional Accessory)	69
Instrument Panel.....	69
RA Worm Block Cover	73
RA Cable Conduit	74
RA Gear Cover (ME II Only)	74
Dec Cable Conduit.....	74
Right Ascension Carrying Handle	74
RA Worm Block Switch.....	74
RA Spring Plunger and Cam Stop Access Hole (Paramount ME II and MX+ Only).....	79
RA Encoder Cover (Paramount ME II Only).....	79

RA Assembly..... 79

Electronics Box..... 79

Polar Axis Adjustments 83

Azimuth Adjuster Knobs 84

 Base Thrust Mounting Knobs..... 86

 Base Plate..... 86

Paramount ME II Rear View 87

Paramount MX Rear View..... 88

Paramount MX+ Rear View..... 89

 Declination Carrying Handle (Paramount MX Only) 90

 Declination Axis Three Position Switch (Paramount MX Dec Three Position Switch) 90

 Cable Conduit Access Hole and Cover 90

 Right Ascension Axis Locking Hole (Paramount ME II Only) 91

 Configurable Hard Stop Positions (Paramount ME II Only) 92

 Declination Axis Assembly (Dec Assembly)..... 92

 Paramount Serial Number (Serial Number)..... 93

 Altitude Scale 93

 Altitude Adjuster 95

 Counterweight Shaft 100

 Counterweight Shaft Extension Bar (Optional)..... 101

 Counterweights..... 101

 Payload Imbalance Cause and Effect 104

 Balancing the Payload 104

 Counterweight Safety Knob 105

Paramount ME II Side View..... 106

Paramount MX Side View 107

Paramount MX+ Side View 108

 Altitude Adjuster Thrust Knobs..... 109

 Wedge 109

 Bubble Level 110

 Declination Axis Locking Hole (Paramount ME II Only) 111

 Micro Levelers (Paramount ME II Only)..... 111

Hand Controller.....	113
Other Paramount Accessories	114
USB Cable	114
Hex Wrenches	115
Power Supply Unit (PSU).....	115
Altitude Adjuster Wrench (Paramount ME II Only)	115
How to Polar Align	115
Rough Polar Alignment Method	116
Step-By-Step Rough Polar Alignment	116
Accurate Polar Alignment	117
The Accurate Polar Alignment Command.....	117
Using the Polar Alignment Scope.....	119
The Paramount and TheSkyX Professional Edition	120
Paramount Minimum System Requirements	120
First Time Paramount Setup	121
Paramount USB Driver Installation	122
Mac OS X	122
Windows	122
Controlling the Paramount with TheSkyX Professional Edition.....	122
Getting Started with TheSkyX Professional Edition	124
The Bisque TCS Window	125
Status Messages (Status Text)	126
Firmware Version and Mount Identifier	126
Parameters Tab.....	126
Advanced Parameters.....	129
Commands Pop-up Menu	137
Show Status Tab.....	140
Periodic Error Correction Tab	142
Bisque TCS PEC Table Tab	144
Compute PEC Curve Tab	146
Collecting and Using Periodic Error Tracking Data	148
Utilities Tab	156

On-Axis Encoders Tab (Paramount ME II only) 174

Using ProTrack™ 174

 ProTrack Minimum Requirements 175

 Getting Started with ProTrack 175

Troubleshooting Mount Operation..... 176

 USB Hubs and USB Extenders 178

 Controlling Multiple USB Devices with USB Hubs..... 178

 Windows and USB Port Power Settings 179

Appendix A: Installing the MKS 5000 USB Windows Driver 181

 Windows USB Driver Installation and Use 181

 Accessing Windows Device Manager..... 182

 Uninstalling the MKS 5000 Driver 183

Appendix B: Paramount Technical Drawings 185

 Computing Dome Offset Distance 186

Appendix C: External Power Cable Sets 189

 Apogee/QSI/SBIG ST-402/STF-8300 Model Camera External Power Cable Set Specifications 189

 SBIG ST-7 Series (5-Pin) External Power Cable Set Specifications 192

 SBIG ST-L Series (6-Pin) External Power Cable Specs..... 193

 Finger Lakes Instruments External Cable Specs..... 195

 Generic External Power Cable Specs 196

Appendix D: Paramount Warranty 198

 Product Return Procedure 198

Appendix E: Revision History 199

Index..... 203

Telescope Operation Disclaimer

Robotic telescope mounts do not have an unlimited range of movement. The telescope's shape, the way it is mounted, or the addition of accessories can prevent it from pointing at particular parts of the sky. If the telescope is forced past these points, the telescope, its mounting, or accessories might be damaged.

TheSkyX Professional Edition includes telescope limit features that let define these inaccessible positions; *TheSkyX Professional Edition*, or the mount's control system, will try to prevent the telescope from entering or crossing them. This feature is provided as a *convenience*, not as a panacea. Since any telescope can run into its mechanical limits through accident, carelessness, or component failure, Software Bisque cannot be responsible for any damage to your telescope that occurs when using *TheSkyX Professional Edition* to control it.

Furthermore, Software Bisque cannot be held responsible for damage caused by plugging cables into electronic devices. We strongly recommend turning off all electronic devices (computers, mobile devices, telescopes, focusers, dew heaters, CCD cameras, etc.) before attaching any cabling or power supplies.

Sun Warning

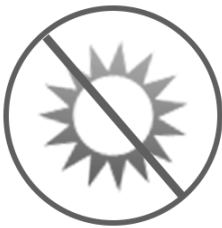

NEVER attempt to observe the Sun through your telescope! Without a specially designed solar filter, viewing the Sun – for even a fraction of a second – will cause instant, irreversible eye damage. When observing during the day, do not point the telescope near the Sun. Do not use *TheSkyX Professional Edition's* automatic slew feature to find objects during the day.

The Paramount Robotic Telescope System

Thank you for purchasing the Paramount Robotic Telescope System. The Paramount mount is an ultra-precision German equatorial mount (GEM) that is designed to deliver unmatched pointing, tracking and stability for amateur or professional astronomers in portable or permanent installations. These precision mechanics, when commanded by *TheSkyX Professional Edition*, create a formidable imaging system that can help you achieve your most lofty observing goals.

This user guide covers the basic setup and use of the *Paramount ME II*, *Paramount MX*, *Paramount MX+*, and *Paramount MYT* model mounts, as well as how to control your mount using *TheSkyX Professional Edition*.

This document assumes you are familiar with many fundamental concepts in astronomy and are somewhat experienced using a telescope and or CCD camera in conjunction with a personal computer.

If a concept presented here is new to you, consider searching the Internet to find out more information about it. Unfortunately, there is simply no way that all the different facets of setting up and controlling a robotic telescope mount can be covered in a single document.

The table below lists the significant Paramount hardware, electronics and software features that are designed to help foster memorable and productive observing experiences.

Feature	MEII	MX	MX+	MYT
Software Bisque's fourth generation dual axis control system (MKS 5000™) provides precision, reliable performance.	✓	✓	✓	✓
Integration with <i>TheSkyX Professional Edition</i> for Mac or Windows control.	✓	✓	✓	✓
<i>Camera Add On™</i> software provides single software telescope, camera, focuser, filter wheel, SBIG AO and rotator control.	✓	✓	✓	✓
<i>Dome Add On™</i> keeps the motorized dome aligned with telescope.	✓	-	-	-
<i>TPoint Add On™</i> with Super Model™ and ProTrack™ provides the same telescope pointing correction software that is used on most professional telescopes.	✓	✓	✓	✓

The <i>Multi-OS and Six License Add On</i> lets you install <i>TheSkyX Professional Edition</i> and related Add Ons on up to six (6) different Mac and Windows computers.	✓	✓	✓	✓
Research-grade right ascension gears with seven (7) arcsecond or less peak to peak periodic error <i>before</i> training PEC.	✓	✓	✓	✓
Optimal periodic error correction curve fitting that can produce “seeing indifferent” periodic error curves.	✓	✓	✓	✓
<i>Direct Guide™</i> allows optimal guiding without a guider cable.	✓	✓	✓	✓
Both the right ascension and declination axes include mechanical switches quickly switch between balancing the payload and tracking. <ul style="list-style-type: none"> • The Paramount ME II’s axes may be locked in place by installing locking bolts (page 91). • The Paramount MX includes a three position mechanical switch (page 51). • Each axis of the Paramount MX+ and Paramount MYT has two <i>separate</i> mechanical switches (page 53). 	✓	✓	✓	✓
Clutch-free worm block design preserves the mount’s physical orientation for accurate and repeatable TPoint modeled pointing and tracking.	✓	✓	✓	✓
The control system’s right ascension and declination axes can	✓	✓	✓	✓

be configured to slew and track over a wide dynamic range of tracking rates. Virtually any slew speed is available between zero and several degrees per second.				
Configurable acceleration and deceleration rates during slews.	✓	✓	✓	✓
Integrated homing sensors allow rapid mount initialization to produce precision and reliable pointing repeatability from night to night, or if power is lost.	✓	✓	✓	✓
Super-stable physical design that rapidly dampens external vibrations.	✓	✓	✓	✓
Configurable software slewing limits prevent damage to the mount and telescope by slowly decelerating to limit regions.	✓	✓	✓	✓
Fifty individual through the mount cabling conductors that help minimize the tedium of having CCD power, CCD signal, focus, video, dew heater, and other accessory cables routed to the telescope.	✓	✓	✓	✓
Integrated Cable Conduit™ allows adding custom cables, wires through the mount.	✓	✓	✓	✓
Integrated rotating base allows calibrated azimuth adjustments to be made without affecting the mount's altitude.	✓	✓	✓	✓
Integrated altitude scale to provide an accurate altitude starting point for polar alignment.	✓	✓	✓	✓
Structural design is extremely rigid, even at maximum payload capacity.	✓	✓	✓	✓

Landing lights under the mount can be turned on to illuminate dark working areas during setup.	✓	✓	✓	✓
Two counterweights and one counterweight shaft included standard.	✓	✓	✓	✓
Oversized right ascension and declination bearings provide maximum stability.	20.3 cm (8 in.)	15.2 cm (6 in.)	15.2 cm (6 in.)	11 cm (4.3 in.)
Integrated equatorial wedge for polar axis altitude adjustment.	14° – 68°	10° – 65°	10° – 65°	0° – 64°
High total instrument capacity to mount weight ratio.	109 kg/38 kg (240 lb./84 lb.)	41 kg/23 kg (90 lb./50 lb.)	45 kg/23 kg (100 lb./50 lb.)	23 kg/15.4 kg (50 lb./34 lb.)
Power supply included with mount.	200W max	80W max	80W max	80W max

Paramount Model Comparison

The Paramount ME II, Paramount MX and Paramount MX+ are very similar in function and design. The table below lists the “significant” differences between these models.

Feature or Specification	MEII	MX	MX+	MYT
Maximum payload capacity (total instrument capacity not including counterweights)	109 kg/240 lb.	41 kg/90 lb.	45 kg/100 lb.	23 kg/50 lb.
Physical dimensions	See technical drawing references on page 185.	See technical drawing references on page 185.	See technical drawing references on page 185.	See technical drawing references on page 185.

Feature or Specification	MEII	MX	MX+	MYT
Versa-Plate dimensions and optional mounting accessories (page 61)	25 cm x 51 cm x 2.5 cm (9.9-in. x 20-in. x 1.0-in) <ul style="list-style-type: none"> • Four dovetail mounting knobs. • Optional mounting rails for attaching large OTAs. 	16 cm x 41 cm x 1.8 cm (6.4-in. x 16-in x 0.72 in.) <ul style="list-style-type: none"> • Three dovetail mounting knobs. 	16 cm x 41 cm x 1.8 cm (6.4-in. x 16-in x 0.72 in.) <ul style="list-style-type: none"> • Three dovetail mounting knobs. 	15 cm x 35.6 cm x 1.6 cm (5.95-in. x 14-in x 0.63 in.) <ul style="list-style-type: none"> • Three dovetail mounting knobs.
Number of Altitude Adjuster Thrust Knobs (page 109)	Four (4)	Two (2)	Two (2)	Two (2)
Routing custom cabling through the mount	See “Through the Mount Cabling” on page 35 for details.	See “Through the Mount Cabling” on page 35 for details.	See “Through the Mount Cabling” on page 35 for details.	See “Through the Mount Cabling” on page 35 for details.
Mechanical switch on right ascension and declination axes (page 74)	<p>The <i>Two Position Switch</i> engages the worm with the gear, or permits payload balance by separating the worm from the gear.</p> <p>The right ascension and declination axes can be locked in place for transport, or when adding payload, by installing two locking bolts on each axis.</p>	<p>The <i>Three Position Switch</i> engages the worm with the gear, permits payload balance by separating the worm from the gear, or locks the gears to prevent axis rotation during shipment or transport.</p>	<p>The <i>Two Position Switch</i> engages the worm with the gear, or permits payload balance by separating the worm from the gear.</p> <p>The <i>Transportation Lock Knob</i> can be placed in a lock or balance position for transportation or adding payload by pulling and rotating a mechanical switch 90 degrees for each axis.</p>	<p>The <i>Two Position Switch</i> engages the worm with the gear, or permits payload balance by separating the worm from the gear.</p> <p>The <i>Transportation Lock Knob</i> can be placed in a lock or balance position for transportation or adding payload by pulling and rotating a mechanical switch 90 degrees for each axis.</p>

Feature or Specification	MEII	MX	MX+	MYT
Physical hard stops that permit tracking past the meridian without the optical tube assembly flipping sides	Configurable. Five different positions, located at a minimum of seven minutes to up to two (2) hours past the meridian.	Fixed, non-configurable hard stop position that allows a maximum of two (2) hours tracking past the meridian.	Fixed, non-configurable hard stop position that allows a maximum of two (2) hours tracking past the meridian.	Fixed, non-configurable hard stop position that allows a maximum of two (2) hours tracking past the meridian.
Base Plate Micro Levelers	See “Micro Levelers (Paramount ME II Only)” on page 111.	Not available.	Not available.	Not available.

Optional Accessories

The table below lists optional accessories for each model.

Optional Accessory	MEII	MX MX+	MYT
Counterweight Shaft Extension Bar	8-in. long, 1.875-in. wide	8-in. long, 1.5-in. wide	Not available.
Counterweights	<ul style="list-style-type: none"> 14 kg/30 lb. 18 kg/40 lb. 1.875-in. bore	<ul style="list-style-type: none"> 9 kg/20 lb. 4.5 kg/10 lb. 1.5-in. bore	<ul style="list-style-type: none"> 9 kg/20 lb. 4.5 kg/10 lb. 1.5-in. bore
Software Bisque Permanent Pier	✓	✓	✓
Power supply cables to use in conjunction with the mount’s built-in through the mount power cabling (page 188)	✓	✓	✓
Base to Pier Adaptor Plate for mounting the Paramount to an existing pier	✓	✓	✓
Polar alignment scope, mounting hardware, and cover	✓	✓	Not available.
Pyramid™ Portable Pier	✓	✓	Not available.
Paramount Mighty Tripod	Not available.	Not available.	✓

Optional Accessory	ME II	MX MX+	MYT
Latitude Adjustment Wedge for use below 10 degrees and above <i>about</i> 64 degrees latitude	✓	✓	✓
WiSky Wi-Fi Control plugs into the MKS 5000 PCB	✓	✓	✓
Absolute on-axis encoders	✓	Not available.	Not available.
Versa-Plate Spacers	✓	Not available.	Not available.
EGO™ Battery to Paramount Power Adaptor	✓	✓	✓

Optional Software Add Ons and Databases

TheSkyX Professional Edition offers additional software Add Ons and astronomical databases.

- For imaging system's housed inside an automated astronomical dome, consider the *optional TheSkyX Professional Edition Dome Add On* (<http://www.bisque.com/dome>) to automatically keep the dome aligned to, and track with the mount. (The Dome Add On is included with all Paramount ME IIs shipped after January 2015.)
- TheSkyX Professional Edition Database Add On (<http://www.bisque.com/DatabaseAddOn>) offers over 200 GB of astronomical catalogs.

Getting Help

If you have questions about your Paramount, please first carefully review the information in this document. If you still cannot find an answer, please visit the Software Bisque web page to join and sign in (www.bisque.com/newbie). Next, click the Support button or visit www.bisque.com/support and click the **Write a New Post** link on the Paramount ME II Support Forum www.bisque.com/sc/forums/114.aspx, the Paramount MX/MX+ Support Forum www.bisque.com/sc/forums/96.aspx, or the Paramount MYT Support Forum www.bisque.com/sc/forums/122.aspx to ask your question. Software Bisque monitors this forum between 9 a.m. to 5 p.m. Mountain Time Monday-Friday and tries to respond to questions within 3-5 business days (typically faster). Our knowledgeable community members are there to help outside regular office hours.

What You Need to Know

Successful operation of a Paramount requires a solid understanding of many basic astronomy concepts, a familiarity with operating a GEM, as well as an understanding *TheSkyX Professional Edition*.

If you are new to the Paramount, operating a GEM, or just getting into astronomy, please peruse the following section. Based on years of support feedback, even experienced observers often do not understand fundamental concepts as they relate to operating a Paramount.

- What are the differences between right ascension, azimuth and hour angle?
- Why does the meridian matter when operating a GEM?
- What exactly is synchronization?
- What is homing and what does it actually do?
- What is mount parking?
- How does atmospheric refraction affect mount performance?
- Why is polar alignment so important?

In addition to these basic questions, if you have never controlled a robotic GEM with *TheSkyX Professional Edition*, please carefully read the following sections and then use *TheSkyX Professional Edition's* Telescope Simulator feature before setting up, connecting to, and operating the Paramount.

Coordinate Systems

The three most common coordinate systems used when working with equatorial mountings are described below. Making sure you understand the differences between each now can really help troubleshooting issues in the future.

The Horizon Coordinate System

The horizon or “horizontal” coordinate system is used to specify the position of celestial objects relative to the local horizon.

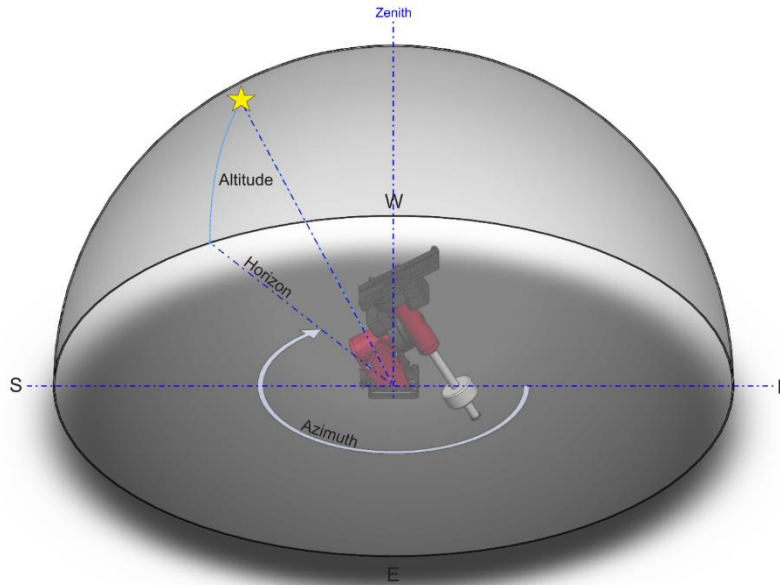

Figure 1: The horizon-based altitude and azimuth coordinate system.

Altitude

The altitude (alt) of an object is expressed as the number of degrees from the horizon (the ground at a far distance) to the object, and is always between minus 90 and plus 90 degrees. Objects that have a negative altitude are below the horizon. For example, the Sun just after sunrise is close to the horizon so it has an altitude of a few degrees or less, and just after sunset its altitude is minus a few degrees degrees.

Azimuth

The azimuth (az) of an object is generally reckoned from North, increasing in the clockwise direction, and ranges from 0 to 359 degrees. North is 0 degrees, east is 90 degrees, south is 180 degrees and west is 270 degrees.

When the Paramount is controlled by *TheSkyX Professional Edition*, attempting to slew the mount below the local horizon is not permitted and will result in an error message.

The Equatorial Coordinate System

The horizon coordinate system is not convenient for specifying the location of celestial objects because the horizon coordinates of stars and other objects are continuously changing with time (due to the rotation of the Earth).

The exception occurs with objects near the north and south celestial poles. These positions are unique since they are near to the axis of rotation of the Earth and therefore move only in small circular paths. Polaris, the North Star, for example, remains at a nearly constant altitude and azimuth. In the equatorial coordinate system, the coordinates of all celestial objects remain fixed* from hour-to-hour, day-to-day and so on.

An object's equatorial coordinates remain the same regardless of from where on Earth the object is viewed. This allows astronomers to create star maps that apply to any place on Earth, or publish the anticipated position of an upcoming comet so that astronomers everywhere know where it is located among the stars.

The equatorial coordinate system used to specify the positions of celestial objects is directly analogous to the latitude-longitude coordinate system used on Earth. In fact, if you were to expand the latitude and longitude grid of the Earth so that it is out beyond all stars, you would have a sphere with identical geometry to the celestial sphere.

We suppose that all stars and deep-sky objects are located on a very large sphere (out beyond all stars). We call this the celestial sphere. For purposes of describing the positions of celestial objects, we consider all stars and deep sky objects to be on the celestial sphere, when actually they are all positioned at varying distances from the Earth.

** Equatorial coordinates change over long periods of time due to precession (wobbling of the Earth). TheSkyX computes this change in stars' position for the current date. Precession, however, does not change the relative positions of objects with respect to one another.*

Right Ascension

The geometry of the right ascension (RA) lines on the celestial sphere is the same as the longitude lines on Earth. Longitude lines divide the Earth into 360 degrees. Right ascension lines divide the celestial sphere into 24 hours, based on one revolution of Earth. Therefore, one hour of right ascension equals 15 degrees (360 divided by 24). See the definition of Local Sidereal Time for additional information on why 24 hours are used for right ascension instead of 360 degrees.

Zero degrees longitude passes through Greenwich, England and is the designated reference line for longitude. What, then, is the reference line for 0 hours right ascension? Astronomers use the *vernal equinox*, the location where the Sun crosses the celestial equator during its apparent annual motion against the background stars, as a "starting point" for right ascension.

The term "right ascension" comes from the fact that when viewed from the equator, all stars rise (or ascend) at right angles to the horizon, so their times of rising are called their times of right ascension.

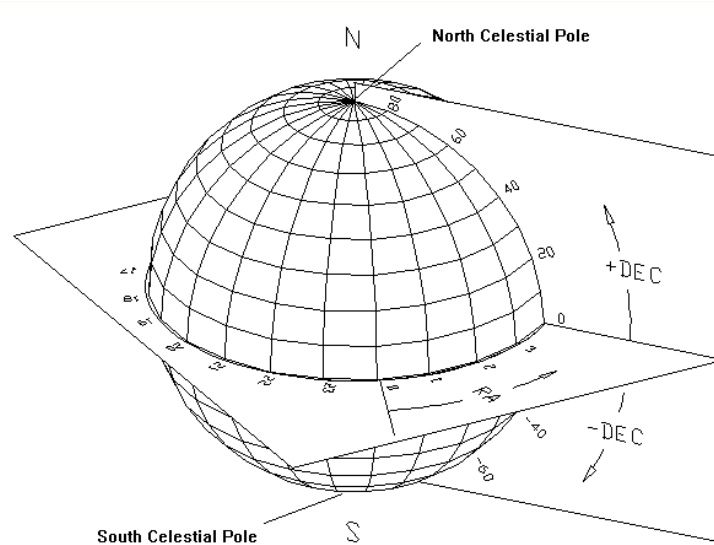

Figure 2: Right ascension and declination relative to the celestial sphere.

Declination

The declination (dec) lines on the celestial sphere are similar to latitude lines on Earth, ranging from -90 degrees to $+90$ degrees. The “declination” of an object is the angle measured from the celestial equator (0 degrees declination) along a meridian line through the object. Polaris, the North Star has a declination of just over 89 degrees so it is very close to the north celestial pole.

Hour Angle

Hour angle (HA) is measured from the meridian westward, along the celestial equator and uses the same units as right ascension (hours, minutes, and seconds). A celestial object on the meridian is located at hour angle 0 . Six hours of time later, the object is located at hour angle $+6$. Twelve hours later, when the object rises, its hour angle is -6 h.

Hour angle can be used to describe a telescope’s mechanical orientation with respect to a horizon-based hemisphere. For Paramount mounts with AutoHoming™, when the mount finds home, the home position is a fixed, mechanical mount orientation. In the northern hemisphere, when homing is successful, the mount *always* points to hour angle 2 and declination 0 .

Smaller hour angles equate to positions of optimal observing, so your telescope will probably spend a great deal of the time pointing to and tracking objects near hour angle zero (near the meridian, that is).

Note that *TheSkyX Professional Edition* can be used to configure the Paramount’s “flip hour angle” (page 127) in order to maximize the length of time an object can be tracked past the meridian.

Local Sidereal Time

Local sidereal time (LST) is always equal to the instantaneous right ascension of the local meridian. When you know the LST, you can look at star maps and determine which objects are near the meridian (those

with a right ascension close to the LST). For example, if the LST is 6:10:00, this means that stars with a right ascension of about 6 hours are visible along the meridian.

If everyone reckoned time based on the Sun crossing the meridian, then each longitude on earth would have a different time of day. That means noon, or the time the Sun crosses the meridian, would come a few minutes earlier for someone living 60 miles to the east. Only those people living at the same longitude would share a common time.

In the late 1800's time zones were established to minimize the problem of having different time in populous regions. The time within these zones is called *zone time*. Zone time places all locations on Earth into various time zones. By definition, time zone zero is at zero degrees longitude, and the time zone increases by one hour every 15 degrees longitude moving east, or decreases by one hour moving west.

The Paramount relies on *TheSkyX Professional Edition* uses the correct time zone for your observing site. When *TheSkyX Professional Edition's* time zone is not correct, the position of the telescope cross hairs will be offset by the time zone hour error when viewing horizon-based Sky Charts.

Atmospheric Refraction

The effects of atmospheric refraction on the position of celestial objects, as well as its effect on the sidereal tracking rate, are often overlooked or even ignored by many amateur astronomers.

The refraction nuisance (and other system errors like tube flexure) means the "sidereal tracking rate" is simply not good enough to precisely track objects. Refraction also displaces the position of the celestial pole and makes precise polar alignment more difficult.

Some other interesting and significant facts about how refraction affects an object's apparent position include:

- For a sea-level site, the refraction at 45 degrees zenith distance (ZD) is about 60 arcseconds (one arcminute).
- Except low down in the sky, the refraction goes roughly as the tangent to ZD, so at ZD = 70 degrees, or, at 20 degrees above the horizon, it is up to 165 arcseconds. (It reaches *1800 arcseconds*, or 0.5 degrees at the horizon.)
- Refraction is proportional to pressure, so at high-altitude sites the refraction comes down significantly. For example, at Mauna Kea, 4,205 meters above sea level, the refraction is about 60 percent of the sea level amount.
- Refraction is roughly inversely proportional to absolute temperature, so at -5C the refraction is about 10 percent more than at 20C.
- Humidity has little effect in the optical, though it matters a lot at radio wavelengths.
- The color of the observed object matters, blue being refracted a few arcseconds more than red at ZD 70.

When you use your Paramount to take long, unguided exposures at modest or longer focal lengths, refraction becomes an important source of tracking error that is not taken into account in the standard sidereal tracking rate.

TPoint can be employed to take care of the atmospheric refraction details for you.

- TPoint’s Super Model feature and Polar Alignment Report automatically determines the position of the refracted pole and give recommendations on how to proceed, including how much to rotate the altitude and azimuth knobs when adjustment is necessary.
- It accounts for and applies refraction when acquiring telescope calibration data as well as corrects the telescope’s position when the mount is slewed.
- TPoint’s ProTrack™ feature can be used to apply tracking corrections to the mount based on the point calibration data (page 174).

Polar Alignment Basics



For optimal performance, the equatorial axis of a GEM must be aligned to the *refracted pole* to within 100 arcseconds.

If the mount’s equatorial axis is not “closely” aligned with the celestial pole...

- Stars will drift in of the field of view, mostly in declination; quickly when polar alignment is particularly poor.
- When you tell *TheSkyX Professional Edition* where the mount is pointing, through a process called “synchronization” (page 26), the synchronization results will be incorrect, or “skewed” by the amount of the polar alignment error. For example, if the polar axis is ten degrees “low” in altitude, then the resulting synchronization positions computed by *TheSkyX Professional Edition* will be off by this same amount in declination. The result is that the mount will not point with any accuracy or repeatability.
- The mount’s “TPoint unassisted pointing accuracy” will be disappointing, especially when the OTA switches sides of the pier.

These symptoms may make you frustrated with the performance of your Paramount and leave you wondering, “What am I doing wrong?” Mastering the polar alignment techniques described below (or using your preferred polar alignment technique) is crucial to achieve optimal mount performance.

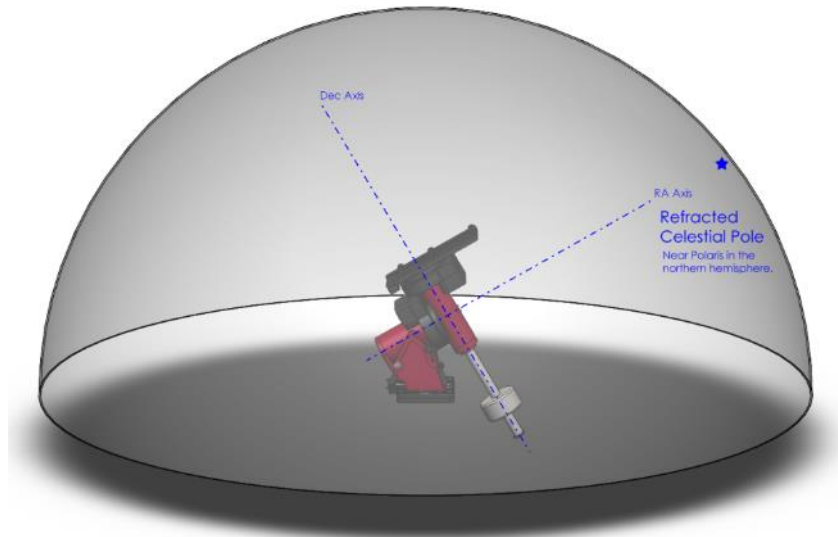

Figure 3: Paramount aligned with the refracted celestial pole in the northern hemisphere.

Software Bisque recommends the following polar alignment methods to ensure efficient and optimal polar alignment.

- Step 1 Use the “Rough Polar Alignment Method” (page 116) to align the mount’s polar axis to within 10-15 arcminutes of the pole, even during daylight.
- Step 2 If the pole is visible, and you have a polar alignment scope (page 119), use it to roughly align the mount to the celestial pole.

-Or-

Use the TPoint Add Ons’ **Accurate Polar Alignment** command, or the *TPoint Add On’s* Polar Alignment Report to determine how much the altitude adjuster (page 95) and azimuth adjuster knobs (page 95) need to be rotated so that both axes are aligned to the refracted pole.

See “How to Polar Align” on page 115 for the best ways to achieve optimal polar alignment.

Homing



Mount synchronization is one of the least understood and most confusing processes for new Paramount users; understanding exactly what homing a Paramount does is a very close second. Please carefully read the following to avoid falling into the “my mount is not homing to the correct position” trap.

Finding the home position, or “homing” the Paramount is an automated mount initialization process. When the Paramount control system receives the “find home position command”, the mount’s right ascension *and* declination axes are slewed to an **absolute, mechanically fixed** orientation.

Homing *must be performed every time* the Paramount is powered on so that the control system can establish the mount's position.

Once the mount is successfully homed, and the previous session's pointing calibration is applied, the telescope will know its orientation and have close to the same pointing accuracy as the last observing session.



- The home position is located at hour angle 2 and 0 degrees declination. The home position is a *fixed, mechanical orientation* and *cannot change*; it is defined by the *physical position* of the gears relative to fixed internal homing sensors. See “Physically Marking the Home Position” on page 25 for a simple procedure to demonstrate the mount's absolute home position.
- If the mount is not physically pointing to approximately hour angle 2 and 0 degrees declination after finding home, then either the Versa-Plate is mounted incorrectly, the mount's polar axis is not oriented north-south.
- If, after homing is complete, the coordinates of the telescope cross hairs displayed by *TheSkyX Professional Edition* indicate that the mount is pointing anywhere other than the home position, then either *TheSkyX Professional Edition's* location, date, time or time zone is not correct, or the mount has been synchronized incorrectly. See “Synchronization” on page 26 for more information.



The Paramount cannot slew and will not track at the sidereal rate until after the mount is successfully homed.

When a ***Find Home*** command is issued from the hand controller (by double-tapping the button on the end of the joystick handle, see page 111 for details) or from *TheSkyX Professional Edition* (page 124), the mount slews to the home position and zeros the control system's “position registers”.

Subsequent observing sessions use *TheSkyX Professional Edition's* local sidereal time to determine the mount's equatorial coordinates. Make sure the computer's clock maintains accurate time (page 30).

Homing provides the following benefits:

- Once a mount is aligned with the celestial pole and homed, repeatable and accurate pointing from night to night can be achieved using *TheSkyX Professional Edition* and the *TPoint Add On*.
- After homing, the mount “knows” its orientation and therefore cannot be slewed into the pier (see “Software Slew Limits” on page 167).
- The control system's periodic error correction (PEC) uses this information to calibrate the control system's internal PEC table with the orientation of the worm gear.
- The mount's orientation can be restored after power outages or other communication malfunctions.

- The home position can be used to align the polar axis to the celestial pole (see “Rough Polar Alignment Method” on page 116).

Labeling the Home Position on the Sky Chart

Synchronizing the mount (page 26) on the wrong star or configuring *TheSkyX Professional Edition* to use the wrong location, date, time or time zone for your location means the Paramount will be “lost in space”. The telescope cross hairs will appear in the “wrong” place on the Sky Chart and the mount does not slew to the correct coordinates when commanded to do so.

If the coordinates of the telescope cross hairs do not match the actual physical orientation of the Paramount, or the mount does not slew to the correct coordinates, you will be scratching your head wondering what is wrong. The next step is to post a support question asking, “Why is my mount pointing to the wrong coordinates?”

For this reason, Software Bisque strongly recommends creating a label that shows the location of the mount’s *absolute home position* (page 157) directly on the Sky Chart to provide a constant visual reminder of where the telescope cross hairs *must be* after finding home.

If, after homing the mount, the telescope cross hairs do not end up very near hour angle 2 and declination 0 (or hour angle -2.0 , declination 0 in the southern hemisphere), either *TheSkyX Professional Edition*’s site information is wrong or the mount has been synchronized on the wrong star.

Remember, the *absolute home position* of the Paramount *cannot change*. So, if the mount’s *relative home position* is wrong (or the telescope cross hairs do not appear in the correct location on the Sky Chart), please double check the synchronization (page 26) and *TheSkyX Professional Edition*’s location, date and time settings for your location before submitting a support request.

To Label the Home Position in Software

The following procedure assumes this is a first time mount synchronization.

1. From *TheSkyX Professional Edition*, choose the **Location** command from the **Input** menu and make sure the settings on the **Custom** tab match your observing site.
2. Choose the **Verify TheSkyX Time** command from the **Tools** menu to make sure your computer’s time matches an independent time source.
3. Choose the **Connect** command from the **Telescope** menu. The mount **Status** text will show **Not Homed**.
4. Choose the **Find Home** command from the **Start Up** pop-up menu on the **Telescope** window. The mount will slew to the home position.
5. Choose the **Turn Tracking Off** command from the **Tools** pop-up menu on the **Telescope** window. Turn tracking off to pin the mount to this position.
6. Choose the **TPoint Add On** command from the **Telescope** menu.

7. Then turn off the **Apply Pointing Corrections** checkbox on the **Setup** tab and click **Close**. TPoint will change the position of the telescope cross hairs based on the current model and we want the label to show the “unmodeled” cross hair position.
8. Click on the center of the telescope cross hair and note the exact altitude and azimuth of this position. This is the horizon-based coordinate of the home position.
9. Choose the **My Chart Elements** command from the **Input** menu.
10. Click the **Add Object** button (the upper-left most button on the **Manage** tab), then click the **Add and Edit** button to add an object to the Sky Chart.
11. On the **Add/Edit Chart Element** window, turn on the **Horizon** radio button, then enter the azimuth (**Azm**) and altitude (**Alt**) of the telescope cross hair. In the **Label** text box, enter the text **Absolute Home Position** and then click **OK**.

The Sky Chart now shows a label at the absolute home position of the mount. To double-check the accuracy of this position, choose the **Find Home** command. Note that, when compared to the absolute home position, the position of the telescope cross hairs on the Sky Chart will also be affected by the following:

- Synchronizing the mount on a star introduces small pointing errors.
- A TPoint pointing model will change the position of the telescope cross hairs based on the pointing calibration data.

The above two items necessarily introduce a small offset between the mount’s absolute home position and the position of the telescope cross hairs after finding home (once the mount has been synchronized and a TPoint model is established).

Physically Marking the Home Position

If, after finding the home position, the cross hairs that are displayed on the Sky Chart are at the wrong coordinates, one or more of the following is probably true:

- The mount is not aligned to the celestial pole. (Believe it or not, Software Bisque has had several support cases claiming that the mount could not point the telescope correctly, only to discover the Paramount’s polar axis was mounted in the wrong direction; for example, the polar axis was pointing south in the northern hemisphere, in other words, 180 degrees off.)
- The optical tube assembly is mounted “backwards” on the Versa-Plate.
- In TheSkyX Professional Edition’s location, date, time, time zone or Daylight Saving Time settings are wrong for your observing site.
- The wrong star was centered in the eyepiece when the mount was synchronized. Improper synchronization results in the telescope cross hairs to be displayed at the wrong spot on the Sky Chart. And this error is particularly apparent after the mount is homed.

Many come to the incorrect conclusion when the telescope cross hairs on the Sky Chart are wrong, there must be something wrong with the homing process. Homing is generally very reliable and rarely fails. The

procedure below demonstrates that, after homing, the Paramount is *always in the same mechanical position*.

1. Home the mount.
2. On each axis, place a piece of masking tape over the rotating portion and cut the tape between the rotating parts of the mount. The “vertical” edges of the tape mark the home position in that axis.
3. Use the joystick (or TheSkyX Professional Edition) to slew the mount to any orientation.
4. Double-tap the joystick to find home again.



Figure 4: Marking the Paramount’s home position.

The Paramount will dutifully return to the identical position in each axis.

This “homing repeatability test” will hopefully provide confidence that, after finding home, the mount is always pointing to hour angle 2 and declination 0 (in the northern hemisphere), and will help narrow down the *actual causes* of pointing errors (most commonly, an invalid synchronization, incorrect settings in TheSkyX Professional Edition, or poor polar alignment).

Synchronization

Synchronizing (or “syncing”) the Paramount tells the mount, “You are here!” Synchronization involves centering a known star in the eyepiece, identifying this star in *TheSkyX Professional Edition* then choosing the **Synchronize** command from the **Start Up** pop-up menu on the **Telescope** window.

When the Paramount is synchronized to a star, *TheSkyX Professional Edition* uses the equatorial coordinates of the star to initialize the control system at this position.

In theory, after a *permanently mounted* Paramount is aligned with the celestial pole (page 21), it need be synchronized only once. In practice, the mount will have to be synchronized:

- Each time the mount is setup for portable use.
- When the mount's polar alignment is changed.
- When the optical tube assembly (OTA) is changed.

Synchronization is essential to mount initialization. If the mount is not synchronized correctly, the actual orientation the telescope will not match the simulated telescope's position on the Sky Chart. And, when commanded to slew from *TheSkyX Professional Edition*, the telescope will end up pointing at the wrong place in the sky.

Best Synchronization Practices

- **Do not synchronize on stars near the celestial pole** – The celestial pole represents a point of “singularity” on the celestial sphere. As a best practice, do not synchronize on Polaris (in the northern hemisphere) and **avoid stars above 80 degrees declination or so**.
- **Use brighter, easily identifiable stars** – Fainter stars can be hard to identify, making synchronization more difficult.

Step by Step Synchronization

Carefully follow the procedure below to ensure that synchronization is performed correctly. If you make a mistake and point the telescope at the wrong star, for example, see “Starting Synchronization Over” on page 29 to restore the default settings and try again.

1. Set the computer's clock accurately. Accurate time is crucial for consistent, accurate pointing and synchronization. Consider using an Internet time server or a GPS-based clock to regularly update your computer's clock and keep it accurate. See “The Local Celestial Meridian” on page 30 for more information.
2. Choose the **Location** command from the Input menu to set the observing site's latitude, longitude, time zone and Daylight Saving option if necessary.



Consider using a GPS to also obtain your site's latitude and longitude. Make sure the time zone and daylight saving options are correct for your location (a GPS does not supply this information).

- Errors in latitude “appear” to TPoint as a vertical misalignment in the polar axis, and will pollute synchronization (and the TPoint model, if one is in place).
 - If your time zone is off by one hour or more, then pointing will be off by the same amount.
 - If the wrong Daylight Saving Option is selected, then time will be off by an hour (or more) and the mount will not slew to the correct position.
3. Choose the **Connect** command from the **Telescope** menu.
 4. Choose the **Find Home** command from the **Start Up** pop-up menu on the **Telescope** window.

5. Locate an easily identifiable, bright star to use for synchronization.

Partial clouds or twilight can make this task more difficult than it might seem. The Paramount can be synchronized to virtually any position on the celestial sphere on the east or west side of the meridian (See “

Best Synchronization Practice” on page 27).

6. Center the bright star in the eyepiece, photo or video display using the joystick on the hand controller or *TheSkyX Professional Edition's Motion Controls* on the **Telescope** window.
7. From *TheSkyX Professional Edition*, enter the name of the bright star in the **Search For** text box and click the **Find** button on the **Telescope** window to identify the star. Or, click on the star if it is visible on the Sky Chart.
8. Choose the **Synchronize** command on the **Start Up** pop-up menu in **Telescope** tab. When the **Telescope Synchronization** window appears, click the **Sync** button.

The mount is now synchronized on the bright star.

Session to Session Pointing Repeatability

In subsequent observing sessions, *TheSkyX Professional Edition* computes the current equatorial and horizon coordinates of the telescope using the stored hour angle and declination of the mount and the local sidereal time. In fact, the Paramount's pointing accuracy should be virtually identical from session to session.

Please verify the *repeatability* of the Paramount pointing before proceeding (this test assumes that the mount's polar axis is aligned with the celestial pole):

1. Turn the mount off.
2. Turn the mount on (this terminates communication between *TheSkyX Professional Edition* and the *Paramount*).
3. Home the mount.
4. From *TheSkyX Professional Edition*, choose the **Connect** command from the **Telescope** menu. The telescope cross hairs appear at the *relative home position* (see page 157 for an explanation of the difference between the *absolute* and *relative* home position).
5. Slew the mount to the star you just synced on. The mount should slew back to this star; that is, it should return to the same position in the eyepiece, video or CCD detector. In practice, there may be small pointing errors that are introduced by mirror flop, or slight differences in time, so the star may not be in *exactly* the same position, but it should be very close.

Note that during the process of polar alignment, you will be required to synchronize the mount several times (each time the mount is adjusted to a new altitude and/or azimuth). For permanent installations, once the mount is sufficiently aligned with the celestial pole, it should not have to be synchronized again unless the optical tube assembly or the telescope's physical mounting changes.

Portable setups must synchronize the mount each session, or, if a TPoint pointing model will be used, a Portable Recalibration, as described in the TPoint Add On User Guide, must be performed first.

Making Sure Synchronization Is Correct

The Sky Chart provides graphical feedback to help verify the mount is synchronized correctly and identifies the regions near the meridian that have unique behavior when tracking or slewing. While *TheSkyX Professional Edition* is connected to the Paramount, two regions are drawn near the meridian. If the regions are centered on the meridian, then the synchronization is most likely correct.

Purple Region

When the optical tube assembly is on the east side of the mount (pointing to the west), the purple region (that is, the region on the east side of the meridian) indicates the area where the mount can be slewed beyond the meridian without flipping sides. If the OTA is on the east side, and you attempt to slew beyond this region, the mount automatically flips sides.

Red Region

When the optical tube assembly is on the west side of the mount, the red region indicates how far past the meridian the mount can track before encountering a software or hardware limit. If the OTA remains on the west side and the mount tracks to the tracking limit, then tracking is turned off. Note that the Paramount will *not* automatically slew the OTA to the opposite side of the pier in this situation. The red region also indicates the area where, when the OTA is on west side, the mount can be slewed beyond the meridian, without requiring the OTA to slew to the opposite side of the pier.

Synchronization Checklist

- Make sure that the computer's time is accurate, and that *TheSkyX Professional Edition* is configured to use the computer's clock.
- Verify that synchronization is performed using the star listed in *TheSkyX Professional Edition's* Object Information Report. When clicking the Sky Chart to identify an object, the Object Information Report can list other objects that are "near" the mouse click position.
- In general, avoid synchronizing on a star that is located near the meridian.
- Avoid synchronizing on stars above 80 degrees declination or so.

Starting Synchronization Over

If you are ever unsure about synchronization, you can start over by:

1. Choose the **Connect** command from the **Telescope** menu.
2. Choose the **TPoint Add On** command from the **Telescope** menu.
3. Choose the **New** command from the **TPoint Add On Settings** pop-up menu on the **Setup** tab and click **Yes** when asked to clear the pointing data and pointing model.

The Local Celestial Meridian

The local celestial meridian is a great circle on the celestial sphere that runs from the zenith directly overhead to a point due South on the horizon, continuing around to the nadir (directly below) and back up to the zenith. This line divides the celestial sphere into east and west hemispheres.

From *TheSkyX Professional Edition*, expand **Reference Lines and Photos** in the **Chart Elements** window and turn on the **Meridian** checkbox.

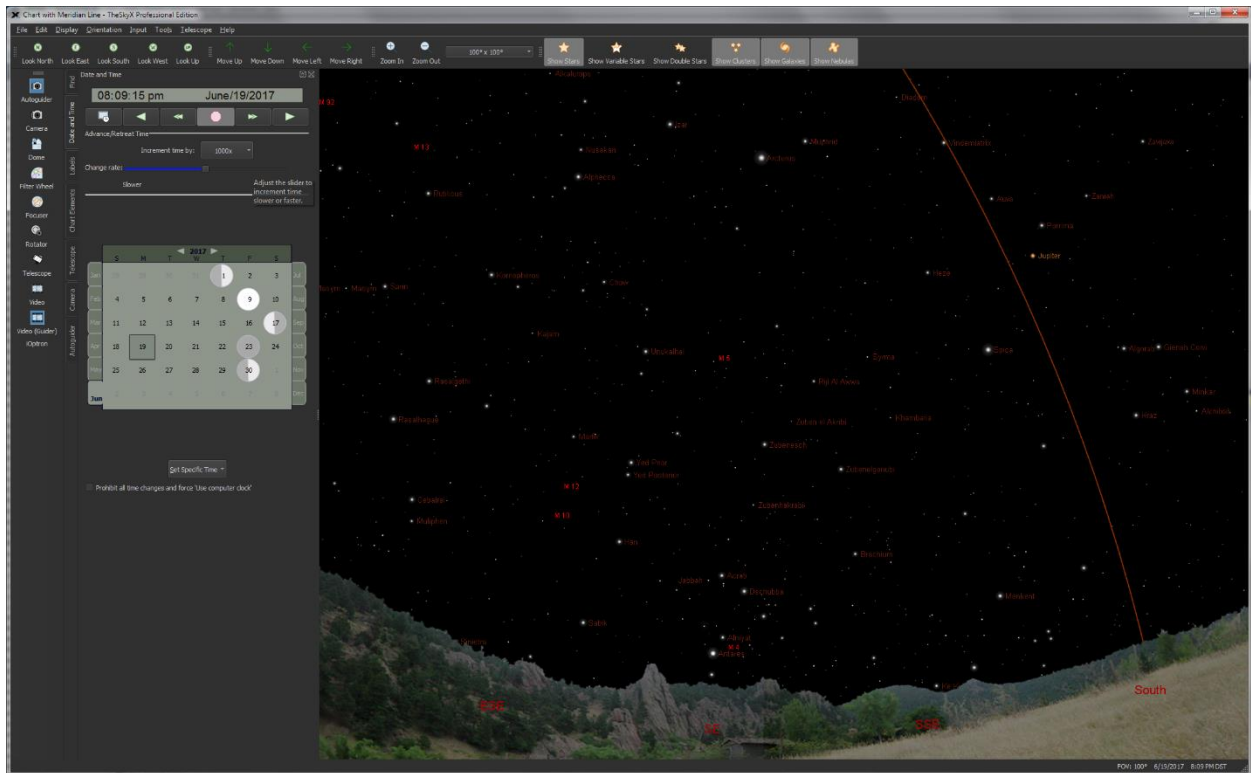

Figure 5: *TheSkyX Professional Edition* with the meridian reference line turned on.

The arcing line in Figure 5 represents the local celestial meridian. When the Paramount is at the home position, the telescope is pointing to the west side of the meridian, near hour angle 2 and declination 0 in the northern hemisphere. (Or, hour angle -2.0 and declination 0 in the southern hemisphere).

If the optical tube assembly is not pointing to the home position, or if the telescope cross hairs in the *TheSkyX Professional Edition* indicate that the home position is anywhere else (by more than a few arcminutes or so), then one or more is the case:

- *TheSkyX Professional Edition* is not configured correctly for your location.
- The Versa-Plate is mounted in the wide configuration (page 66).
- The Versa-Plate is mounted 180 degrees off.

Before continuing, make sure that *TheSkyX Professional Edition's* location, date, time, time zone, and Daylight Saving Option are correct. Also, make sure the Versa-Plate is mounted in the correct orientation before proceeding.

Maintaining Accurate Time

The Paramount can provide very accurate all sky pointing during a single session without an accurate time base (that is, if the computer's clock is accurate to one or two minutes or so). However, *TheSkyX Professional Edition* must make decisions on how to slew to various positions in the sky based on the local time. For example, an object that is on the east of the meridian may require the telescope be slewed to west side of the pier and vice versa. So, maintaining accurate time is important.



Always perform "reality check" by comparing the coordinates of objects in TheSkyX Professional Edition to objects in the night sky. If TheSkyX Professional Edition's location or time is not accurate, the coordinates reported by TheSkyX Professional Edition will not be accurate.

Choose the ***Verify TheSkyX Time*** command on the ***Tools*** menu to compare the computer's date, time and time zone settings with a web-based time source.

Initializing the Paramount requires a very accurate time base. *TheSkyX Professional Edition* uses the computer's clock to compute the local sidereal time (LST). When a connection is established between *TheSkyX Professional Edition* and the "homed" Paramount, the LST is used to re-establish the synchronization between the Paramount's "electronic setting circles" and the celestial sphere to within a few arcseconds. If the computer's time is accurate, you can just power-up the mount, home, and then start imaging each night.

Setting the Computer's Clock

The best method to accurately set your computer's clock is with "time server" software. Remember, each second of error in time translates to *fifteen arcseconds error in angular distance near the celestial equator*. So, telescope pointing will degrade if time is not accurately maintained from night to night.

Inaccurate time causes the mount to slew to objects ahead or behind objects in right ascension by a consistent offset. Software that periodically resets your computer's clock using an accurate time base solves this problem.

Many applications maintain accurate time and most operating systems can be configured to update the computer's clock automatically. Windows users might consider Dimension 4 from Thinking Man Software. Search the web for "time server software" to locate alternatives.

Parking the Paramount

Parking is a command that can be issued to the Paramount from *TheSkyX Professional Edition* and performs the following operations:

1. After confirmation by the user, the mount is automatically slewed to a user-defined altitude and azimuth coordinate, called the *park position*.
2. Once the park position is reached, the Paramount's tracking is immediately turned off.
3. Communication between *TheSkyX Professional Edition* and the mount is terminated.

Note that the park position is not used to initialize the mount.

Parking from TheSkyX Professional Edition

From *TheSkyX Professional Edition*, connect to the mount, and then choose the **Park** command from the **Shut Down** pop-up menu on the **Telescope** window. You will be asked to confirm that you want to slew the mount to the park position and park the mount.

Defining the Park Position

Before parking the Paramount, you need to define the park position. This is the position that the mount will slew to when the Park command is issued from *TheSkyX Professional Edition*. Please carefully read "Park Position Rules" below.

With a telescope link established, slew the telescope to the desired park position. From *TheSkyX Professional Edition*, choose the **Set Park Position** command from the **Shut Down** pop-up menu on the **Telescope** window. The park position needs to be set once; the coordinates of the mount (in altitude/azimuth) are automatically saved for future parks.

Software Bisque recommends that, if possible, the telescope be parked as close to the home position as practical. Since the Paramount must be homed at power up, the time required to find the home position is reduced when the park position is near the home position.

Park Position Rules

- The Paramount must be correctly synchronized *before* the mount is parked and before the park position can be defined. Otherwise, the mount will not return to the correct park position.
- When defining the park position near the meridian, make sure that the OTA is on the opposite side of the meridian as the equatorial coordinate of the park position. In other words, never define the park position when the counterweight shaft is "above" horizontal.

Here is an example of a situation that will cause unexpected parking behavior. Suppose you want your telescope to always park in the same orientation "near" the meridian, with the OTA on the east side (and the counterweights on the west side) of the mount. So, you slew the mount to a location near the meridian that also happens to be on the east side of the meridian, and then define the park position.

Since the Paramount allows the OTA to slew *past* the meridian (two hours maximum for the Paramount ME II and 2.5 hours for the Paramount MX and Paramount MX+) before flipping sides, you have now defined a park position that will cause the mount to slew to a different orientation than when the park position was defined. In this example, when you park the mount, the control

system will still park the telescope near the meridian, but with the OTA on the west side (and the counterweights on the east side) of the mount.

- For mounts in the northern hemisphere, do not define the park position from due west to due east (through north), and below the *altitude* of the celestial pole. For mounts in the southern hemisphere, do not define the park position from due east to due west (through south) and below the *altitude* of the celestial pole.

Audible Control System Feedback

Each time the mount is turned on the control system performs both an electronics and servomotor initialization procedure, and emits different sounds based on the status of the initialization. A short whistle is emitted immediately after the power switch is turned on and indicates successful initialization of the control system electronics; two successive beeps (usually occurring a few seconds or so apart) indicate servomotor initialization success. The three LEDs on the Electronics Box, labeled TCS, RA, and Dec, provide additional visual feedback of mount initialization. See “Electronics Box Components” on page 80 for details.

The initialization procedure is terminated if the joystick button is pressed and held down when the mount is turned on, or the joystick is moved from the center position before the servomotor initialization is complete. In this situation, the mount emits a *single* beep. When initialization is interrupted for any reason, the mount will not slew or track. Before attempting to slew or home the mount, make sure the joystick is in the center position, power the mount off then on, and then wait for the two beeps that indicate the mount is ready for normal operation.

The table below describes the different sounds that the mount can emit, when the sound occurs, and explains what the sound means. Visit the [Videos and Audio Clips](#) page on the Software Bisque web site to listen to recordings of these sounds. To get there, navigate to www.bisque.com, click the **Downloads** link, then click the **Video and Audio Clips** link under **Browse Downloads** in the left column of the **Downloads** page. The audible feedback recordings are listed on the right of the web page.

Sound	Occurs	Description
Short whistle	Immediately after turning the power on.	The sound indicates the control system is operational.
Two beeps from about two seconds apart	Shortly after mount is turned on.	Indicates that the control system has successfully located the DC servomotor’s “index” position in right ascension and declination. The mount is ready for normal operation.  Exactly <i>when</i> the two beeps occur will be different for each mount and will vary depending on the mount's current mechanical orientation. The beeps may even occur simultaneously so that only a single beep is audible.

Sound	Occurs	Description
		<p>If the LEDs on the Electronics Box are illuminated, and the mount homes, the control system is functioning normally.</p>
Single beep	When the servomotor initialization is interrupted, shortly after mount is powered on.	<p>Servomotor initialization can be interrupted by the following actions.</p> <ul style="list-style-type: none"> • Pressing and holding the joystick button down and turning on the mount. • Moving the joystick from its center position before the servomotors are initialized. • Attempting to slew or home the mount from <i>TheSkyX Professional Edition</i> before servomotor initialization. For normal initialization, simply turn on the mount and wait for the two successive beeps, without attempting to control the mount via joystick or <i>TheSkyX Professional Edition</i>. • One or both of the Three Position Switches is in the Lock position (page 74).
Ba-dink (lower pitch), ba-dink (higher pitch)	Shortly after the mount has slewed to the home position in each axis.	Indicates that mount has successfully located the home position (page 21).
Continuous, successive, high-pitched beeps.	May occur when attempting to slew the mount.	<p>This sound indicates a control system error condition if the mount cannot slew. “Something” is preventing the servomotors from rotating, so the mount cannot slew or track normally.</p> <p>Typical causes include:</p> <ul style="list-style-type: none"> • The mount encountered a fixed object while slewing. For example, the counterweight shaft has run into a step stool that has been placed next to the pier. • Payload is significantly out of balance and exceeds the maximum torque output of the motor. Make sure payload is balanced before proceeding. • Increased drive train torque demands during cold temperature operation can prevent slews.

Sound	Occurs	Description
Single “click” or “tic” sound	During communication with <i>TheSkyX Professional Edition</i> .	<p>The Paramount will emit a single “click” (or “tic”) when serial communications between the mount and <i>TheSkyX Professional Edition</i> are interrupted. Interruption can occur, for example, when a camera is downloading an image, or during other processor intensive operations.</p> <p>Notes:</p> <ul style="list-style-type: none"> • The clicking noise is normal and expected behavior. • The clicking noise is not indicative of any problems with the mount. • Audible feedback cannot be disabled.
Variable-pitched high-frequency hum	After motor initialization and whenever the mount is powered on and tracking.	<p>When the Paramount is turned on and initialized, the servomotors emit an audible, variable-pitched “humming” sound.</p> <p>This sound is the result of the control system checking and adjusting the position of the servo— about 3,333 Hz, and is normal. This sound serves as the audible “heartbeat” of the mount, and means that the electronics are powered and functioning normally.</p>

Visual Control System Feedback

The three LEDs on the Electronics Box are illuminated based on the status of the control system. See “Electronics Box Components” on page 80 for details.

Through the Mount Cabling

Digital imagers are familiar with the cabling “madness” that occurs when a myriad of devices, including cameras, focusers, filter wheels, focusers, rotators, etc. are connected to the telescope. The Paramount mount’s standard through the mount cabling, and through the mount cabling conduits can be used to help tame cabling chaos.



The Paramount through the mount cable conduits are intended to house cables that carry *low voltage* and relatively *low current* direct current (DC) power, only.

- Software Bisque recommends installing through the mount cables that carry a maximum of +12V DC, 5.0A (60W max).
- ***Never install through the mount cabling that carries an alternating current (AC) power source; for example, +120V or greater at any amperage.***



Always keep fingers clear from the cable conduit access hole!

- While the declination axis rotates during mount slews, an internal shaft in the declination assembly is also being rotated by a very high torque servomotor.
- When the declination axis is being balanced (page 74), the internal shaft can rotate freely and may do so with a high angular velocity when the mount's payload is even slightly out of balance.

In both cases, the rotating internal shaft creates a potentially dangerous pinch point with the outer declination axis assembly that can cut, crush or sever fingers.

Always keep fingers clear during mount slews and use extreme caution when routing cables through the mount, or aligning the declination shaft's "through-hole" during polar scope alignment.

The Paramount allows custom cables to be passed through the mount, entering at the cable conduit through the right ascension and declination axis up to the top of the declination axis and out to the Instrument Panel. Routing cables through the mount has many advantages, particularly during remote operation.

Most imaging systems have numerous cables draped from somewhere near the telescope to the observatory floor. These cables are prone to snag "something" as the telescope slews from one part of the sky to another and often causes problems that require human intervention. Running the cables through the mount all but eliminates these and many other issues.

Routing Cables through the Paramount MX and Paramount MX+

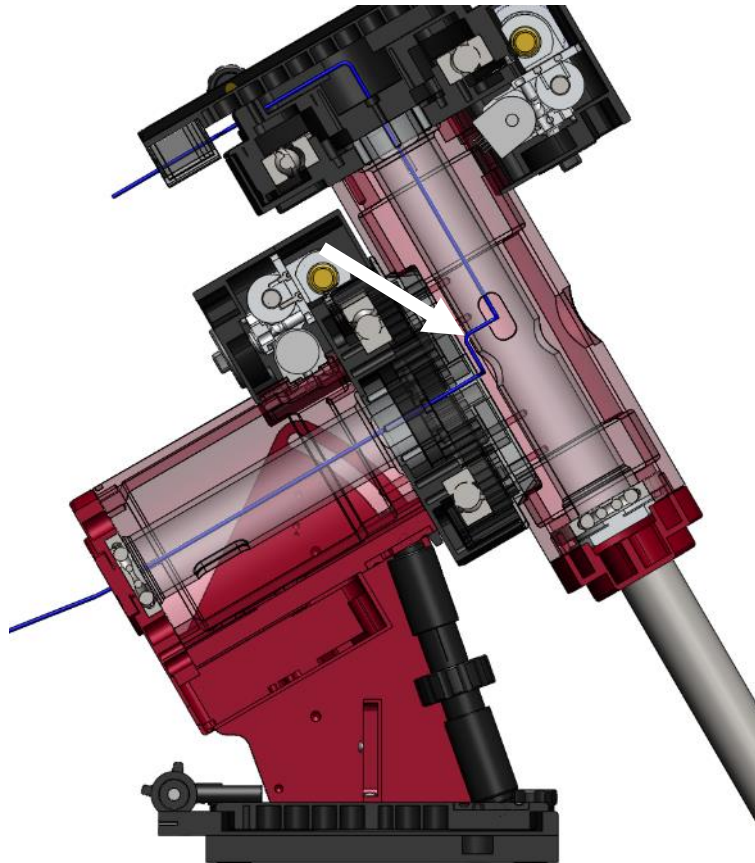

Figure 6: Paramount MX cross section showing path of cable through the mount.

1. Make sure the additional cable is long enough to go from the Instrument Panel (or from a device mounted on the OTA), through the mount and to its destination, then add an additional eight to 10 inches to accommodate a loop in the declination axis (described below).
2. Remove the cable conduit access cover (page 90).
3. Place the declination axis' Three Position Switch in the balance position.
4. Looking down the polar axis through the declination cable conduit access hole, rotate the declination axis from hard stop to hard stop. Doing so reveals two sets of access holes machined into the internal shaft. When aligned with the polar axis, the two larger holes allow light to pass through the mount for polar scope alignment. The two smaller holes (slightly further "up" the shaft) provide a separate passage for the through the mount cabling. Your goal is to snake the cable through one of the two smaller holes (see green arrow in Figure 6).
5. Rotate the declination axis until the unoccupied hole in the internal declination shaft is aligned with the right ascension axis.
6. Loop a 15-inch cable tie the "wrong way" (so the cable tie can be easily removed later) around the end of the cable.



Figure 7: A 15-inch cable tie looped around the cable.

7. Insert the cable tie into the RA Cable Conduit until the end is visible through the cable conduit access cover. The cable tie (and cable) *must be threaded through the outside of the internal shaft* and cannot pass directly through the lower access holes. Rotate the cable tie so that its natural bend forces the tie toward the outside of the shaft. Use a pair of needle-nose pliers to grab the end of the tie then pull the cable all the way through the right ascension axis.
8. Remove the cable tie and feed the end of the cable up the declination shaft, through the upper access hole until it appears at the top of the declination axis.
9. Run the top end of the cable through the access shaft that is machined into the top of the declination axis and the Versa-Plate, out to the left side of the Instrument Panel (page 68).
10. Once the cable has been passed all the way through the mount, make an 8-inch loop in the cable and carefully tuck this loop inside the outer shaft of the declination assembly to allow the declination axis to rotate completely without any interference from the cable itself (see Figure 8). Rotating the declination axis from hard stop to hard stop more or less does the work for you, but allowing additional slack in the cable is recommended.

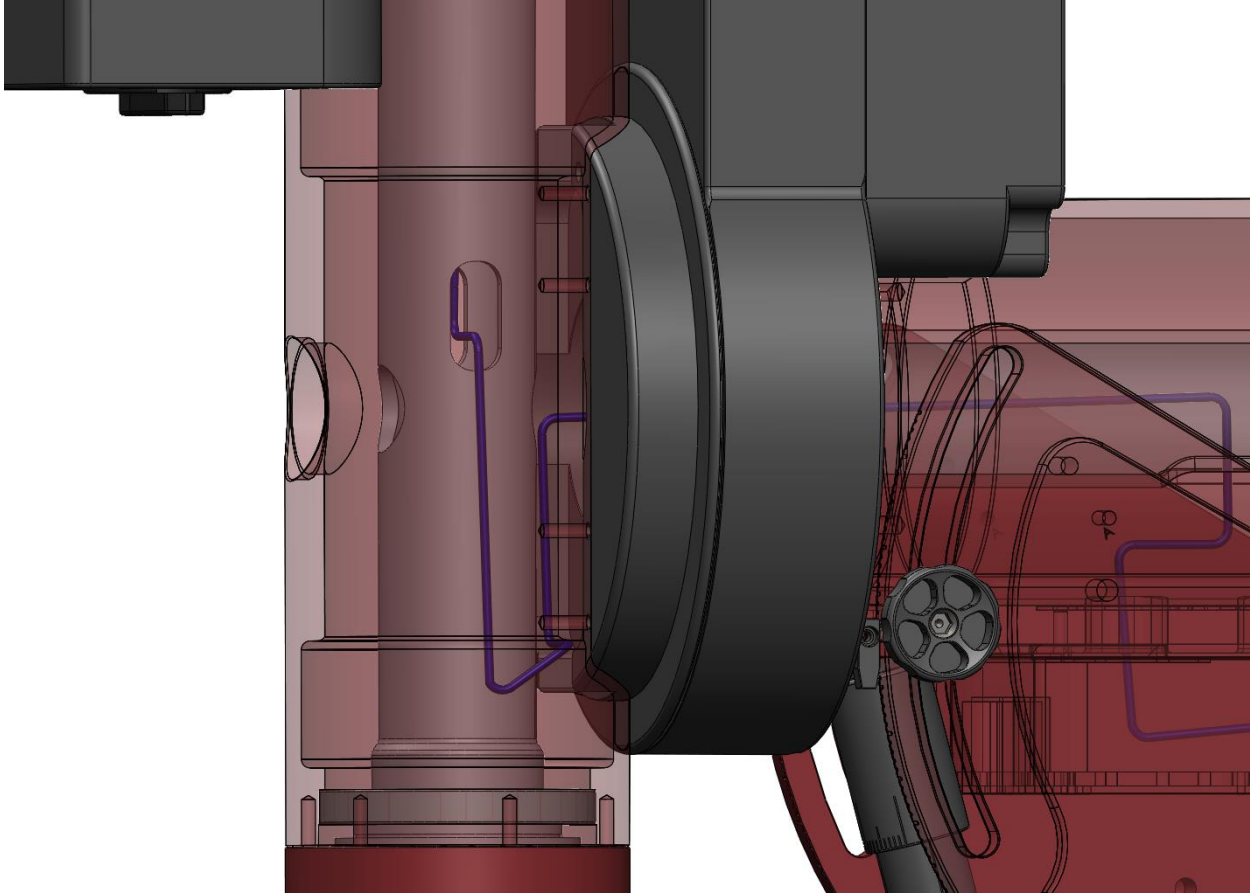

Figure 8: Close up view showing the proper routing of the through the Paramount MX and Paramount MX+ declination axis.



A 24-inch flexible wire grabber can help pull stiffer cables through the mount and up to the Instrument Panel, even when an OTA is in place.



Figure 9: A flexible wire grabber.

Routing Cables through the Paramount ME II

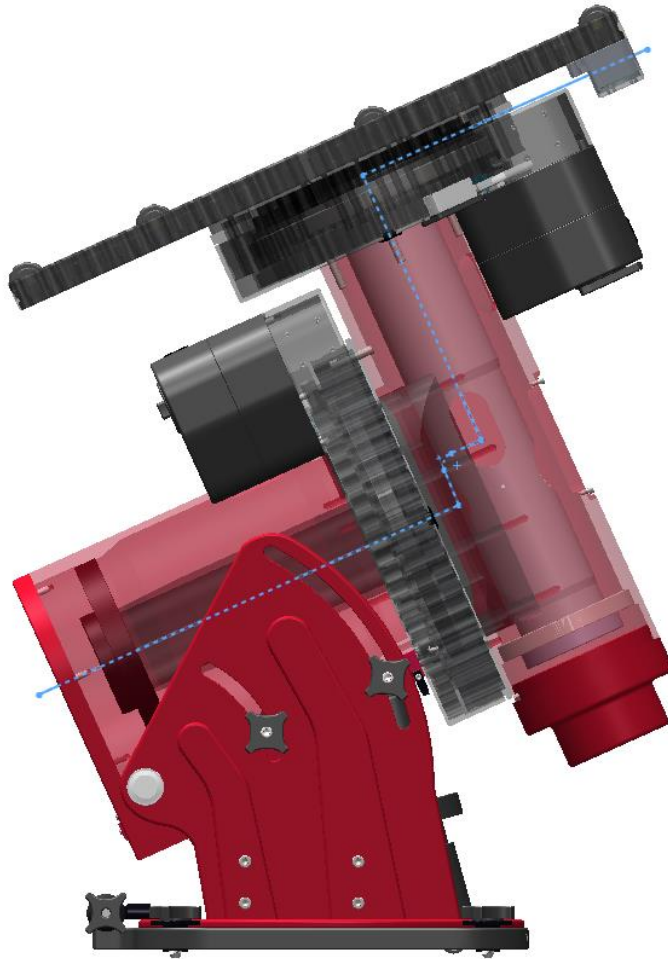

Figure 10: Paramount ME II cross section showing path of cable through the mount.

Routing custom cables through the Paramount ME II is a relatively straightforward procedure.

- Remove the two Right Ascension Rear Cover (Figure 19) mounting screws and the cover.
- Remove the two Cable Conduit Cover screws (Figure 43) and the cover.
- Attach a cable tie to the end of the cable to be installed (Figure 7).
- Insert the pointed end of the cable tie into the Right Ascension Cable Conduit and continue threading the cable upward, through the access hole in the declination axis until the cable tie can be grasped by hand, or by a flexible wire grabber inserted into the Cable Conduit Access Hole on the declination axis housing.
- Pull the cabling up and into the declination axis.
- Thread the cable tie up the declination shaft until it exits the top of the declination shaft. Once the cable tie can be grasped, continue pulling it outward until the cable itself exits the top of the axis.
- Thread the cable through the Instrument Panel access hole.

- Once the cable has been passed all the way through the mount, make an 8-inch loop in the cable and carefully tuck this loop inside the outer shaft of the declination assembly to allow the declination axis to rotate completely without any interference from the cable itself (see Figure 8). Rotating the declination axis from hard stop to hard stop more or less does the work for you, but allowing additional slack in the cable is recommended.

Note that this procedure can be performed with a telescope in place.

Routing Cables through the Paramount MyT

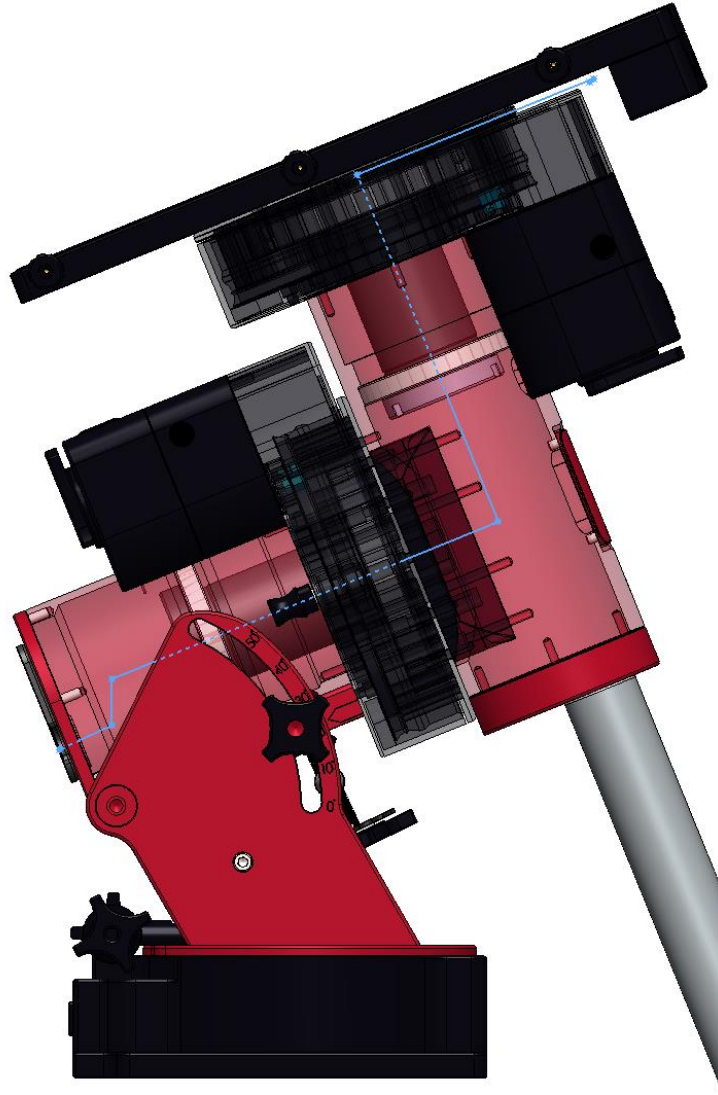

Figure 11: Paramount MyT cross section showing path of cable through the mount.

Compared to the both the Paramount MX, Paramount MX+, and Paramount ME II, routing custom cables through the Paramount MyT is an even more relatively straightforward procedure.

1. Remove the two Right Ascension Rear Cover (Figure 22) mounting screws and the cover.

2. Remove the two Cable Conduit Cover screws (Figure 46) and the cover.
3. Attach a cable tie to the end of the cable to be installed (Figure 7).
4. Insert the pointed end of the cable tie into the Right Ascension Cable Conduit and continue threading the cable upward, through the access hole in the declination axis until the cable tie can be grasped by hand, or by a flexible wire grabber inserted into the Cable Conduit Access Hole on the declination axis housing.
5. Pull the cabling up and into the declination axis.
6. Thread the cable tie up the declination shaft until it exits the top of the declination shaft. Once the cable tie can be grasped, continue pulling it outward until the cable itself exits the top of the axis.
7. Thread the cable through the gap between the Versa-Plate and gear. There are two 4-40 threaded holes on the instrument panel that can be used to create a strain relief for cables ran.
8. Unlike the Paramount ME II, Paramount MX and Paramount MX+, there is no need for a loop around the declination shaft. The shafts have been re-designed so the cables have a more straightforward path to the instrument panel.

Note that this procedure can be performed with a telescope in place.

Packing List

The Paramount is shipped in two separate boxes. The larger box (Box 1) contains the Paramount mount itself, the smaller box (Box 2) contains the User Guide, manual and mount accessories. Please make sure the following items are included in the Paramount boxes. In the event one or more items are missing, please contact Software Bisque (page 15) immediately to obtain a replacement.

Box 1 Contents

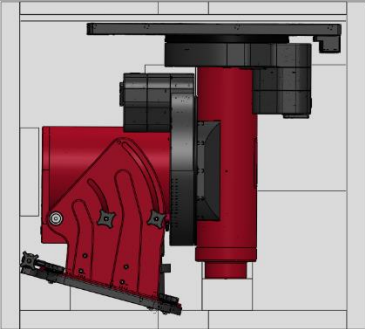
ME II		
Qty	Photo	Description
1		Paramount ME II Robotic Telescope Mount with Versa-Plate attached. Box Dimensions: 74 cm x 66 cm x 41 cm (29" x 26" x 16") Shipping Weight (including the Paramount ME II): 43 kg (95 lb.)

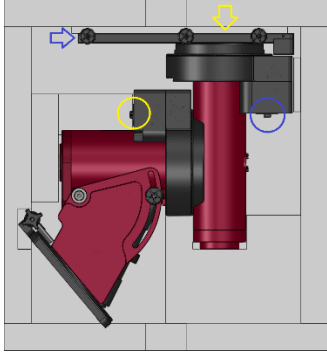
		
Qty	Photo	Description
1		<p>Paramount MX Robotic Telescope Mount with Versa-Plate attached.</p> <p>Box Dimensions:</p> <p>33 cm x 62 cm x 66 cm (13" x 24.5" x 26")</p> <p>Shipping Weight (including the Paramount MX): 29 kg (65 lb.)</p>

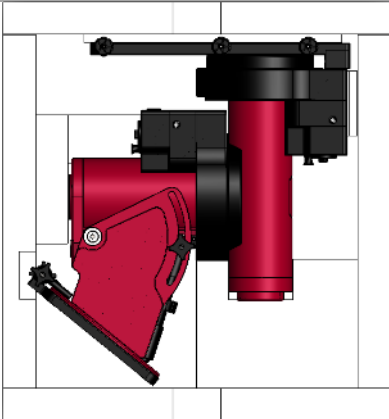

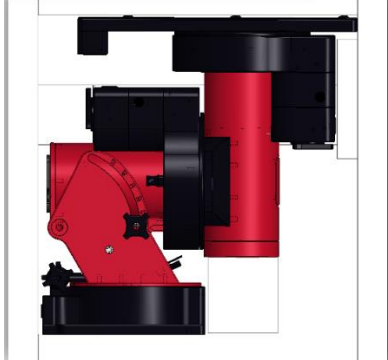

		
Qty	Photo	Description
1		<p>Paramount MX+ Robotic Telescope Mount with Versa-Plate attached.</p> <p>Box Dimensions:</p> <p>33 cm x 62 cm x 66 cm (13" x 24.5" x 26")</p> <p>Shipping Weight (including the Paramount MX+ mount): 32 kg (70 lb.)</p>





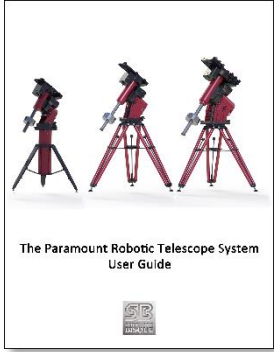

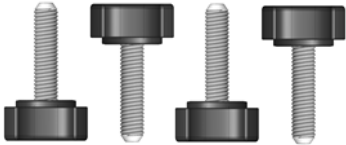
		
Qty	Photo	Description
1		<p>Paramount MYT Robotic Telescope Mount with Versa-Plate attached.</p> <p>Box Dimensions: 48 cm x 51 cm x 24 cm (19" x 20" x 9.5")</p> <p>Shipping Weight (including the Paramount MYT mount): 20.4 kg (45 lb.)</p>





Important Packing Material Notes



The Paramount is shipped encased in two ultra-dense white Styrofoam inserts inside two double-walled cardboard shipping boxes. Software Bisque strongly recommends that you keep both the shipping boxes and the two Styrofoam inserts as these packing materials are specifically designed to protect your mount during transport.

Box 2 Contents (Accessories Box)

Qty	Photo	Description
1		The printed Paramount User Guide.
1		USB 2.0 cable.
4		Base Thrust Mounting Knobs (page 86).
1		Hex key wrench set.

Qty	Photo	Description
1	 <p>Paramount ME II PSU</p>  <p>Paramount MX, Paramount MX+ and Paramount MYT PSU</p>	<p>Power Supply Unit (PSU).</p> <p> Paramount ME II (only): The separate <i>Power Supply Extension Cable</i> (shown in the next row) must be connected to the circular plug on the PSU before it can be used to supply power to the mount. <i>Do not plug the circular connector on the PSU into the Auxiliary Power Out port on the Electronics Box.</i></p> <p>See “Plugging Power Supply Unit into the Electronics Box” on page 82 for details.</p>
1		<p>Power Supply Extension Cable (Paramount ME II only).</p> <p>See “Plugging Power Supply Unit into the Electronics Box” on page 82 for details.</p>
1		<p>Power Cable for the Power Supply Unit (NEMA 5-15 male plug).</p>
1		<p>Hand Controller with joystick (page 111).</p>
1		<p>Counterweight Shaft (page 100).</p>
1		<p>Counterweight Safety Knob (page 105).</p>

Qty	Photo	Description										
												
<p>See table at right.</p>		<p>Counterweights (page 101).</p> <table border="1" data-bbox="729 562 1435 812"> <thead> <tr> <th data-bbox="735 569 862 600">Model</th> <th data-bbox="862 569 1429 600">Number of counterweights</th> </tr> </thead> <tbody> <tr> <td data-bbox="735 600 862 653">MEII</td> <td data-bbox="862 600 1429 653">Two 13.6 kg / 30 lb.</td> </tr> <tr> <td data-bbox="735 653 862 705">MX</td> <td data-bbox="862 653 1429 705">Two 9 kg / 20 lb.</td> </tr> <tr> <td data-bbox="735 705 862 758">MX</td> <td data-bbox="862 705 1429 758">Two 9 kg / 20 lb.</td> </tr> <tr> <td data-bbox="735 758 862 810">MYT</td> <td data-bbox="862 758 1429 810">One 9 kg / 20 lb.</td> </tr> </tbody> </table>	Model	Number of counterweights	MEII	Two 13.6 kg / 30 lb.	MX	Two 9 kg / 20 lb.	MX	Two 9 kg / 20 lb.	MYT	One 9 kg / 20 lb.
Model	Number of counterweights											
MEII	Two 13.6 kg / 30 lb.											
MX	Two 9 kg / 20 lb.											
MX	Two 9 kg / 20 lb.											
MYT	One 9 kg / 20 lb.											
<p>1</p>		<p>Paramount ME II (only) Altitude Adjuster Wrench (page 115).</p>										
<p>1</p>		<p>Paramount ME II (only) Accessory Pouch</p> <p>Use this pouch to store the following items:</p> <ul style="list-style-type: none"> • Two (2) 3/8" shoulder bolt hole plugs for holding the two (2) 5/16-in. x 2-1/4-in right ascension locking shoulder bolts and two (2) declination locking shoulder bolts. • Four (4) Delrin washers. When locking the Paramount ME II's right axis (page 91), use two of these washers to protect the surface of the mount from being marred by the steel shoulder bolts. • Four (4) plastic plugs to cover the outer side of the right ascension axis locking holes (page 91) and the declination axis locking holes (page 111). <p>The pouch can be conveniently stowed behind the Altitude Adjuster beneath the right ascension housing.</p>										
<p>1</p>		<p>Cable tie to help route cables through the mount (Figure 7).</p>										

Qty	Photo	Description
		
1		<ul style="list-style-type: none"> • One (1) Paramount Software Suite thumb drive in jewel box.

Locating Your Serial Numbers

The Paramount mount and the Paramount Software Suite serial number are printed on a card that is attached to the altitude adjuster (Figure 12). Please retain this card for your permanent records.

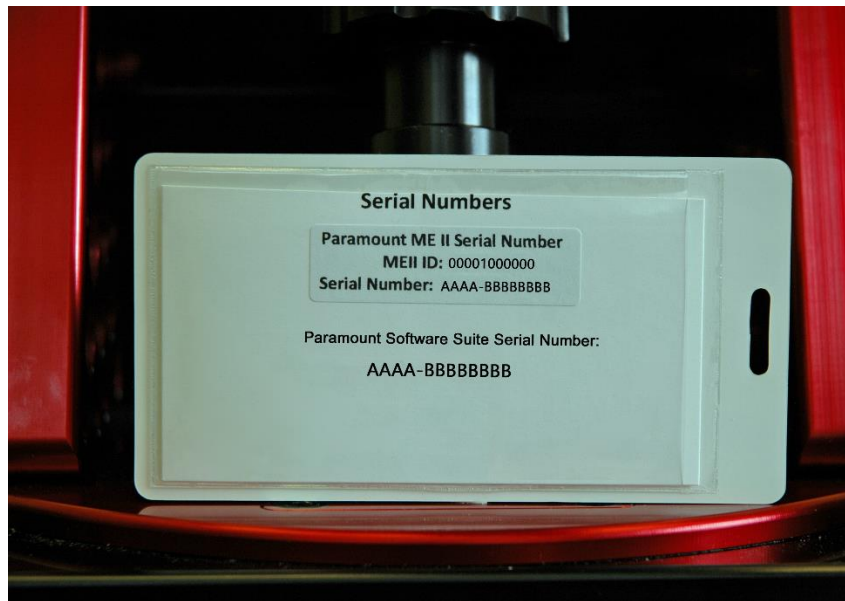

Figure 12: The Paramount serial numbers are attached to the altitude adjuster.



Before installing TheSkyX Professional Edition, please carefully read the *Paramount Quick Start Guide*, which is shrink wrapped to the printed user guide inside the Accessories Box. The PDF version can be downloaded from here:

<http://www.bisque.com/sc/media/p/77034.aspx>

Your *Paramount Software Suite serial number* should be entered the first time TheSkyX Professional Edition is launched. Doing so also automatically activates the Add Ons.

Paramount and Software Serial Number Registration

Please register the Paramount hardware and software serial numbers at:

<http://www.bisque.com/register>

Serial number registration gives your Software Bisque web account access to software installers, software updates, control system firmware updates (page 159) and the latest MKS 5000 USB drivers (page 181).



- Registering the Paramount serial number, alone, does not register the software suite, and is not sufficient to access software installers and updates. You must register both the Paramount serial number and the Paramount software suite serial number.
- Software Bisque does not automatically register serial numbers for you.

Unpacking the Paramount

We trust you are excited to unpack and start using your Paramount as soon as possible. Please resist the urge to simply remove everything from all the boxes, try to use the mount, and then consult the documentation only *after* something goes wrong. Taking a few moments now to review and understand the basic mount design will hopefully avoid potentially harmful accidents or damage to your mount.

Your Safety is Paramount

The Paramount is extremely rugged and designed to provide years of reliable service, but, like any precision instrument, you must become familiar with certain basic features and operating procedures to ensure proper use and your personal safety.



When you remove the packing tape on the Paramount shipping box, and lift the cardboard flaps, please stop and carefully read the enclosed insert (shown in Figure 14) *before removing the mount from the box!*

The insert describes very important basic mount features and the correct procedure to prepare the mount for handling once it has been removed from the shipping box.

Paramount ME II Unpacking Insert

! BOTH AXES ARE LOCKED BEFORE THE PARAMOUNT ME II IS BOXED FOR SHIPMENT

The Paramount ME II is shipped with both axes locked and the *Two Position Switch* in the *Balance Position*. (These switches are described in the middle column).

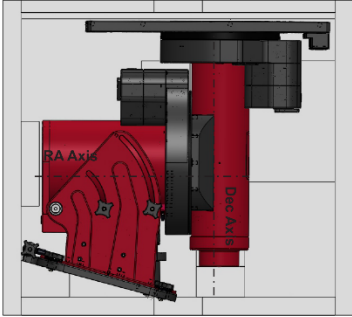

The RA Axis is locked by inserting two shoulder bolts and washers, then securing them with nuts. The Dec Axis is locked by two shoulder bolts screwed into the Dec gear. Remove these shoulder bolts only after counterweight shaft has been attached (see third column of this sheet).

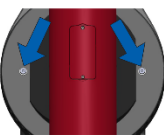
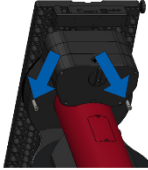

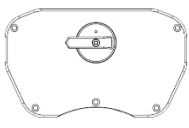

Locking the RA Axis Locking the Dec Axis

THE TWO POSITION SWITCH



Track Position





Balance Position



Lock Axis

The RA Axis and Dec Axis have an arrow-shaped knob as part of a rotatable, mechanical Two Position Switch. This switch can be rotated to one of two positions and each position places the mount in the operational state described below.

-  **Track Position** Rotate the switch fully counterclockwise to engage the worm with the gear for normal operation.
-  **Balance Position** Rotate the switch to the center position to disengage the worm from the gear for balancing the payload.
-  **Lock Axis** Remove shoulder bolts to unlock each axis.

! DO NOT PLACE THE TWO POSITION SWITCHES TO THE BALANCE POSITION UNLESS THE COUNTERWEIGHT SHAFT IS ATTACHED OR THE LOCKING SHOULDER BOLTS ARE IN PLACE!

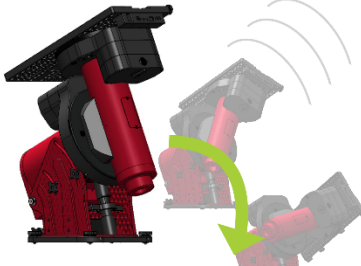
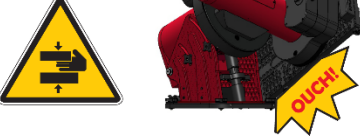
Without a counterweight shaft attached, the RA Axis is out of balance and "top heavy". The above diagram demonstrates what happens when the Two Position Switch is rotated to the Balance Position without the counterweight shaft attached.

To prevent sudden or unexpected rotation, remove locking shoulder bolts from the RA Axis only *after* attaching the counterweight shaft.

See the Paramount ME II User Guide for further details on setting up the Paramount ME II for first use.

Figure 13: Please carefully read the above flyer and the warning below *before* unpacking the Paramount ME II.

DANGER

**IMPROPER USE OF THE
PARAMOUNT ME II
CAN RESULT IN SEVERE
PERSONAL INJURY
OR DEATH!**

**Never remove the right
ascension or declination
locking bolts with the
counterweight shaft
removed, or when the
mount's payload is out of
balance!**

Paramount MX Unpacking Insert

! YOU MUST LOCK BOTH AXES BEFORE REMOVING THE PARAMOUNT MX FROM THE BOX!

The MX is shipped with both mechanical Three Position Switches in the Balance Position. The switches are highlighted by green and blue circles below, and described in the center panel.

To prevent mount damage or personal injury, BEFORE LIFTING THE MX FROM THE BOX, rotate both Three Position Switches to the Lock Position.

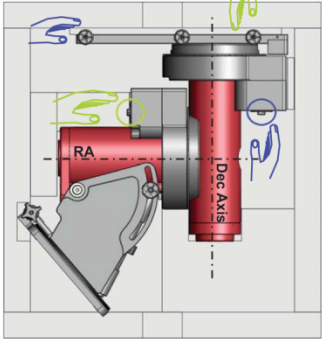

To Lock the RA Axis (green hands):

1. With your right hand grasp the top of the declination axis and gently wiggle it up and down.
2. While performing step 1, rotate the RA Axis Three Position Switch to the Lock Position.*

To Lock the Dec Axis (blue hands):

1. With your left hand grasp the end of the Versa-Plate and gently wiggle it up and down.
2. While performing step 1, rotate the Dec Axis Three Position Switch to the Lock Position.*

*The Three Position Switch drops slightly into the worm gear cover when the axis is locked.

THE THREE POSITION SWITCH

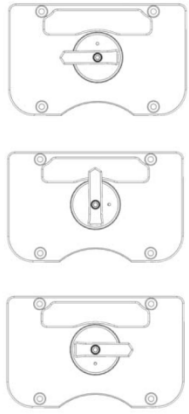

Track Position

Balance Position

Lock Position

The RA Axis and Dec Axis have an arrow-shaped knob as part of a rotatable, mechanical Three Position Switch. This switch can be rotated to one of three positions and each position places the mount in the operational state described below.

Track Position Rotate the switch fully counterclockwise to engage the worm with the gear.

Balance Position Rotate the switch to the center position to disengage the worm from the gear for balancing the payload.

Lock Position Rotate the switch fully clockwise to separate the worm from the gear and lock the axis in place.

! DO NOT ROTATE THE THREE POSITION SWITCH TO THE BALANCE POSITION UNLESS THE COUNTERWEIGHT SHAFT IS ATTACHED!

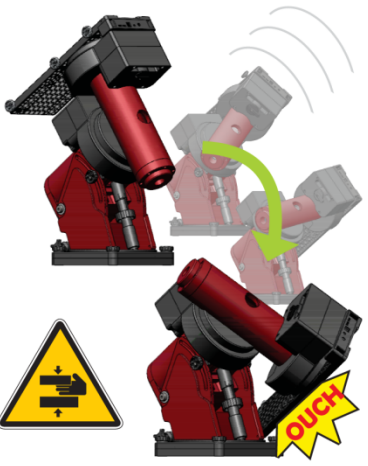

After locking both axes, carefully lift the Paramount MX from the box and set it upright on a flat, stable surface.

Without a counterweight shaft attached, the RA Axis is out of balance and "top heavy". The above diagram demonstrates what happens when the Three Position Switch is rotated to the Balance Position without the counterweight shaft attached.

To prevent sudden or unexpected rotation, unlock the RA Axis only after attaching the counterweight shaft.

See the Paramount MX User Guide for details on setting up the Paramount MX for first use.

Figure 14: Please carefully read this flyer before unpacking the Paramount MX.

Please see the "RA Worm Block Switch" on page 74 for details about using the three position switch.

Paramount MX+ Unpacking Insert

! YOU MUST LOCK BOTH AXES BEFORE REMOVING THE PARAMOUNT MX+ FROM THE BOX!

The MX+ is shipped with the Two Position Switches and Transport Lock Knobs in the Balance Position. (These are described in the next column).

To prevent mount damage or personal injury, BEFORE LIFTING THE MX+ FROM THE BOX, pull and rotate both transport lock knobs clockwise to the Lock Position. Do not rotate the Two Position Switch until ready to use mount.

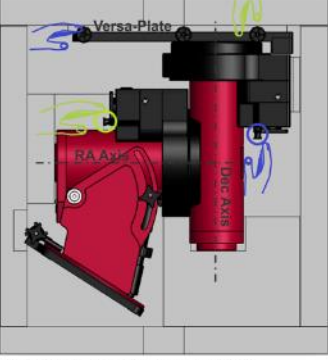

To Lock the RA Axis (see the green hands above):

1. With your right hand grasp the top of the Dec Axis and gently lift it up and down so that the RA Axis rotates slightly.
2. While performing step 1, use your left hand to pull and rotate the RA Axis Transport Lock Knob to clockwise to the Lock Position.*

To Lock the Dec Axis (see the blue hands above):

1. With your left hand grasp the end of the Versa-Plate and gently lift it up and down so that the Dec Axis rotates slightly.
2. While performing step 1, use your right hand to pull and rotate the Dec Axis Transport Lock Knob to clockwise to the Lock Position.*

After locking both axes, carefully remove the Paramount MX+ from the box and set it upright on a flat, stable surface. Carefully read the right-most column of this document before proceeding.

*The Lock Knob drops slightly into the worm gear cover when the axis is locked.

USING THE TWO POSITION SWITCH AND TRANSPORT LOCKING KNOB

The MX+ RA and Dec worm blocks include a circular Transport Lock Knob and an arrow-shaped, Two Position Switch. The Transport Locking Knob can lock the axis for transport; pull and always rotate this knob clockwise to switch from the lock to the free position. The knob itself will be slightly recessed in the worm block cover when the axis is locked. During normal operation, unlock the axis, then rotate the Two Position Switch to the Track position. Rotate the Two Position Switch to the Balance position to balance the payload.

Balance Position:

Pull out and rotate the transport lock knob 90 degrees clockwise until the knob sits in indents.

Rotate the switch to the center position to disengage the worm from the gear for balancing the payload.

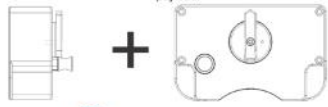

Lock Position:

Pull out and rotate the transport lock knob 90 degrees clockwise until the knob drops slightly into the worm block cover.

Rotate the switch to the center position to disengage the worm from the gear for balancing the payload.

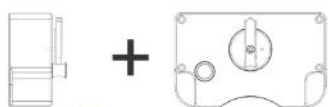

Track Position:

Pull out and rotate the transport lock knob 90 degrees clockwise until the knob sits in indents.

Rotate the switch fully counterclockwise to engage the worm with the gear for normal operation.



! Must be unlocked!

! DO NOT ROTATE THE LOCK KNOB AND TWO POSITION SWITCH TO THE BALANCE POSITION UNLESS THE COUNTERWEIGHT SHAFT IS ATTACHED!



Without a counterweight shaft attached, the RA Axis is out of balance and "top heavy". The above diagram demonstrates what happens when the Two Position Switch is rotated to the Balance Position and the lock knob is in the balance position without the counterweight shaft attached.

To prevent sudden or unexpected rotation, unlock the RA Axis only after attaching the counterweight shaft.

See the Paramount User Guide for further details on setting up the Paramount MX+ for first use.

Figure 15: Please carefully read this flyer before unpacking the Paramount MX+.

Please see the "RA Worm Block Switch" on page 74 for details about using the two position switch.

Paramount MyT Unpacking Insert

! YOU MUST LOCK BOTH AXES BEFORE REMOVING THE PARAMOUNT MyT FROM THE BOX!

The MyT is shipped with the *Two Position Switches and Transport Lock Knobs* in the *Balance Position*. (These are described in the next column).

To prevent mount damage or personal injury, **BEFORE LIFTING THE MyT FROM THE BOX**, pull and rotate both **transport lock knobs** clockwise to the **Lock Position**. **Do not** rotate the **Two Position Switch** until ready to use mount.

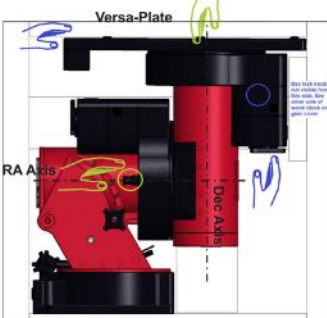

To Lock the RA Axis (see the green hands above):

- With your right hand grasp the top of the Dec Axis and gently lift it up and down so that the RA Axis rotates slightly.
- While performing step 1, use your left hand to pull and rotate the RA Axis Transport Lock Knob to clockwise to the Lock Position.*

To Lock the Dec Axis (see the blue hands above):

- With your left hand grasp the end of the Versa-Plate and gently lift it up and down so that the Dec Axis rotates slightly.
- While performing step 1, use your right hand to pull and rotate the Dec Axis Transport Lock Knob clockwise to the Lock Position.* The Dec Axis Transport Lock Knob is not visible from the diagram, but is located on the other side of the worm block on the Dec gear cover.

After locking both axes, carefully remove the Paramount MyT from the box and set it upright on a flat, stable surface. Carefully read the right-most column of this document before proceeding.

*The Lock Knob drops slightly into the gear cover when the axis is locked.

USING THE TWO POSITION SWITCH AND TRANSPORT LOCKING KNOB

The MyT has two mechanical switches on each axis that work together to either engage the worm for normal use, lock the axis for transport or disengage the worm to balance the payload. The arrow shaped Two Position Switch engages or disengages the worm. The circular Transport Lock Knob is used to prevent axis rotation for transport; pull and rotate this knob clockwise to lock or free the axis, slightly recessed in the worm block cover when the axis is locked. During normal operation, unlock the axis, then rotate the Two Position Switch to the Track position. Rotate the Two Position Switch to the Balance position to balance the payload.

Balance Position:

Pull out and rotate the Transport Lock Knob (shown in blue below) 90 degrees clockwise until the knob sits in indents.



Lock Position:

Pull out and rotate the transport lock knob 90 degrees clockwise until the knob drops slightly into the worm block cover.



Track Position:

Pull out and rotate the transport lock knob 90 degrees clockwise until the knob sits in indents.



! Must be unlocked!

! WITH NO COUNTERWEIGHT ATTACHED DO NOT ROTATE THE LOCK KNOB AND TWO POSITION SWITCH TO THE BALANCE POSITION!



Without a counterweight shaft attached, the RA Axis is out of balance and "top heavy". The above diagram demonstrates what happens when the Two Position Switch is rotated to the Balance Position and the Transport Lock Knob is also in the balance position with no counterweight attached.

To prevent sudden or unexpected rotation, unlock the RA Axis only after attaching the counterweight shaft.

See the Paramount User Guide for further details on setting up the Paramount MyT for first use.

Figure 16: Please carefully read this flyer before unpacking the Paramount MyT.

The Paramount MyT right ascension axis can be locked at one of three unique orientations (Figure 17).

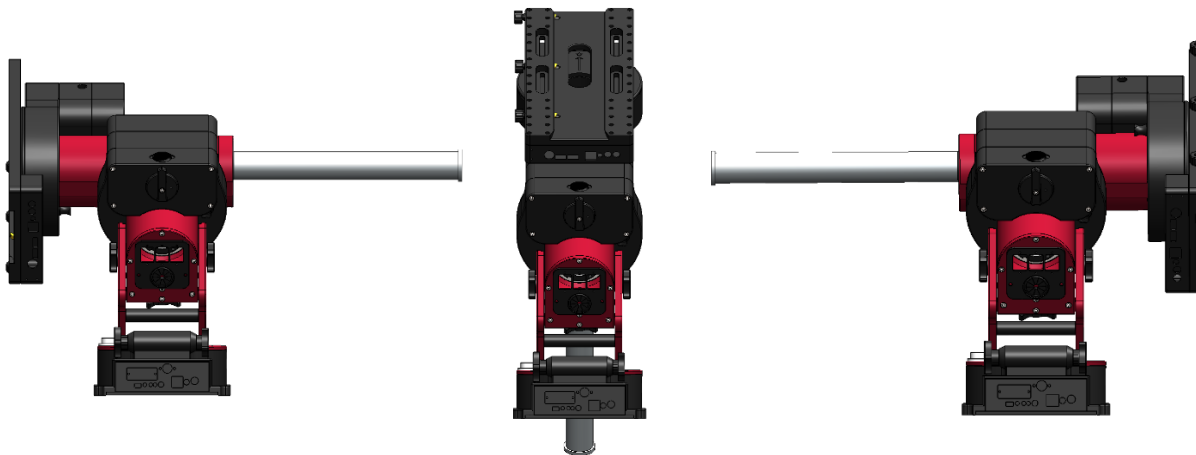

Figure 17: The three Paramount MyT right ascension axis locking positions.

- The counterweight shaft is horizontal and the optical tube assembly side of the right ascension axis is on the west side of the pier.
- The counterweight is oriented vertically.
- The counterweight shaft is horizontal and the optical tube assembly side of the right ascension axis is on the east side of the pier.

The declination axis can be locked at one of four unique positions, each 90 degrees apart (Figure 18).

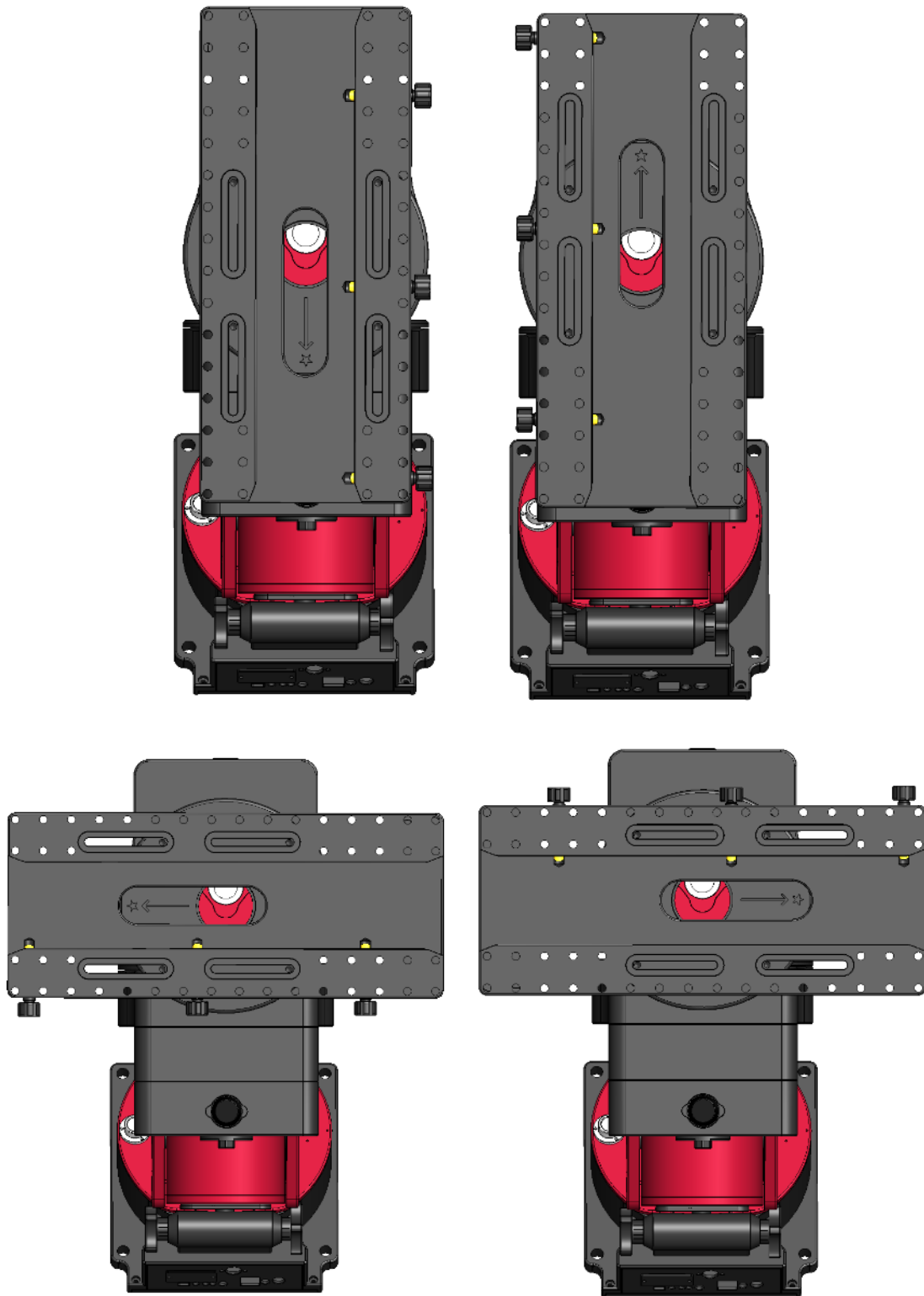





Figure 18: The four Paramount MxT declination axis locking positions.

1. When the declination axis is rotated fully *clockwise*, and the long axis of the Versa-Plate is parallel to the wedge plates.
2. Starting from the orientation in Step 1, rotate the Versa-Plate 90 degrees counterclockwise.
3. Starting from the orientation in Step 1, rotate the Versa-Plate 180 degrees counterclockwise.
4. Starting from the orientation in Step 1, rotate the Versa-Plate 270 degrees counterclockwise.





Packing the Paramount for Transport

Always make sure to perform the following steps when packing up the Paramount for shipment or transport.

1. Place the right ascension axis mechanical switch in the Balance position.
2. Rotate the right ascension axis so that the counterweight shaft is “down”.
3. Lock the right ascension axis so that it cannot rotate when the mount is lifted off the pier or tripod.

Model	How to lock axis...
	Install the locking shoulder bolts (page 91).
	Rotate the right ascension axis three position switch to the Lock position.
	Pull and rotate the transportation lock knob clockwise to the Lock position.
	Pull and rotate the transportation lock knob clockwise to the Lock position.

4. Carefully remove the payload from the Versa-Plate.
5. Carefully remove the counterweight safety knob.
6. Carefully remove the counterweights.
7. Carefully remove the counterweight shaft.
8. Rotate the Versa-Plate *fully clockwise* to the hard stop position. In this position, the Versa-Plate is parallel to the sides of the mount so that the mount will lay flat in the box. Note the physical hard stops prevent the declination axis from fully rotating 180 degrees. If the declination axis is rotated fully *counterclockwise*, the edge of the Versa-Plate will not be parallel with the sides of the mount, and will not lay flat in the box.
9. Remove the four Base Thrust Mounting Knobs.
10. Lift the mount off the pier or tripod and gently place it in the packing foam.
11. Unlock both axes before shipment. The shipping box may be dropped, or experience other excessive forces during shipment. Allowing the axes to rotate helps prevent possible damage to the locking mechanisms.

Model	How to unlock axis...
	Remove the locking shoulder bolts (page 91).
	Rotate the right ascension axis and declination axis Three Position Switch to the Balance position.
	Pull and rotate the transportation lock knob clockwise to the Balance position and make sure the worm and gear are disengaged by rotating both axis a few degrees back and forth.
	Pull and rotate the transportation lock knob clockwise to the Balance position and make sure the worm and gear are disengaged by rotating both axis a few degrees back and forth.

Paramount Components

Please carefully review and become familiar with each Paramount component *before* attempting to operate the mount.

Paramount ME II Front View

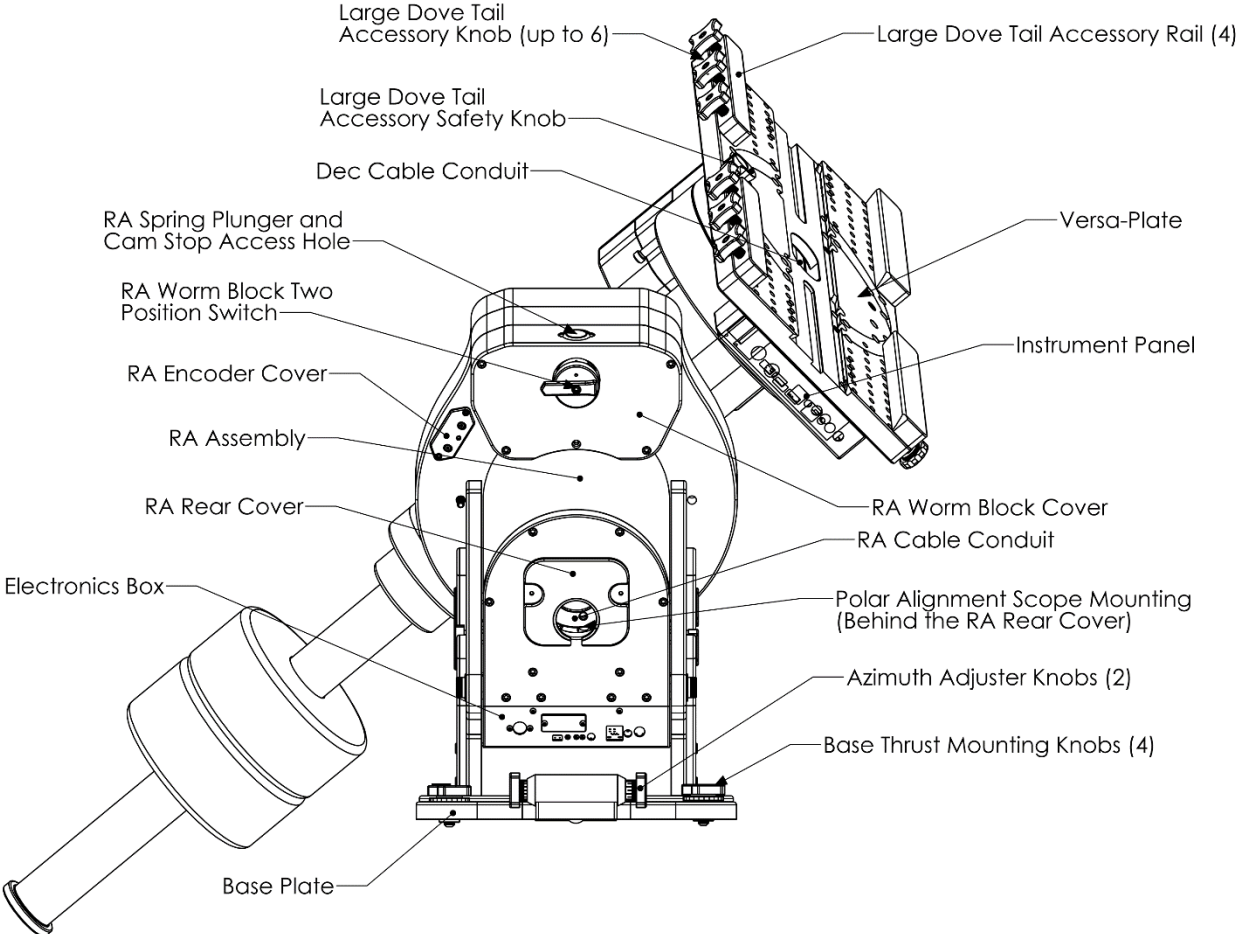

Figure 19: The front view of the Paramount ME II.

Paramount MX Front View

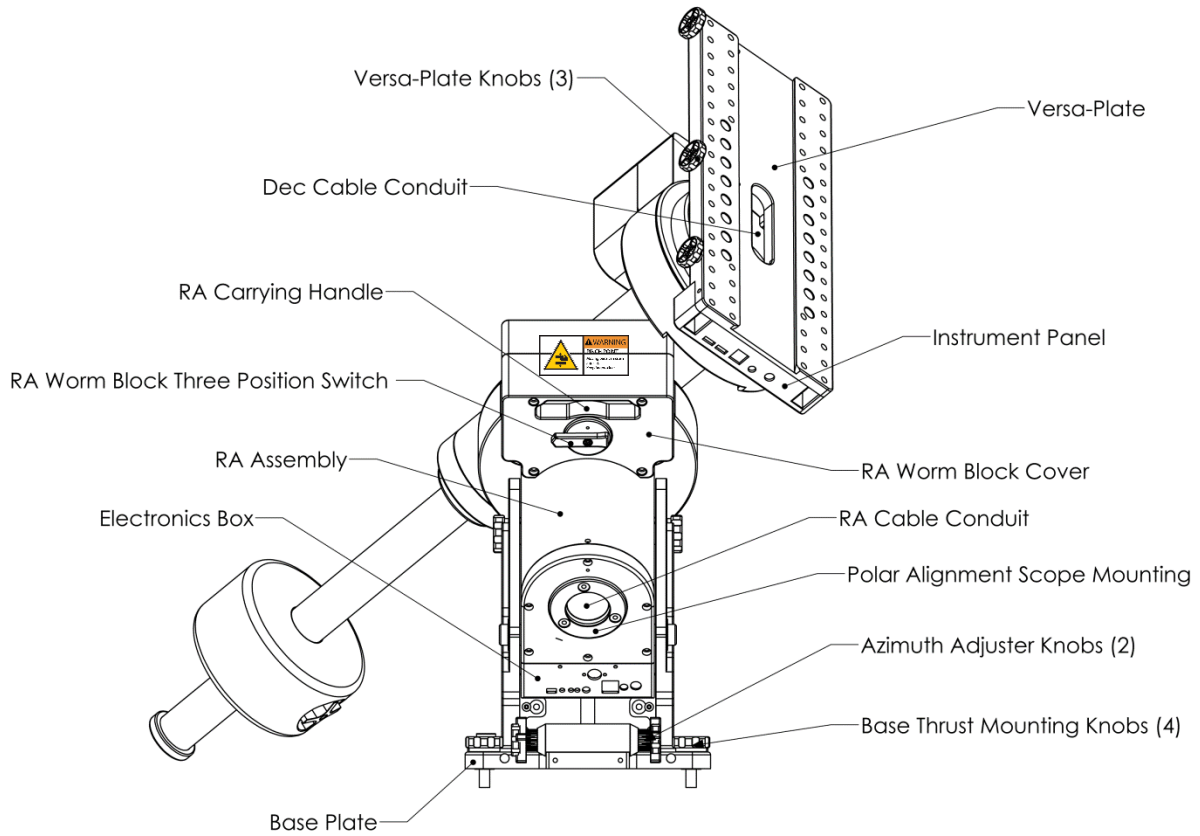

Figure 20: The front view of the Paramount MX.

Paramount MX+ Front View

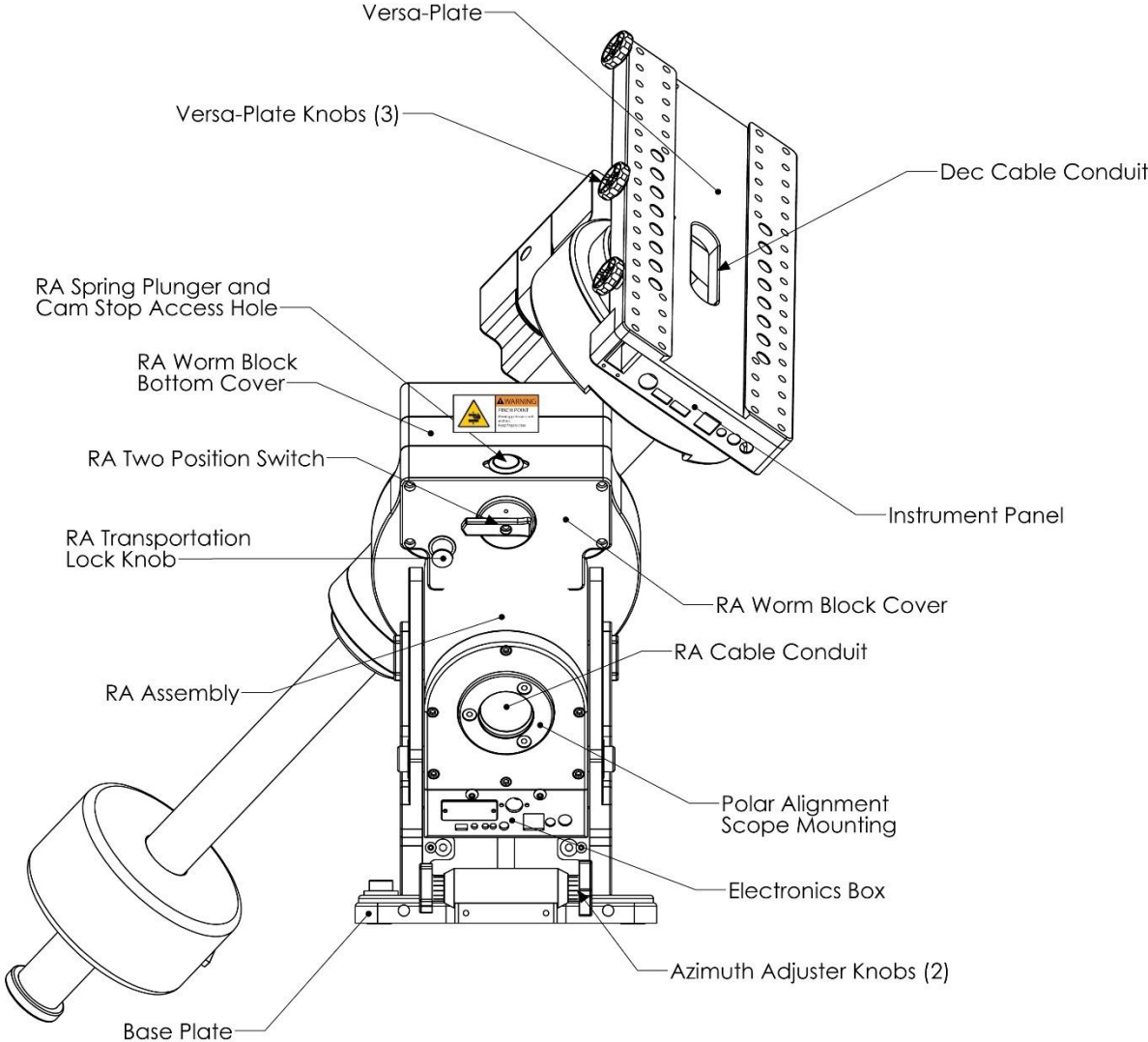

Figure 21: The front view of the Paramount MX+

Paramount MyT Front View

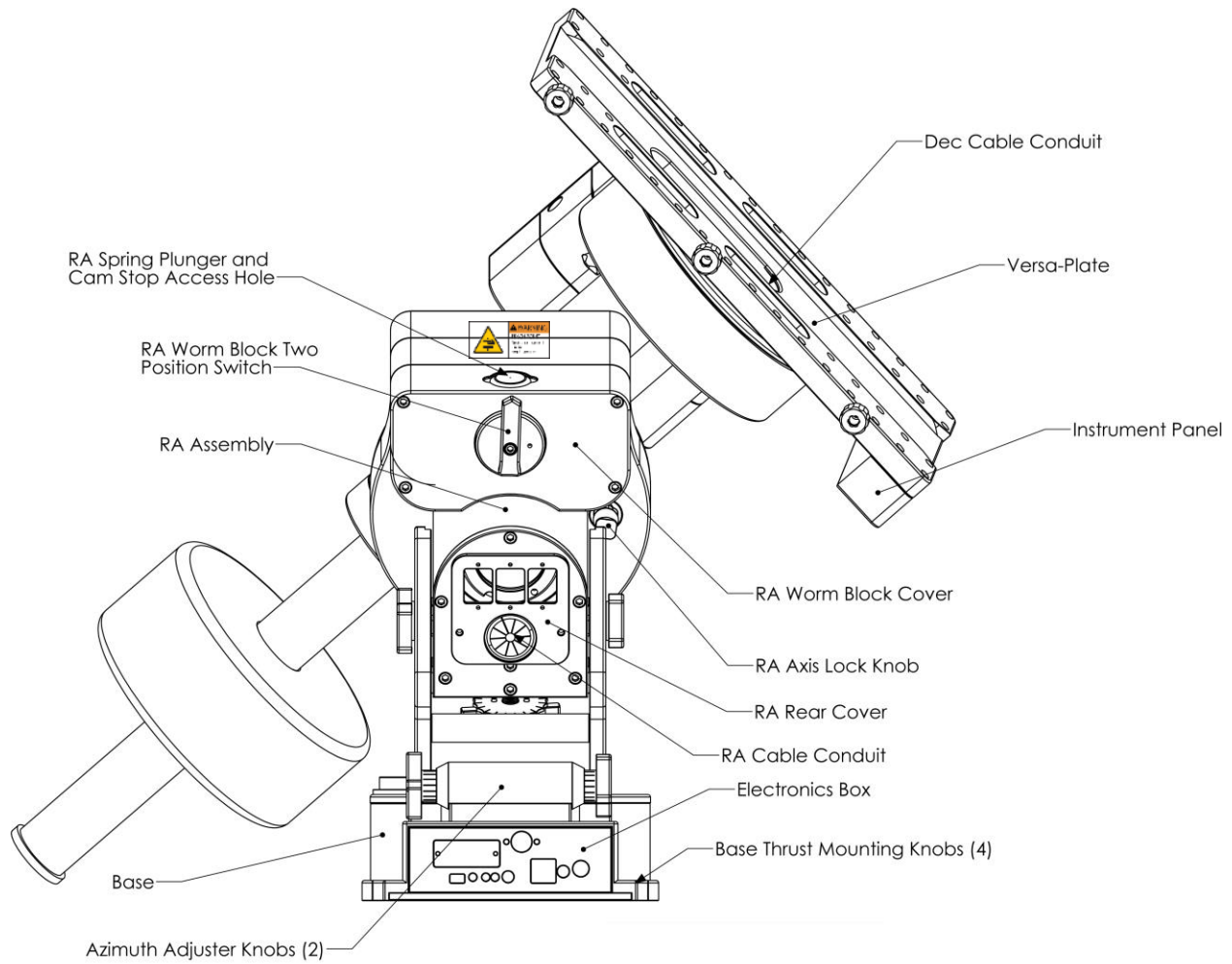

Figure 22: The front view of the Paramount MyT.

RA Worm Block Cover



Always keep hands and fingers away from the right ascension axis worm block cover!

A “pinch point” is created as the declination axis rotates past the right ascension axis worm block cover.

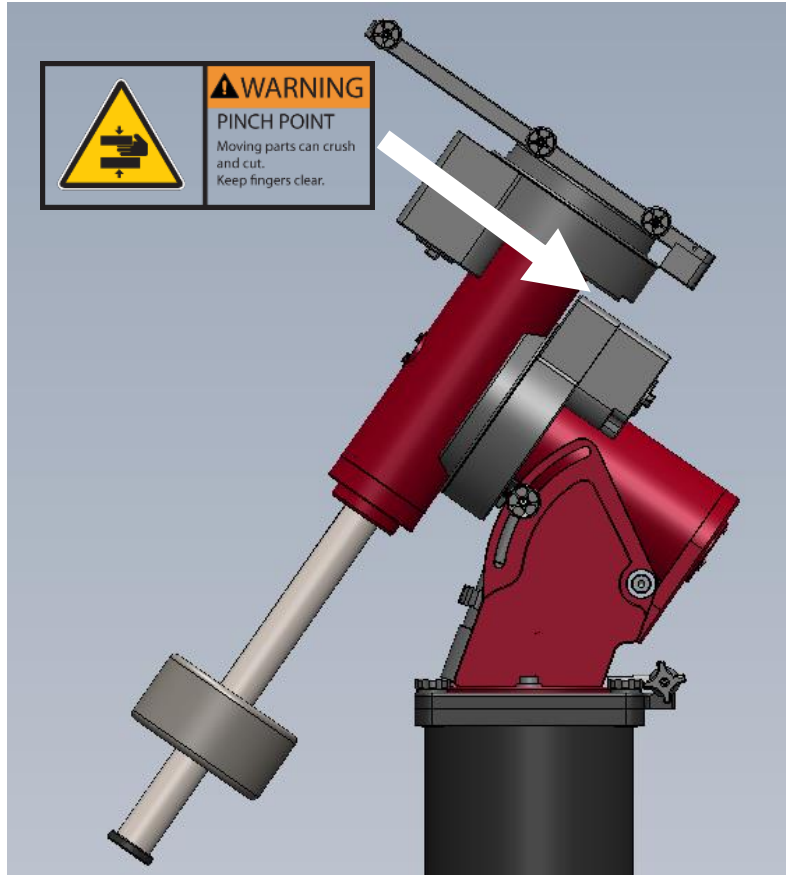

Figure 23: Caution: Always keep hands clear of this area!

Payload Mounting Plate (Versa-Plate)

The Paramount Versa-Plate provides a stable mounting platform to carry a variety of astronomical equipment. The optical tube assembly can be attached using the integrated Losmandy and Celestron dovetail rail-compatible dovetail, a telescope cradle, or telescope mounting rings. The Instrument Panel (page 68) mounted to the bottom rear of the Versa-Plate places power ports, two USB 2.0 ports, and custom through the mount cables near the camera-end of the telescope, right where they're needed.

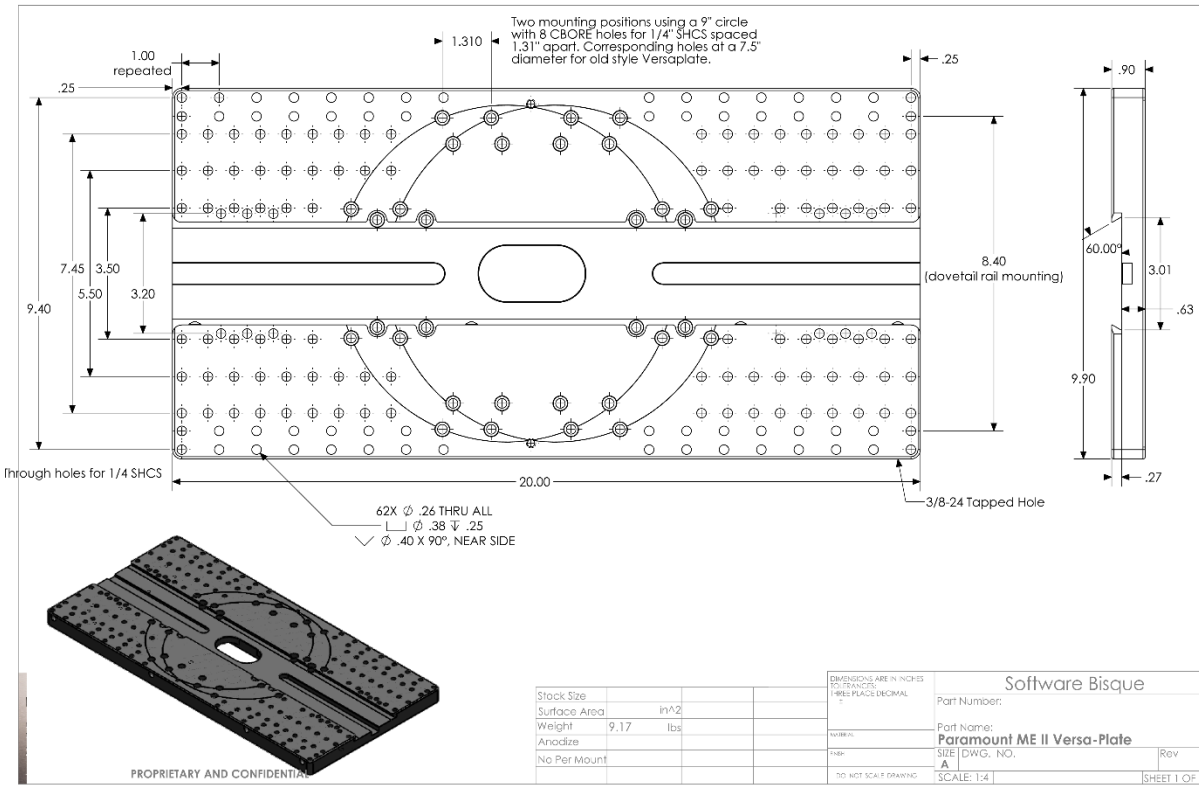

Figure 24: The Paramount ME II Versa-Plate technical specifications.

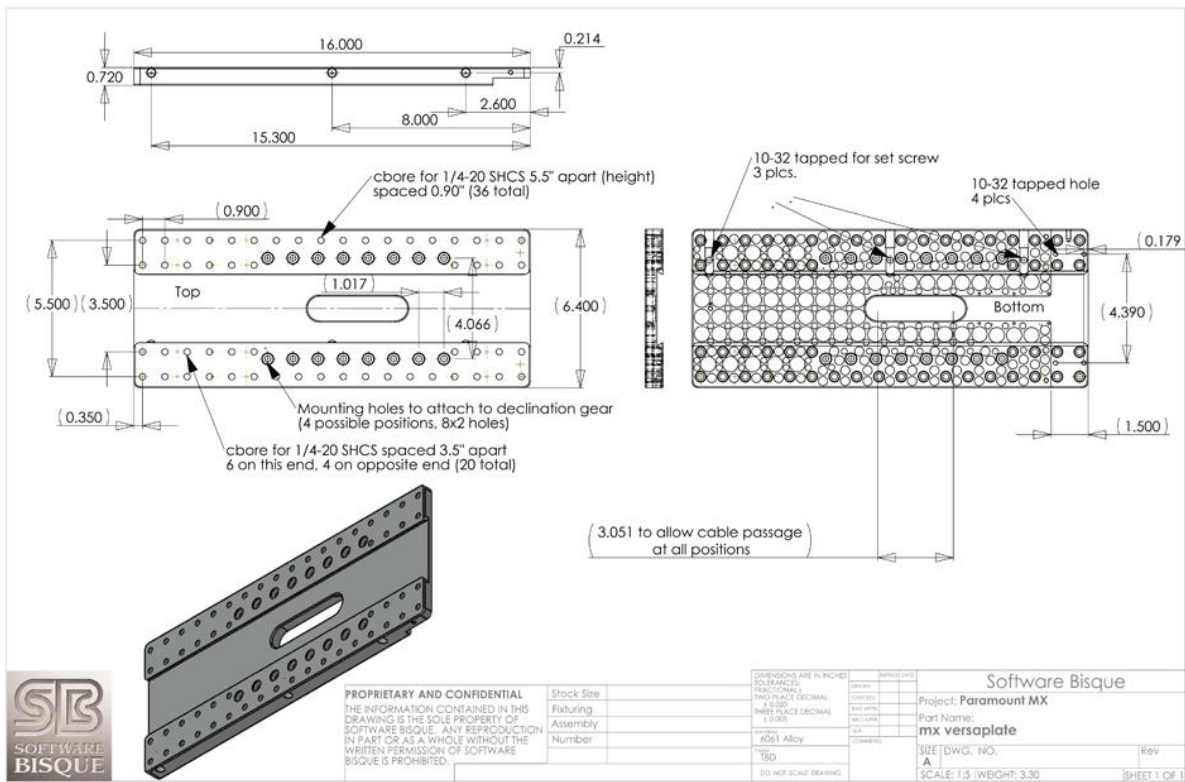

Figure 25: The Paramount MX and MX+ Versa-Plate technical specifications.

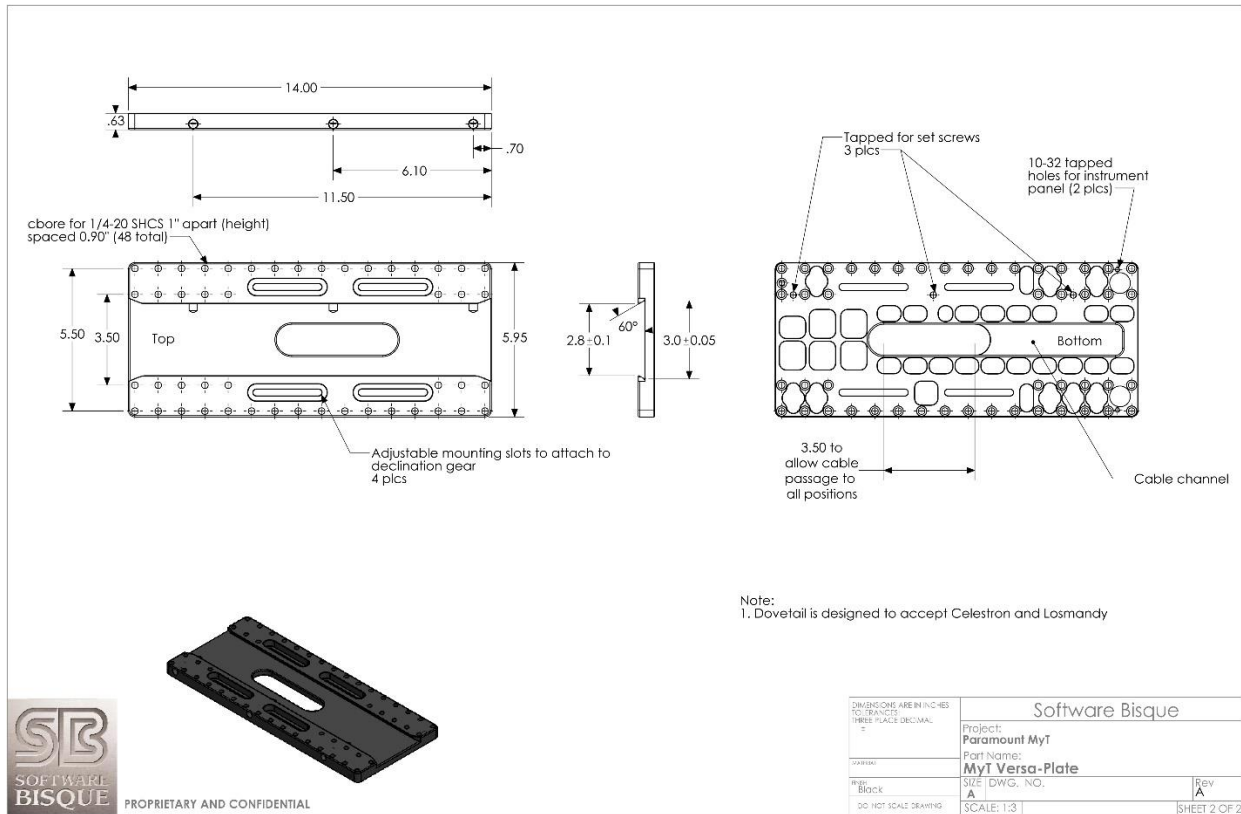

Figure 26: The Paramount MyT Versa-Plate technical specifications.

The table below lists the most common hardware used to mount telescopes (or *optical tube assemblies*) and the advantages and disadvantages of each system.

OTA Mounting	Advantages	Disadvantages
Losmandy-compatible Dovetail	<ul style="list-style-type: none"> Mounting the OTA to the Versa-Plate is relatively fast and easy. Hardware is available, or integrated into telescopes from several different manufacturers, including: <ul style="list-style-type: none"> ADM Accessories Celestron International Losmandy Astronomical Products Meade Instruments Officina Stellare 	<ul style="list-style-type: none"> Dovetails are not always rigidly mounted to the OTA itself. This can introduce flexures that affect overall pointing accuracy and repeatability.





OTA Mounting	Advantages	Disadvantages
Parallax Instruments OTA Tube Rings	<ul style="list-style-type: none"> Extremely rigid mount-to-telescope attachment. Allows multiple optics to be rigidly mounted. Repeatable all sky pointing. 	<ul style="list-style-type: none"> Hardware is usually more expensive.

Paramount Versa-Plate Knobs

The Versa-Plate Knobs (three on the Paramount MX, Paramount MX+ and Paramount MYT, four on the standard Paramount ME II; up to six with the optional Large Dovetail Accessory Rail) are designed to securely captivate a male Losmandy-compatible dovetail. Rotating the knob clockwise advances an angled brass plunger on the inside of the dovetail. The angled brass plunger wedges the male dovetail to the opposite side of the female dovetail to prevent any slippage or rocking of the payload, regardless of the mount’s orientation.

To mount an OTA with a male dovetail to the Versa-Plate:

1. With the counterweight shaft oriented vertically, lock the right ascension axis in place.

Model	How to unlock axis...
	Install the right ascension locking bolts and rotate the right ascension Two Position Switch to the Balance position (page 91).
	Rotate the right ascension axis Three Position Switch to the Lock position (page 74).
	Rotate the right ascension axis Two Position Switch to the Balance position (page 74) and pull and rotate the Transport Lock Knob to the Lock position (page 74).
	Rotate the right ascension axis Two Position Switch to the Balance position (page 74) and pull and rotate the Transport Lock Knob to the Lock position (page 74).

2. Carefully slide the male dovetail on the OTA into the Versa-Plate’s dovetail until the OTA is approximately balanced in the declination axis.



Figure 27: The brass plunger compresses the male dovetail (from left to right in the above diagram).

3. *Hand tighten* each Versa-Plate knob until the brass plungers securely hold the dovetail in place. While tightening the knobs, push slightly on the OTA in the same direction as the advancing brass plungers to make sure the dovetail plate is securely compressed against opposite side of the dovetail wedge (Figure 27). Also ensure that the male dovetail plate is securely captivated by **at least two** of the Versa-Plate Knobs before letting go of the OTA or testing declination axis balance. Securing a heavy or expensive payload with one knob is not sufficient. The length of the male dovetail varies by manufacturer. For best results and when the length of the male dovetail permits, always tighten all three knobs to hold it securely in place.
4. Test the declination axis balance, then make adjustments to the position of the payload as needed.
5. After the payload in the declination axis is balanced and the knobs are hand tightened, definitively secure each knob by inserting a 1/4-in hex wrench and tighten it an additional *one-quarter turn only*. **Do not over tighten these knobs or the internal threads can be damaged.** Note that when two or three of the knobs are “hand tightened”, the dovetail will not slide. The final 1/4 turn with the hex wrench ensures that your heavy and expensive payload is mounted securely and will not move when the mount slews.

Versa-Plate Mounting Positions

The Paramount MX, MX+, ME II and MyT Versa-Plate can be mounted to the top of the declination axis in four different positions to move the balance point of different payloads. The gray circles in Figure 28 represent the top of the declination axis at each mounting position.

If your payload is “camera-end heavy,” mount the Versa-Plate at the forward most position so that the payload can be more easily balanced. Remove the six 1-inch socket head cap screws (SHCS) using a 3/16-in hex wrench, then adjust the position of the Versa-Plate accordingly. The mounting position depends on your equipment, so there may be a bit of trial and error to find the optimal spot. The four SHCS should be tightened snugly so that the Versa-Plate cannot wiggle or shift when carrying the payload, but not too tight.

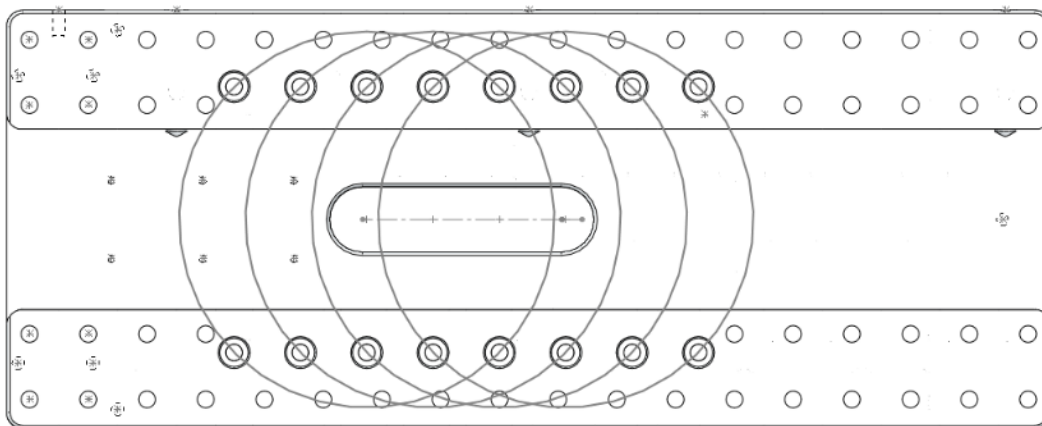

Figure 28: Machined circles mark the four mounting positions on the Paramount MX and Paramuont MX+ Versa-Plate. (The Instrument Panel end is to the left.) The Paramount ME II's Versa-Plate has two mounting positions.

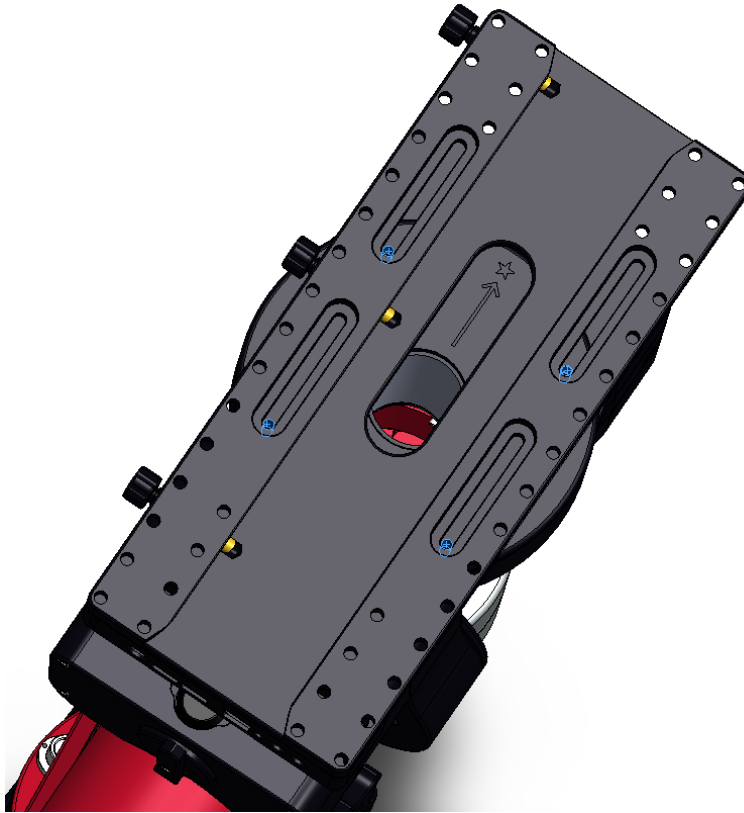

Figure 29: The Versa-Plate mounting slots on the Paramount MyT allow the payload to be adjusted to achieve balance in declination.

The Paramount MyT Versa-Plate has four slots that can be used to adjust the balance point of the payload in declination. To do so, loosen the four ¼-20 SHCS screws using a 3/16-in. hex wrench, then slide the Versa-Plate to the desired position. Once balance has been achieved, snugly tighten each screw enough so that the Versa-Plate does not rotate or shift during mount slews, but not so tight as to deform the washers.

Standard versus Wide Mounting Versa-Plate Orientation

The Paramount is shipped with the Versa-Plate in the standard orientation. The Versa-Plate can also be mounted at 90 degrees from the standard orientation, offering a wider mounting area to accommodate multiple optical tube assemblies.



The Instrument Panel is attached to the bottom of the Versa-Plate. Typically, you will want to mount the optical tube assembly to the Versa-Plate so that the eyepiece or camera end is as close to the Instrument Panel as possible. Doing so offers the shortest cable route between powered accessories that are mounted to the draw tube and the power ports on the Instrument Panel.

The standard Versa-Plate mounting configuration works well for Schmidt-Cassegrain, Ritchie-Chretien, and refracting telescopes where the “business end” naturally places equipment near the Instrument Panel.

For Newtonian telescopes and other optical designs, where the camera and other accessories are located toward the “front” of the telescope, the Versa-Plate can be rotated 180 degrees so that the devices are closer to the Instrument Panel.

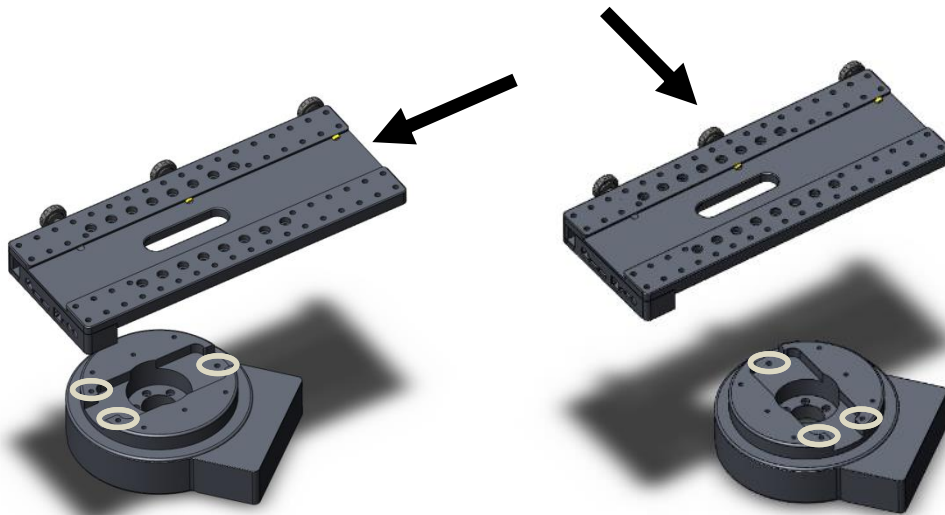

Figure 30: The standard (left) and wide (right) Versa-Plate mounting orientations for the Paramount MX.

Figure 30 shows one standard and one wide orientation of the Versa-Plate, relative to the top of the Paramount MX declination axis. For each orientation, the black arrow shows the direction *incoming light* passes through the optical tube assembly when it is mounted to the Versa-Plate.

When mounting the Versa-Plate on the Paramount MX, pay very close attention to the mounting holes on the top of the declination axis. The three circled holes in Figure 30 form a triangle that must point toward the stars, or, in the *opposite* direction of the OTA’s incoming light.

Notice that for the both the standard and wide orientations, there are symmetrical mounting holes on the top of the declination axis that allow the Versa-Plate to be attached 180 degrees apart; either one can be used, depending on your needs. However, when mounting the OTA, make sure to maintain the relative orientation between the top of the declination axis and the direction of incoming light described above. Otherwise, the telescope will not point in the correct direction.

To help make sure the Versa-Plate is mounted properly, early model Paramount mounts had an arrow machined into the top of the declination axis that represented the *direction of incoming light*. The top of the declination axis on later model Paramount ME II, Paramount MX+ mounts, and all Paramount MYT mounts have an *arrow and star* machined into the top of the declination axis (Figure 30). The *arrow points*

in direction of the stars. The optical tube must be mounted parallel to this arrow, with the light gathering end (or the *entrance pupil*) of the telescope located in the direction the arrow is pointing, toward the star.



If the optical tube assembly is attached to the Versa-Plate such that the OTA's direction of incoming light does not align with the direction of incoming light for the declination axis, homing the mount will result in the optical tube pointing somewhere besides hour angle 2 and declination 0. Remove both the OTA and the Versa-Plate to ensure both are mounted properly.

To change the orientation of the Versa-Plate from the standard to the wide configuration:

1. Remove the six 1-inch $\frac{1}{4}$ -20 $\frac{3}{16}$ socket head cap screws on the top of the Versa-Plate.
2. Rotate the Versa-Plate 90 degrees. The top of the declination axis has “indentations” to accommodate the Instrument Panel-specific and custom through the mount cabling.
3. Align the mounting holes on the Versa-Plate with the mounting holes at the top of the declination axis and replace four of the six screws. Only four socket head cap screws are used in the wide orientation.
4. When mounting the OTA, make sure that the direction of incoming light for the OTA corresponds with the required direction of incoming light for the declination axis as described above.



Mounting the Versa-Plate in the wide orientation reduces the cross-sectional area for cabling to pass through on the top of the declination axis by about one-third. While there is still some space for the standard cables and a few custom cables, be aware that there is less “wobble room” compared to the standard orientation.

Software Bisque manufactures and sells an optional *Paramount ME II Dec Axis to Versa-Plate Spacer* that provides additional room for through the mount cabling. See *Versa-Plate Cable Spacers (Paramount ME II only, Optional Accessory)* on page 69 for details.

A simple test to make sure the OTA is mounted properly is to home the mount. Once the homing process is completed, if the telescope is not pointing at hour angle 2 and declination 0, the OTA mounted incorrectly. To correct this situation,

1. Remove both the OTA and the Versa-Plate.
2. Double-check the orientation of the Versa-Plate with the top of the declination axis.
3. Double-check the direction of incoming light of the OTA with the orientation of the three holes on the top of the declination axis (Paramount MX) or the machined arrow on the top of the declination axis (Paramount ME II and Paramount MX+).
4. Rotate the OTA and/or Versa-Plate and remount them so that these three components are properly aligned. If necessary, home the mount with no payload and no Versa-Plate attached, then appropriately reattach both.

Versa-Plate Cable Spacers (Paramount ME II only, Optional Accessory)

Software Bisque offers optional spacers that can be used when the Paramount ME II Versa-Plate is mounted in the wide orientation. When mounted to the top of the declination axis, the spacers create a channel through which instrument cabling can be passed. Spacers can also be used in the standard position allowing more “clearance” for instrument cabling. On the Software Bisque Store page, search for “spacer”, or visit the URL below to purchase this product:

<http://www.bisque.com/sc/shops/store/MEIIVersaPlateSpacers.aspx>.

Large Dovetail Accessory Rail (Paramount ME II only, Optional Accessory)

The Paramount ME II can accept optical tube assemblies with a PlaneWave Instruments dovetail mounting plate using the optional Large Dovetail Accessory Rails. Four “rails” and the rotating safety knob mount directly to the existing Versa-Plate and offer six mounting knobs to securely attach and carry 20-inch class optical tubes. The safety knob allows a heavy optical tube assembly to be mounted by placing one edge of the male side of the dovetail into place, then rotating the telescope to meet the other side, rather than having to slide the entire payload along the length of the dovetail. Once the OTA is in place, rotate the safety knob to *temporarily* captivate the OTA and then proceed to tighten each Versa-Plate knob until the OTA is secure.

Instrument Panel

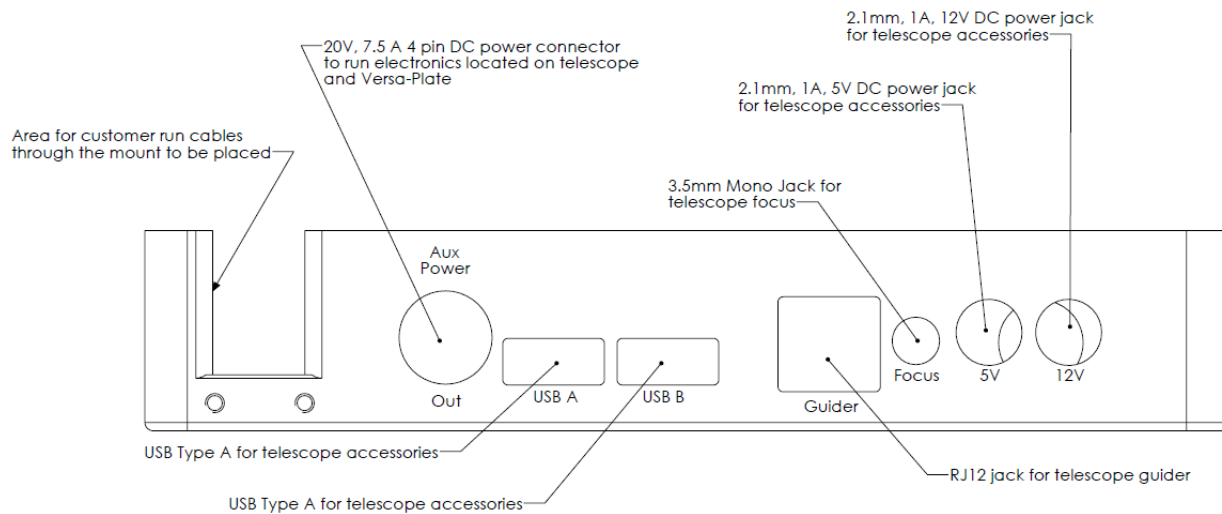

Figure 31: The Instrument Panel housing is mounted to the bottom of the Versa-Plate.

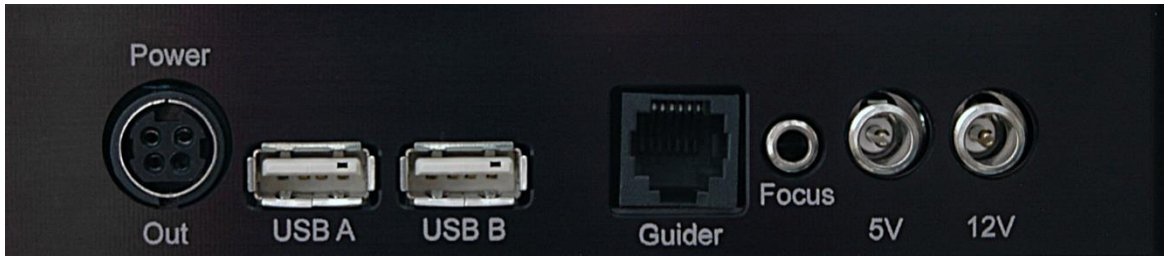

Figure 32: Photograph of the Instrument Panel.

Instrument Panel Components

The Instrument Panel provides two USB 2.0 ports, a guider port, a focuser for pulse focuser control and ports that can be used to supply power to your devices.

Powering Devices (Power Out)

The Instrument Panel port labeled *Power Out* is the *output* port for the mount’s built-in through the mount power cabling. The input port for the through the mount cabling is labeled *Power In* on the Electronics Box (page 80).

These ports are designed to satisfy the power requirements for a variety of DC-powered astronomical devices, including dew heaters, video cameras, and other instruments.



The Paramount External power ports and through the mount cabling is intended to be used with direct current (DC) power sources only. Never attempt to power devices through the mount with an alternating current (AC) power source.

The “stock” through the mount cabling for this connector uses 18-gauge AWG wires to carry relatively heavy DC loads and the 4-pin Kycon KPPX-4p series connectors (Mouser part number 806-KPPX-4P) are rated to carry a maximum of 20 volts at 7.5 amps.



The External Power connectors on the Instrument Panel and on the Electronics Box **do not supply power** nor do they have anything to do with the Paramount MX or Paramount MX+ power supply.

These connectors act as a conduit to route an external power source that is connected to the Power In connector located Electronics Box to the Power Out connector on the Instrument Panel.

Software Bisque offers cable sets that can be used to route power through the mount for many model cameras, as well as a generic “pig tail” cable set if you want to supply power to different device. See “Appendix C: External Power Cable Sets” on page 189 for these cable specifications.

If you plan on making your power own cables, the KPPX series snap and lock power connectors have many advantages, including:

- Self-locking
- Small footprint
- Inexpensive
- Readily available
- Rated for relatively heavy power loads
- Available in board mount or straight-through configurations

Search for “KPPX video assembly” on the [Kycon web site](#) for printed and video-based assembly instructions.

USB Ports (USB A and USB B)

These two USB ports are part of an integrated USB hub on the MKS 5000 electronics board. The Instrument Panel’s two USB ports can connect any two USB 2.0 devices to a computer’s USB port.

To allow USB communication between these ports and the computer, plug the square end of the mini-USB cable to the Electronics Box’s mini-USB port and the flat end into your computer’s USB port. Next, plug the rectangular end of the device’s USB cable into either USB A or USB B and power on the mount.



Both USB ports on the Instrument Panel are powered by the Paramount control system.

If a USB camera plugged into one of these ports and the mount’s power is turned off, the USB camera will no longer be able to communicate with the computer that is connected to the mini USB port on the Electronics Box.

Guider Port (Guider)

This RJ12 port is based on pin outs from the standard SBIG guider connector that is used by virtually every astronomical camera. See the “*Guide Port*” section of the [SG-4 Autoguider Operating Manual](#) for the SBIG autoguider port specifications.

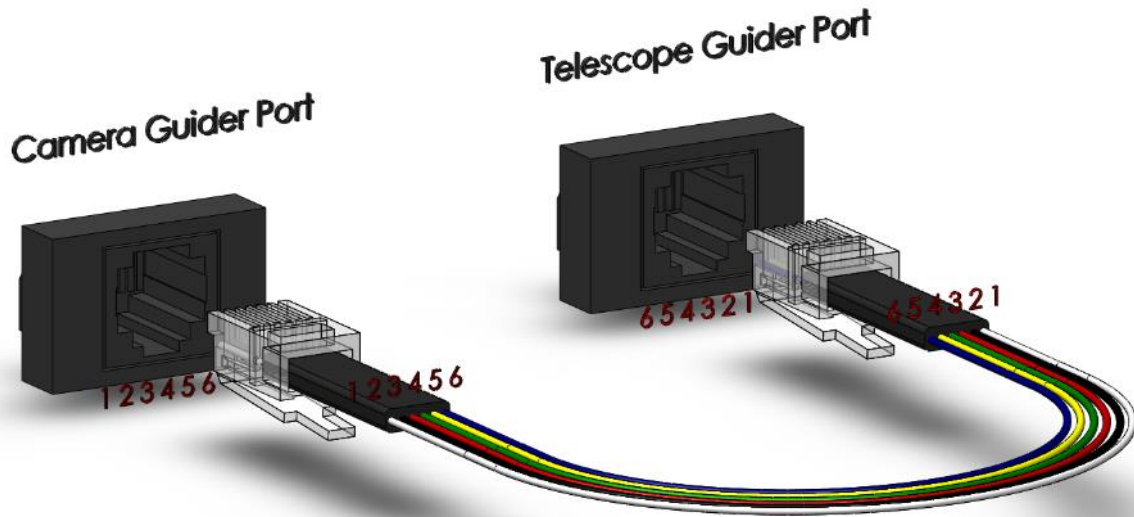

Figure 33: Diagram showing the pin outs for the guider cable and the camera and guider port.

Plug one end of the standard guider cable into the camera’s guider port, and the other end into the Instrument Panel’s Guider port.



Autoguiding, which involves monitoring the position of a guide star and adjusting the mount’s position as the star moves, has traditionally be performed using a guider cable attached to the camera’s guider port and the telescope’s guider port as described above.

Software Bisque’s DirectGuide feature eliminates “relay based” autoguiding. A Paramount mount, coupled with TheSkyX Professional Edition and the Camera Add On configured to autoguide using DirectGuide makes guider ports obsolete. DirectGuide details can be found in TheSkyX Professional Edition User Guide.

Focuser Port (Focus)

Use this port to connect your pulse focuser to the mount so that *TheSkyX Professional Edition* or other software (using *TheSkyX Professional Edition* as a server) can be used to “remotely” adjust the focuser’s position.

Plug the pulse focuser into this port, establish communication with the Paramount, then use the **Focus Controls** on *TheSkyX Professional Edition’s Telescope* window to adjust focus.

5 Volt Power Jack (5V)

The Instrument Panel port labeled **5V** can supply power for devices that require up to 5W (+5V DC at 1A max.).

Power to this unfused 2.1 mm female port is *supplied by the MKS 5000 control system*, so the mount must be plugged in and turned on for it to be operational. Compatible 2.1 mm male DC power plugs include:

1. Mouser part number 1710-0721 (no locking collar)
2. Mouser part number 171-7391 (locking collar)



1. Attempting to power a device through this port that draws more than 5W (5V at 1A max.) will cause the MKS 5000 control system to emit successive beeps, indicating an “error condition.”
2. The *total* power supplied to *both* the 5V and 12V ports is 12W (+12V DC at 1A max.). When using both ports to power devices, make sure that the combined power required by each device does not 12W.

If this occurs, the device should be powered using the OEM, or other sufficiently rated power source.

12 Volt Power Jack (12V)

The Instrument Panel port labeled **12V** can provide power to devices that require up to 12W (+12V DC at 1A max.).

Power to this unfused 2.1 mm female port is *supplied by the MKS 5000 control system*, so the mount must be plugged in and turned on for it to be operational. Compatible 2.1 mm male DC power plugs include:

3. Mouser part number 1710-0721 (no locking collar)
4. Mouser part number 171-7391 (locking collar)



- Attempting to power a device through this port that draws more than 12W (12V at 1A max.) will cause the MKS 5000 control system to emit successive beeps, indicating an “error condition.”
- The *total* power supplied to *both* the 5V and 12V ports is 12W (+12V DC at 1A max.). When using both ports to power devices, make sure that the combined power required by each device does not 12W.

If this occurs, the device should be powered using the OEM, or other sufficiently rated power source.

RA Worm Block Cover

The RA Worm Block Cover incorporates the following features:

- Protects the internal right ascension worm block components from dust and debris.
- Provides a convenient handle to grasp when lifting the mount.
- Houses the right ascension axis Three Position Switch (page 74).

RA Cable Conduit

This access hole in the right ascension shaft allows custom cables to be passed through the mount. See “Through the Mount Cabling” on page 35 for more information.

This access hole is dome-shaped to serve as an integrated carrying handle and is covered by the RA Gear Cover.

RA Gear Cover (ME II Only)

The RA Gear Cover provides an access hole for through the mount cables.

Dec Cable Conduit

This access hole in the declination shaft allows custom cables to be passed through the mount. See “Through the Mount Cabling” on page 35 for more information.

Right Ascension Carrying Handle

Use the integrated carrying handle to lift the mount. On the Paramount MX, place the Three Position Switch in the Lock position before lifting the mount. The Paramount ME II’s RA Cable Conduit access hole is dome-shaped and serves as the integrated carrying handle (remove the RA Gear Cover to access it). The Paramount MX+ has no integrated carrying handles but underneath the electronics box can serve as an aid when carrying the mount.

RA Worm Block Switch

The Paramount’s RA and Dec Axis have an arrow-shaped knob as part of a rotatable, mechanical switch. (The Paramount ME II and Paramount MX+ switch has two positions and is referred to as the Two Position Switch. The Paramount MX switch has three positions and is referred to as the Three Position Switch). This switch can be rotated to one of two or three positions and each position places the mount in a different operational state as described in the table below.



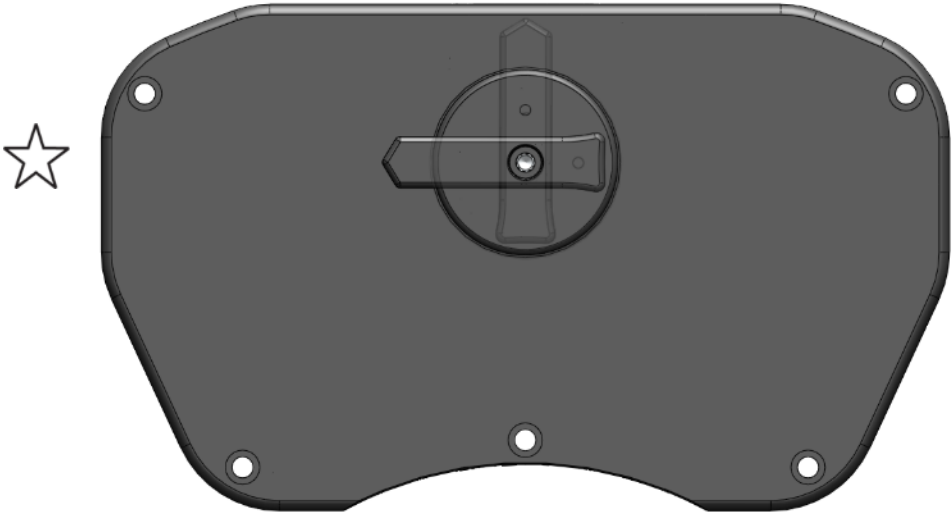

Figure 34: The Paramount ME II Two Position Switch.

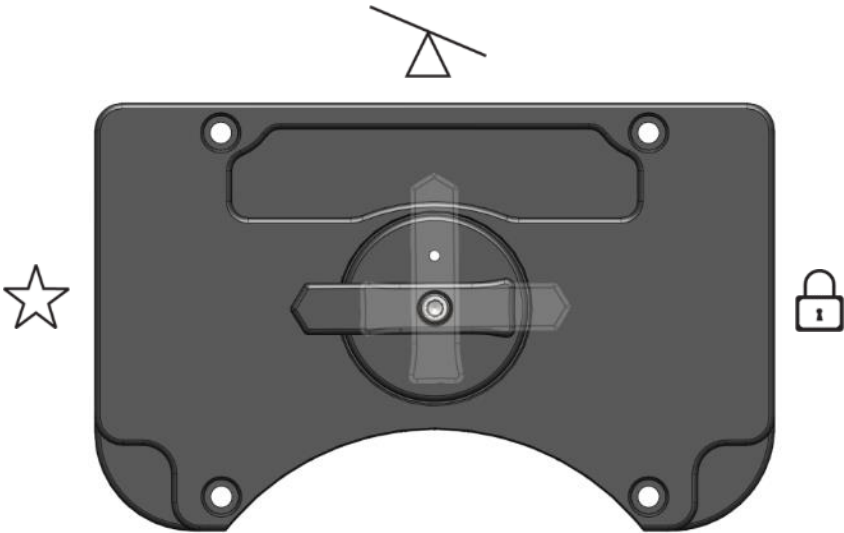

Figure 35: The Paramount MX Three Position Switch.



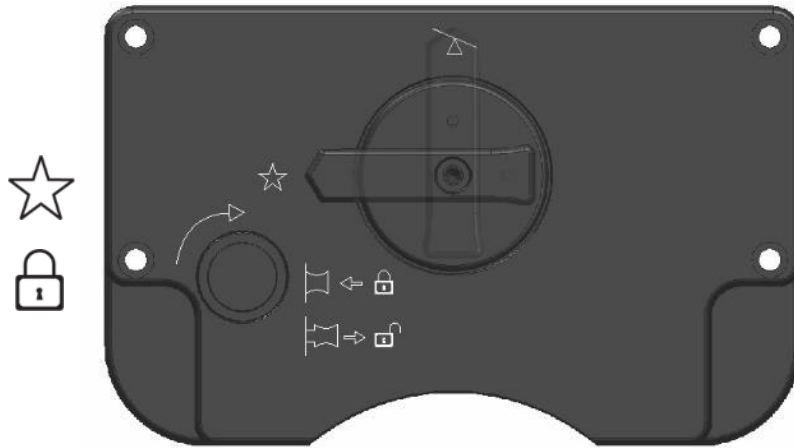

Figure 36: The Paramount MX+ Two Position Switch and Transport Lock Knob.

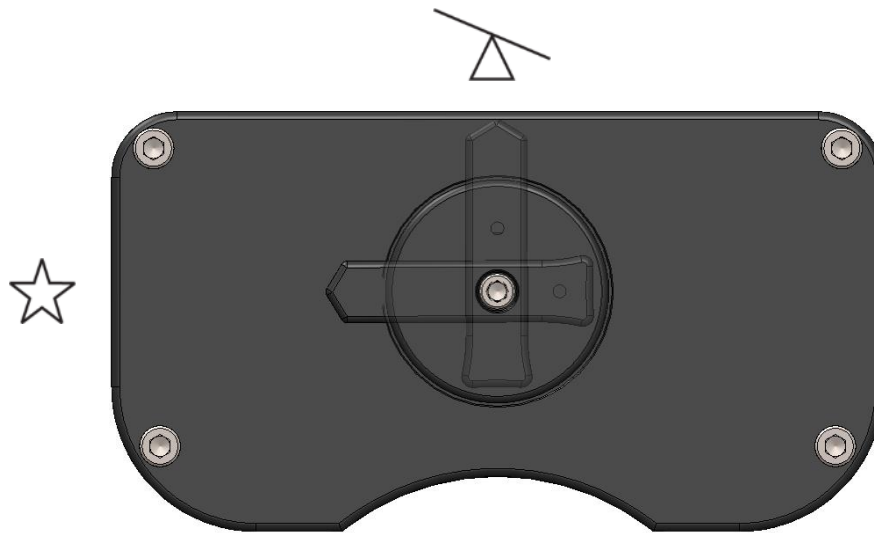





Figure 37: The Paramount MyT Two Position Switch.

Model	Mechanical Switches
	<p>When the Two Position Switch (Figure 34) is in the Balance position, the worm and gear are separated so the axis can rotate freely. When the switch is rotated to point at the star, the mount is ready for normal operation.</p> <p>Separate locking bolts must be installed lock the axis in place. See “Right Ascension Axis Locking Hole (Paramount ME II Only)” on page 91 and “Declination Axis Locking Hole (Paramount ME II Only)” on page 111 for details about locking the Paramount ME II axes.</p>
	<p>The balance, star and lock symbols shown are etched into the top of the cover of the Paramount MX, where they are most visible when setting up the mount (Figure 35).</p>
	<p>The Balance, Star, and Lock positions (Figure 36) are etched on the front of the Paramount MX+ worm block covers. The arrow-shaped Two Position Switch is used to balance and</p>

Model	Mechanical Switches
	<p>track; the circular Transport Lock Knob is used to lock the axis during transport, or free the axis during normal use.</p> <p>Notes:</p> <ul style="list-style-type: none"> • The Transport Lock Knob is slightly recessed in the lock position. • The Transport Lock Knob should always be rotated clockwise when locking or unlocking the axis.
	<p>When the Two Position Switch (Figure 37) is in the Balance position, the worm and gear are separated, so the axis can rotate freely. When the switch is rotated to point at the star (Track position), <i>and</i> the Transport Lock Knob is in the unlock position, the mount is ready for normal operation.</p> <p>Notes:</p> <ul style="list-style-type: none"> • The Transport Lock Knob is slightly recessed in the lock position. • The Transport Lock Knob should always be rotated clockwise when locking or unlocking the axis.



ADJUSTING THE PARAMOUNT’S MECHANICAL SWITCHES ALWAYS REQUIRES BOTH HANDS!

Rotating the Two or Three Position Switch for both the RA axis and the Dec axis requires the use of both hands to prevent sudden or unexpected rotation of the mount.

- Before rotating the Dec Axis Two or Three Position Switch with your right hand, firmly grasp the Versa-Plate with your left hand to prevent sudden rotation of this axis from an unbalanced payload.
- Before rotating the RA Axis Two or Three Position Switch with your right hand, firmly grasp the Counterweight Shaft with your left hand to prevent sudden rotation of this axis from an unbalanced payload.

When the switch is rotated to, or passes through the Balance Position, the axis will rotate freely. Unexpected rotation of either axis due to an unbalanced payload can cause personal injury or serious damage to the mount!

Always use extreme caution and, please, always use BOTH HANDS!



Track Position: Rotate the arrow on the switch fully counterclockwise to engage the worm with the gear. This position is used during normal mount operation.



Balance Position: Rotate the arrow on the switch to the center position to disengage the worm from the gear so that the axis rotates freely.



Balancing either the right ascension or declination axis of the Paramount is always a two-handed operation! Please carefully read the document shown in Figure 14 for details about where to grasp each axis before placing the Three Position Switch in the Balance Position.

This position is for balancing the payload and is the recommended position to place the switch *after* the mount has been placed inside the shipping container box and while the mount is being transported. If the mount is subjected to a severe impact during shipping, both axes will rotate freely. Unrestricted motion in each axis can help minimize damage to the worms and gears.



The Paramount must always be homed after balancing either axis! Otherwise, the mount will be “lost in space” and potentially slew beyond the software slew limits.



Lock Position (Paramount MX only): Rotate the Three Position switch fully clockwise to separate the worm from the gear *and* lock the axis in place. Always lock both axes before lifting the mount.

An axis can be locked to any position, at 5 degree increments. Note that physically rotating the switch to the Lock Position inserts an internal *locking shaft* into one of 72 *locking holes* that are machined into the internal gear. You will usually need to wiggle the axis a few degrees back and forth in order to align the locking shaft with one of the locking holes. When the shaft enters the hole, the entire Three Position Switch will drop slightly into worm gear cover. Once locked, the axis can no longer rotate.

Rotating the switch away from the Lock Position causes the locking shaft to be removed from locking hole and the axis will rotate freely. Note that the entire switch itself will rise slightly out of the worm block cover as a result.



Unlock Position (Paramount MX+ and MyT): Pull out and rotate the transportation lock knob 90 degrees **clockwise** to lock/unlock the axis. While this knob can be rotated in either direction, always rotate it clockwise as *counterclockwise rotation may cause the knob head to become loose*. Always lock both axes before lifting the mount.

Each axis can be locked at any position, in five degree increments. Note that physically rotating the switch to the Lock Position inserts an internal *locking shaft* into one of seventy two *locking holes* that are machined into the internal

gear. You will usually need to wiggle the axis a few degrees back and forth in order to align the locking shaft with one of the locking holes. When the shaft enters the locking hole, the entire transport lock knob will drop slightly into worm gear cover. The axis will not rotate when the knob is in the lock position, even if the two position switch is in the Track position.

Pulling out and rotating the knob 90 degrees allows the axis to rotate freely. Note that the entire knob will rise slightly out of the worm block cover when in the unlocked position.

RA Spring Plunger and Cam Stop Access Hole (Paramount ME II and MX+ Only)

This hole provides access to the spring plunger and cam stop adjustment. See the Paramount Cam Stop Adjustment Instructions document here:

<http://www.bisque.com/sc/media/p/75503.aspx> for details.

RA Encoder Cover (Paramount ME II Only)

This cover provides access to the absolute encoder module and is reserved for future use.

RA Assembly

The RA Assembly houses an internal shaft that can be used to snake additional cables through the mount and allows light to pass through the mount for the polar alignment telescope.

Electronics Box

The Electronics Box includes the mount power switch, USB 2.0 cable input, status lights, ports that can be used to run power through the mount to the Instrument Panel, a hardware park port and an expansion slot access panel for the WiSky Wi-Fi and absolute encoder module.

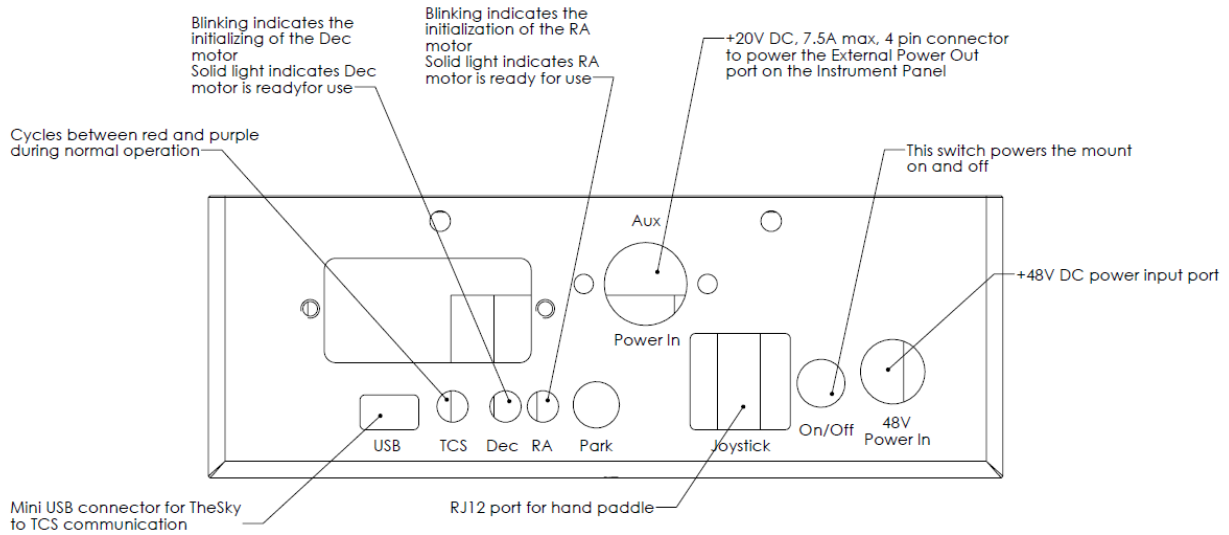

Figure 38: Technical drawing of the Paramount MX and Paramount MX+ Electronics Box labeling each component.



Figure 39: Photograph of the Paramount ME II Electronics Box.

Electronics Box Components

External Power (Power In)

This 4-pin DC power connector can be used to run up to 20V at up to 7.5 amps DC maximum power through the mount to the Instrument Panel. See “Powering Devices (Power Out)” on page 70 for specifications for this connector and the internal cabling.



The Paramount External power ports and through the mount cabling is intended to be used with direct current (DC) power sources only. Never attempt to power devices through the mount with an alternating current (AC) power source.

See page 189 for the pin out specifications and connector part numbers.



The External Power connectors on the Instrument Panel and on the Electronics Box **do not supply power** nor do they have anything to do with the Paramount power supply.

These connectors act as a conduit to route an external DC power source that is connected to External Power connector located in the Electronics Box to the External Power connector in the Instrument Panel.



Do not plug the Paramount ME II power supply into this port! See “Power Input (48V Power In)” on page 82 for instructions on how to supply power the Paramount ME II.

Mini-b USB Port (USB)

The USB port accepts USB cables with 5-pin Mini-b style connectors.

TCS Status LED (TCS)

The Telescope Control System (TCS) status light emitting diode (LED) “pulsates” from bright to faint to provide visual confirmation that the control system is operating normally. If this LED is not illuminated after turning the mount on, there may be a problem with the Bisque TCS. Please contact Software Bisque (page 15) for further troubleshooting advice.

Right Ascension and Declination LEDs (Dec and RA)

The right ascension and declination LEDs show the status of the DC-servo motors. The LEDs blink while the motors are being initialized. When the LEDs shine steadily, the motor is operating normally and ready for use. If either LED is not illuminated, motor initialization failed. An unbalanced payload, uncentered joystick, or depressed joystick button can cause motor initialization failure. Turn the power off, make sure the mount payload is properly balanced, the joystick on the hand controller is centered, and the joystick button is not pressed before repowering the mount to see if the behavior persists.

Hardware Parking (Park)

Reserved for future use. This port may offer the ability to “hardware park” the Paramount by supplying an external voltage to the port. This capability offers an alternative to parking the mount using *TheSkyX Professional Edition* and can be crucial as a backup parking method when operating the mount remotely.



Do not attempt to supply voltage to this port! Doing so can damage to the MKS 5000 control system and immediately voids the warranty.

Hand Controller or Joystick Port (Joystick)

Plug the RJ12 connector on the Paramount hand controller or the Paramount ME joystick to manually home and slew the mount. See page 111 for details about this component.

Mount Power Switch (On/Off)

This switch turns the mount on (up position) and off (down position).





Power Input (48V Power In)

This port is used to supply power to the mount’s control system. The Electronics Box’s female 48V Power In port accepts a 2.5 mm Kobiconn DC power plug with a locking collar (Mouser Electronics part number: 171-7395, <http://www.mouser.com>).

The Paramount ME II, Paramount MX, Paramount MX+ and Paramount MyT PSUs use tip positive plugs. See “Power Supply Unit” on page 115 for more information.

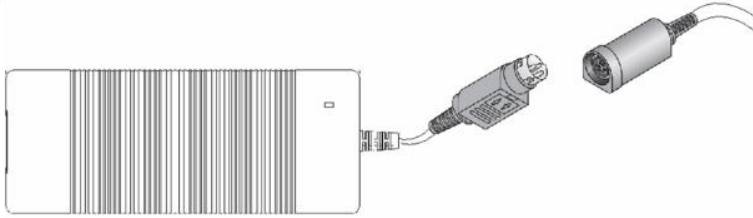
Plugging Power Supply Unit into the Electronics Box

The Paramount MX PSU can be plugged directly into the 48V Power In port on the Electronics Box; the Paramount ME II and Paramount MX+ requires an additional power extension cable. The table below describes how to physically connect the PSU of each model from the external power source to the **48V Power In** port (page 82) on the Electronics Box.

Model	Connecting PSU to 48V Power In Port	Connecting the PSU to External Power
	<ol style="list-style-type: none"> 1. Plug the 4-pin locking male Kycon connector on the PSU into the female Kycon connector on the Power Supply Extension Cable.  <p data-bbox="326 1188 1094 1215">Figure 40: Paramount ME II PSU plugs into the Power Supply Extension Cable.</p> <p data-bbox="371 1253 1099 1318"><i>Do not attempt to plug the 4-pin Kycon connector on the PSU into the Electronics Box port labeled Power In.</i></p> <ol style="list-style-type: none"> 2. Plug the male Kobiconn DC power plug on the Power Supply Extension Cable into the port labeled 48 V Power on the Electronics Box. 	<p>Plug the female end of the Power Cable for the Power Supply Unit (page 46) into the PSU’s power input. Plug the male end into an external power supply (electrical grid, battery or suitable other power source).</p>
  	<p>Plug the male Kobiconn DC power plug on the Power Supply Extension Cable into the port labeled 48V Power on the Electronics Box.</p>	<p>Plug the female end of the Power Cable for the Power Supply Unit (page 46) into the PSU’s power input. Plug the male end into an external power supply.</p>

Expansion Slot Cover

The removable cover on the front of the Electronics Box provides access to a plug in “expansion slot” on the MKS 5000 electronics board. This expansion slot may be used to provide future control system enhancements. For now, there is no reason to remove this cover.

Polar Alignment Scope Mounting

The Paramount ME II, Paramount MX and Paramount MX+ can be fitted with an optional polar alignment scope to optically align the mount’s polar axis with the celestial pole. The Paramount Polar Alignment Scope includes the optics, a reticle illuminator, an extension tube, a threaded machined aluminum cover that protects the scope during transit and a mounting bracket that provides space for custom through the mount cabling to exit the mount.

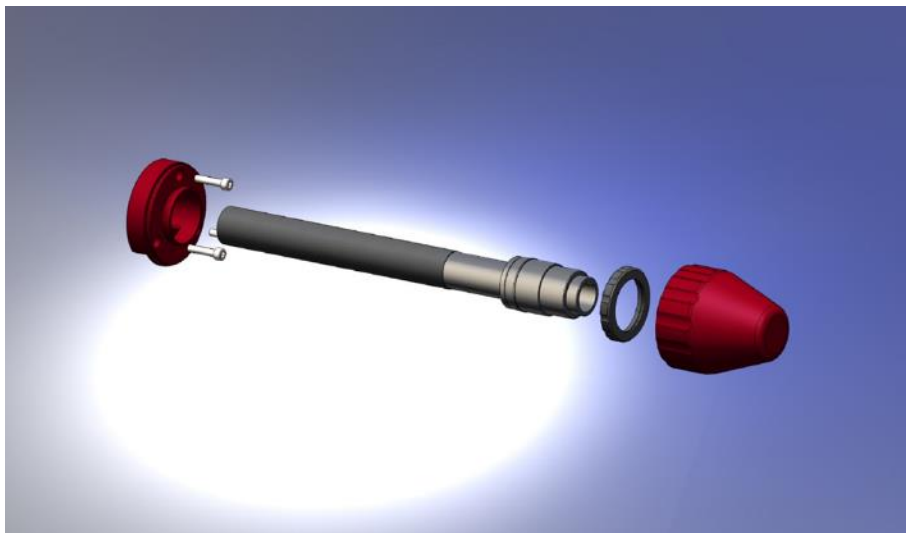

Figure 41: Polar Alignment Scope and mounting hardware.

Download the PDF document named “Paramount Polar Alignment Scope Installation and Use” from the Software Bisque Downloads page for more information:

<http://www.bisque.com/sc/media/p/58136.aspx>

Type the URL below into your web browser’s **Address** bar to purchase the Paramount Polar Scope:

<http://www.bisque.com/sc/shops/store/MXPolarScope.aspx>

Polar Axis Adjustments

A common problem with many commercial mounts when making polar alignment adjustments is that changes to the position of the altitude axis also changes the position of the azimuth axis, and vice-versa.

In other words, the basic mechanical design is flawed in that it prevents independent motion in azimuth and altitude. This makes precise polar alignment more difficult than it should be.

The Paramount base consists of an outer, fixed plate that is mounted to the pier, and an inner rotating plate on which the mount sits. Adjustments in azimuth are achieved by rotating the Azimuth Adjustment Knobs at the front of the mount (Figure 42). For a level mount, rotation of this plate does not affect the altitude of the polar axis.

The altitude axis is held in place using a separate mechanical system that includes the Altitude Adjuster Thrust Knobs (Figure 59) and the Altitude Adjuster (Figure 44). For a level mount, adjustments in altitude will not change the azimuth of the polar axis.

Azimuth Adjuster Knobs

The base of the Paramount incorporates a circular plate inside the mount's rectangular base, and allows the mount to rotate about a vertical axis through the center of the mount. This rotation permits the azimuth of the polar axis to be changed when aligning the mount to the celestial pole. The Azimuth Adjustment Knobs push against a bar that is mounted to the circular plate and provide the means to rotate the plate, even when the mount is fully loaded.

The Azimuth Adjustment Knobs work in *opposition* – one must be loosened before the other can be tightened. The knob that is tightened rotates the azimuth axis; the knob that is loosened provides “clearance” for the axis to rotate.

Provided the opposite knob is sufficiently loose, the azimuth axis can be rotated by tightening the opposite knob, without applying excessive force. Note that a fully-loaded mount may make rotating the base plate, and the knobs, more difficult. If necessary, insert a 5/32 hex wrench into the center of the adjustment knob to assist rotation. For really heavy loads,

- Tightening the right knob moves azimuth east.
- Tightening the left knob moves azimuth west.

Before making any adjustments to the azimuth of the polar axis:

- Make sure the rotating plate is close to its center position so there is a maximum amount of rotation in both directions.
- Rotate both knobs counterclockwise until both are just tight. This effectively squeezes the rotating bar and serves as a good zero point. To avoid deforming the rotating bar, do not over-tighten the knobs.
- When making adjustments based on the advice given in the TPoint Add On Polar Alignment Report, first loosen the knob on the opposite side of the direction of rotation the suggested number of tics, then tighten the other knob until it is “just tight” again.

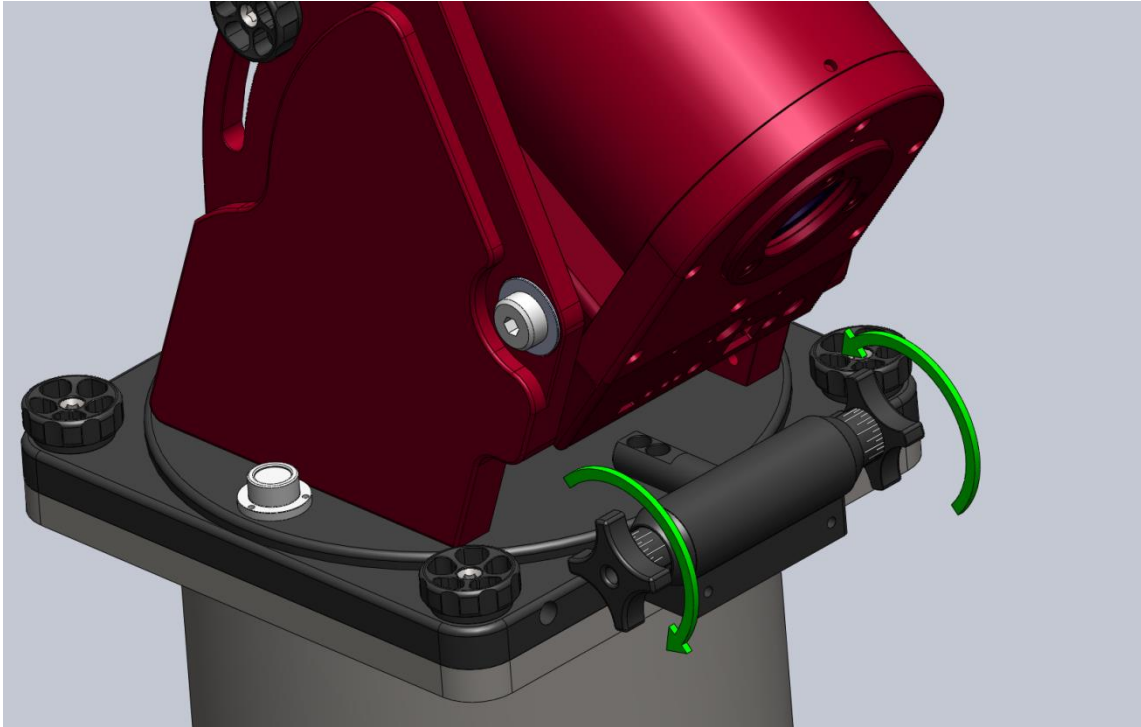

Figure 42: Rotate the Azimuth Adjuster Knobs to adjust the azimuth axis (Paramount MX pictured above).

Azimuth Vernier Scale

Both Azimuth Adjuster Knobs include Vernier scales that can be used for refining the position of the azimuth axis. The longest tic marks represent *approximately* 4 arcminutes rotation in azimuth. The medium length marks are *approximately* 2 arcminutes rotation and the shortest tic marks are *approximately* 1 arcminute.

So, for example, if the *TPoint Add On's* Polar Alignment Report suggests to “rotate the azimuth axis 180 arcseconds east,” you would have to rotate the right knob clockwise three tics (about three arcminutes) on the Vernier scale.



The azimuth axis polar axis adjustment range is plus or minus seven (7) degrees from center position. To be safe, make sure to orient your permanent pier within three (3) degrees (or so) of the celestial pole so that polar alignment can be achieved without having to rotate the permanently mounted pier itself.

- Software Bisque Permanent piers have slotted mounting holes that provide additional azimuth rotation (plus or minus five degrees from the center position).
- The Software Bisque Pyramid Portable Pier and the Might Tripod allow unlimited rotation in azimuth, so the mount's initial orientation does not matter.

Base Thrust Mounting Knobs

The four base thrust mounting knobs are used to securely attach the base of the Paramount to the top of the pier, tripod or other mounting surface.



Always secure the Paramount to a pier or tripod *before* attaching the counterweight shaft, adding counterweights, or optical equipment! Forgetting to do so is relatively easy, and can have disastrous results.

Model	Total Length	Thread Specification
MEII	5 cm (2 in.)	3/8-inch, 24 threads per inch UNF
MX MX+	3.8 cm (1.5 in.)	3/8-inch, 24 threads per inch UNF
MYT	3.8 cm (1.5 in.)	3/8-inch, 24 threads per inch UNF

The Paramount ME II base plate also includes integrated micro levelers than can help level the Base Plate on a slightly uneven mounting surfaces. Please carefully read “Micro Levelers (Paramount ME II Only)” on page 111 for details about using this component.

Base Plate

The base plate incorporates four precision thrust mounting knobs that are used to attach the Paramount mount to top of the pier or tripod.



There are two set screws located on the side of the Base Plate that compress a Delrin plunger against the side of the integrated rotating plate and prevent lateral motion of the plate.

These set screws should normally never be adjusted unless instructed to do so by a Software Bisque technician.

The set screw access holes on the Paramount MX, Paramount MX+ and Paramount MYT are located on the *same side* of the Base Plate as the Altitude Adjuster Knobs. (One is shown to the left of the Azimuth Adjuster Knob in Figure 42.). On the Paramount ME II, they are located on the opposite side of the Altitude Adjuster Knobs.

Paramount ME II Rear View

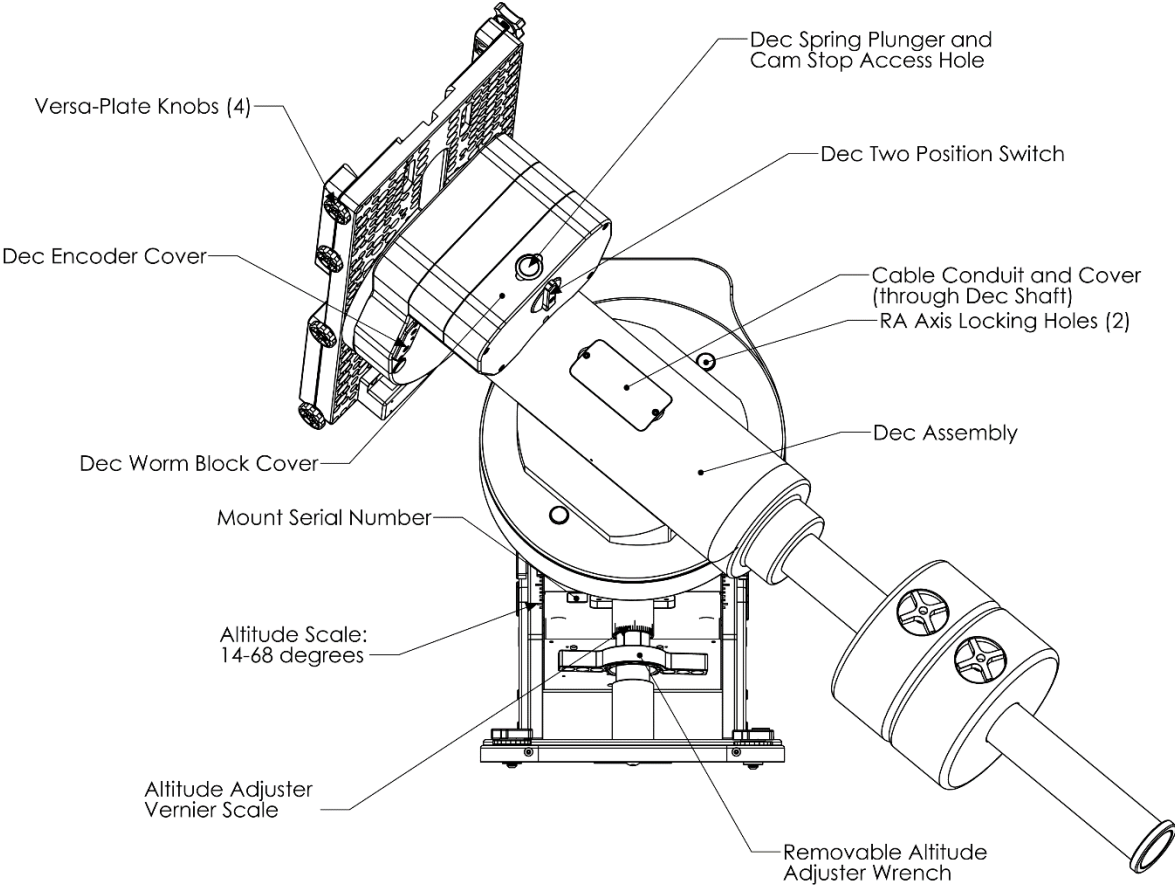

Figure 43: The rear view of the Paramount ME II.

Paramount MX Rear View

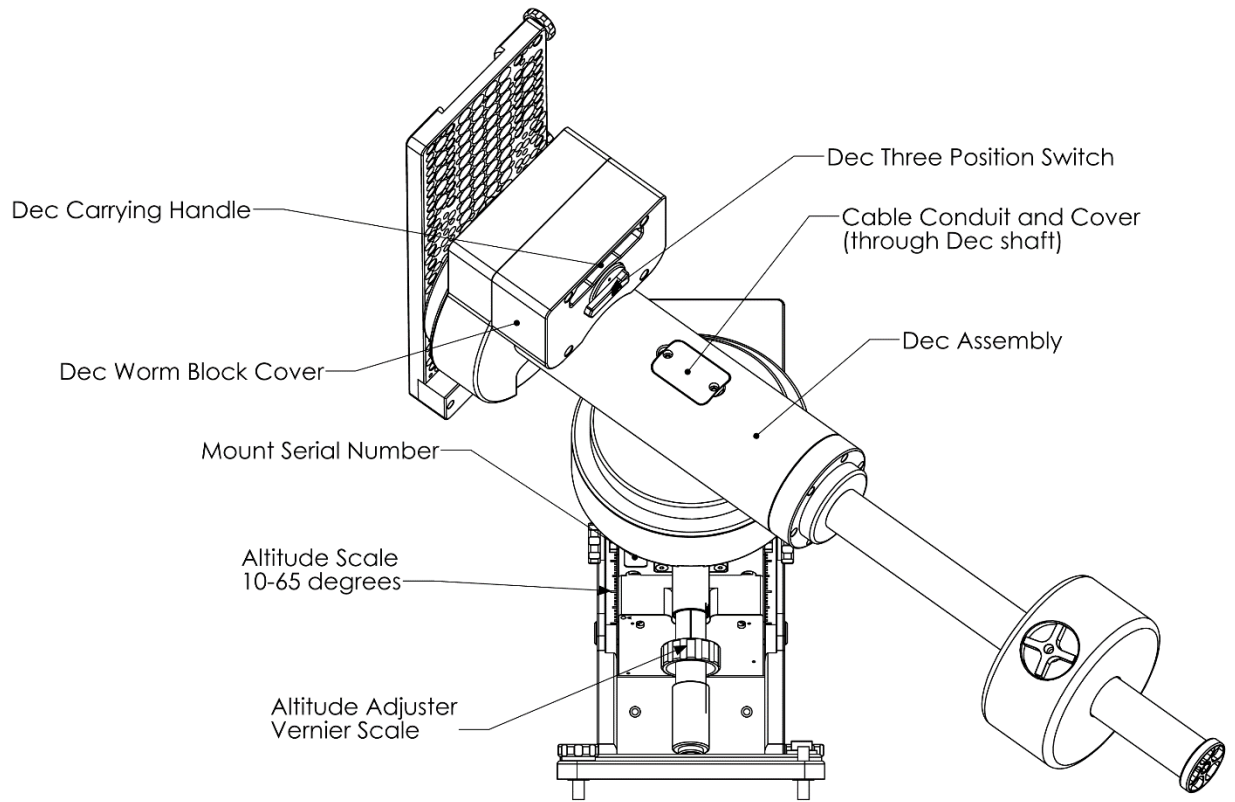

Figure 44: The rear view of the Paramount MX.

Paramount MX+ Rear View

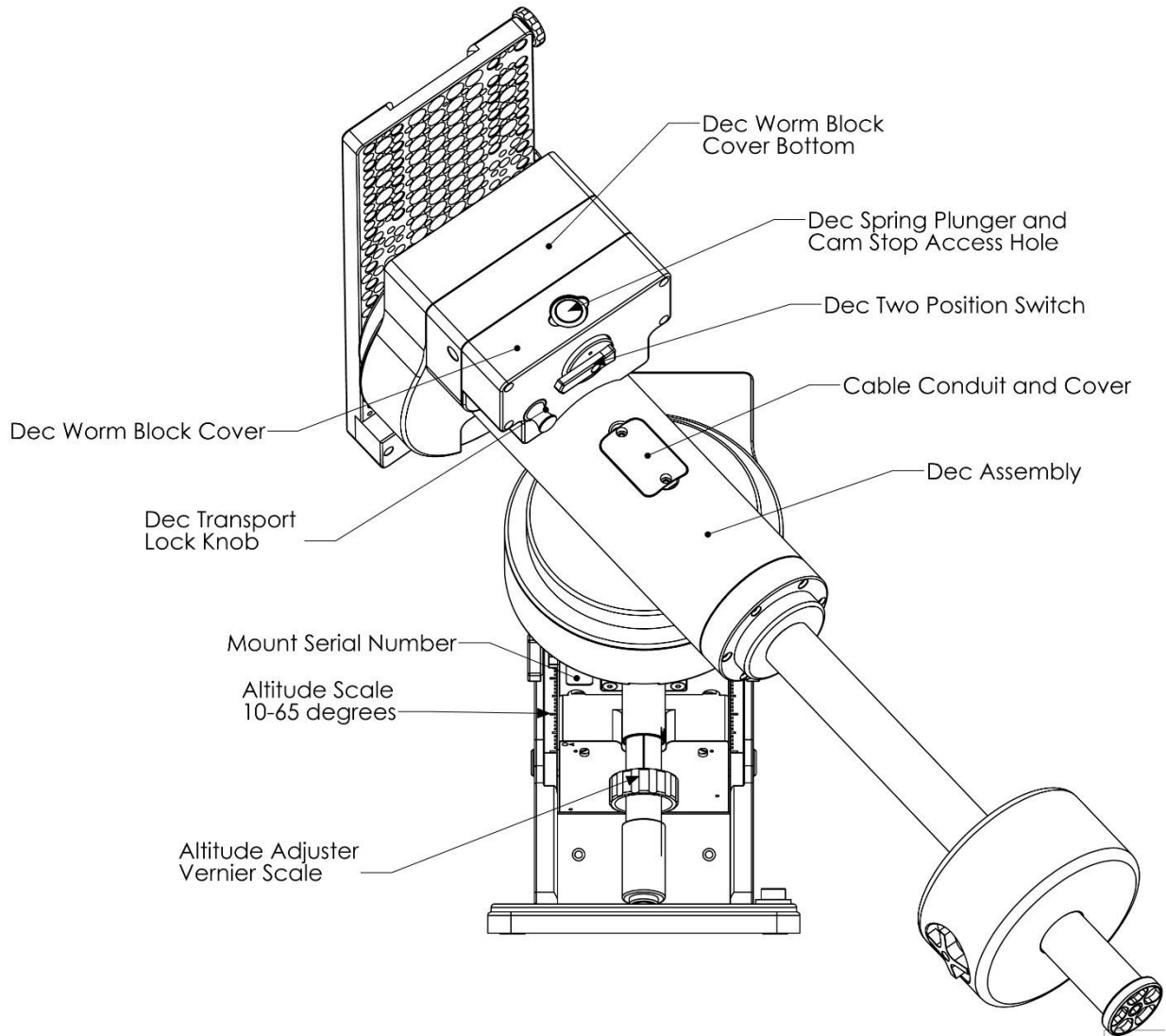

Figure 45: The rear view of the Paramount MX+.

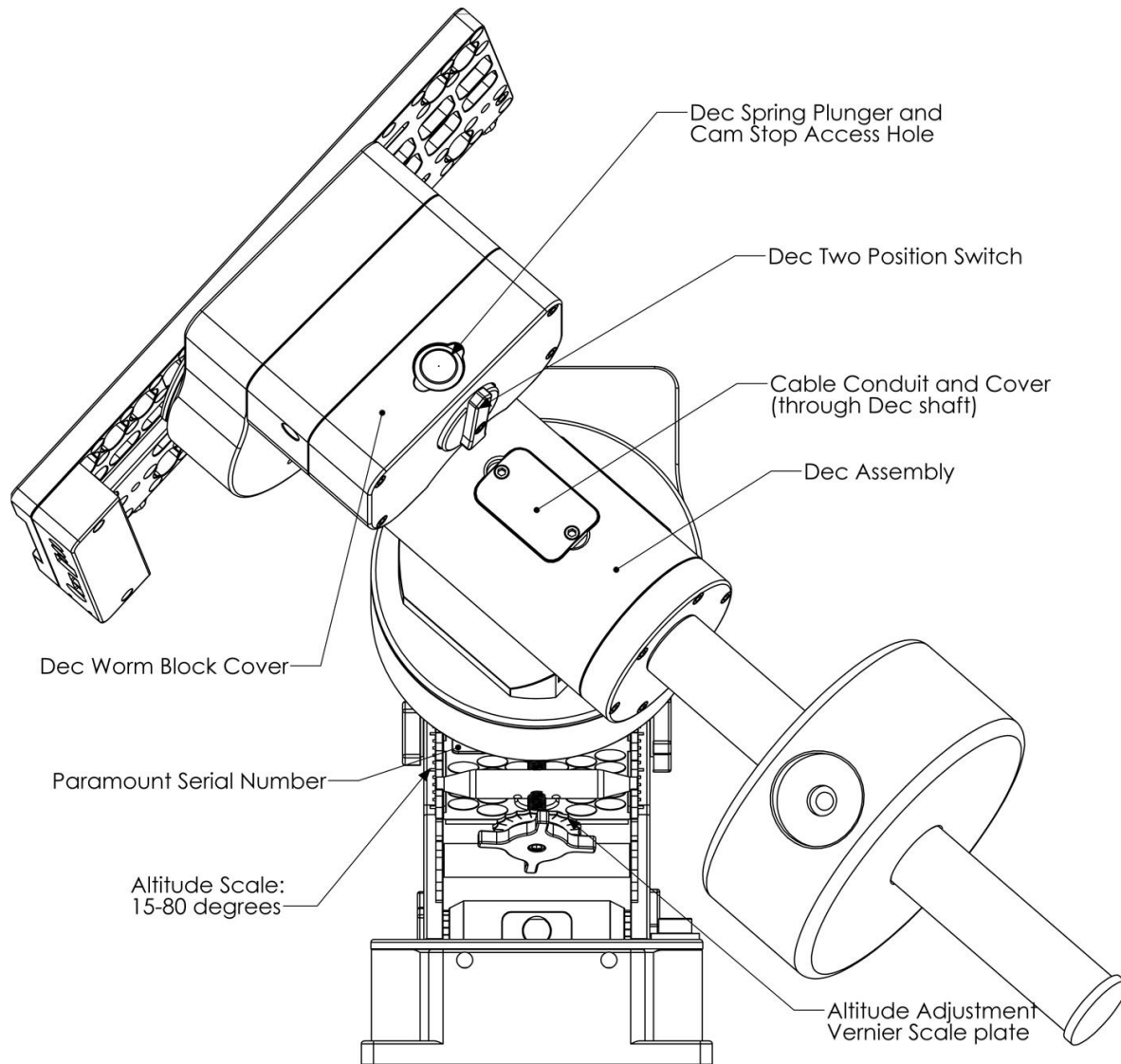

Figure 46: The rear view of the Paramount MyT.

Declination Carrying Handle (Paramount MX Only)

Use the integrated carrying handle (located above the Declination Three Position Switch) to lift the mount. Remember to always place both Three Position Switches in the Lock position before lifting the mount (page 74).

Declination Axis Three Position Switch (Paramount MX Dec Three Position Switch)

See the “RA Worm Block Switch” description on page 74 for details about using this component.

Cable Conduit Access Hole and Cover

The Paramount MX and Paramount MX+ (only) can accept an optional polar alignment scope. “Line of site” for the polar alignment scope is achieved by removing the Cable Conduit Cover and rotating the

declination axis until the through holes in the internal shaft allow incoming light to pass through the mount.

Early models of the Paramount MX used a circular aluminum nut instead of a curved aluminum plate to cover the declination axis access hole, as shown in Figure 47.

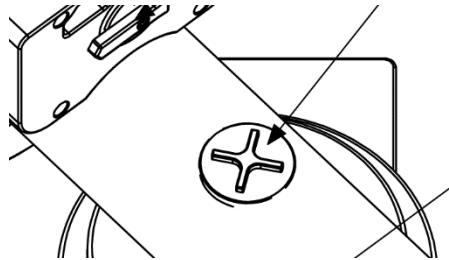

Figure 47: The original Paramount MX cable conduit access cover.



Always keep fingers clear from the cable conduit access hole!

- While the declination axis rotates during mount slews, an internal shaft in the declination assembly is also being rotated by a very high torque servomotor.
- When the declination axis' Three Position Switch is in the Balance Position (page 74), the internal shaft can rotate freely and may do so with a high angular velocity when the mount's payload is even slightly out of balance.

In both cases, the rotating internal shaft creates a potentially dangerous pinch point with the outer declination axis assembly that can cut, crush or sever fingers.

Always keep fingers clear during mount slews and use extreme caution when routing cables through the mount, or aligning the declination shaft's "through-hole" during polar scope alignment.

Right Ascension Axis Locking Hole (Paramount ME II Only)

The Paramount ME II's right ascension axis can be locked into one, and only one, position by orienting the counterweight shaft vertically and then inserting two shoulder bolts (supplied with mount) into both Right Ascension Axis Locking Holes and through the right ascension gear. The bolts can be permanently mounted (before shipment, for example) by threading a nut on end of the bolt that protrudes through the back side of right ascension gear housing.

The reason the right ascension axis can only be locked when the counterweight shaft is vertical is to prevent unbalanced payloads from damaging the mount. If the mount's right ascension axis were to be locked in any other orientation, unbalanced payload could potentially exert destructive torque on the locking mechanism.



When installed, the right ascension and declination axis locking bolts are designed to prevent the axis from rotating during shipment or while adding payload to the mount.

As a best practice, always try to maintain a relatively balanced payload, even when mounting equipment.

The shoulder bolts are not designed to carry the mount's entire payload. If you mount an excessively unbalanced payload on the declination axis, for example, you run the risk of bending one or both of the bolts, making removal difficult.

The specifications for right ascension axis locking shoulder bolt are:

- 18-8 stainless steel shoulder screw
- 5/16-in. shoulder diameter
- 2-1/4-in. long shoulder
- 1/4 in.–20 threads per inch

The declination axis locking shoulder bolt has the same specifications, but is 1 3/4-in. long.

Configurable Hard Stop Positions (Paramount ME II Only)

The Right Ascension Locking Holes also provide access bolts that define the Paramount ME's configurable hard stop position. For each "side of the meridian", there are six different positions where a physical hard stop mounting bolt can be installed.

After placing the Two Position Switch in the Balance mode, rotate the right ascension access and look into one of the Right Ascension Locking Holes. As the axis is rotated, you will see five threaded holes that do not contain a bolt and the sixth, at the maximum hard stop limit, with a bolt installed. The position of this bolt defines the maximum allowable rotation for the axis in this direction.

Normally, the hard stop position need not be altered, and the configurable software slew limits (page 167) are used to prevent the mount from slewing to undesired positions.

To change the position of the hard stop, remove the hard stop bolt using a square-ended hex wrench. A square-ended hex wrench bolt captivates the socket head cap screw so that it can be extracted from the Right Ascension Locking Hole. Once removed, the socket head cap screw can be placed at the desired hard stop position.

Declination Axis Assembly (Dec Assembly)

The declination assembly is a permanent component of the Paramount and cannot be removed.

Paramount Serial Number (Serial Number)

The Paramount's serial number is permanently affixed to the base of the right ascension assembly. It also appears on your invoice or packing slip (page 48).

Altitude Scale

The Altitude Scale is a series of tic marks machined into the edge of both altitude wedge plates. On the Paramount MEII, MX, and MX+, the longer tic marks represent *approximately* ten degree increments, the medium tics are *approximately* five degree increments and the shorter tics are *approximately* one degree increments. The short tic marks on the Paramount MyT altitude scale represent approximately two degrees in elevation; longer tic marks represent ten degree increments.

When the mount's base is close to level, this scale can be used to set the altitude of the polar axis to plus or minus fifteen arcminutes or so.

The altitude of the mount's polar axis can be determined by looking at the intersection of the bottom of the altitude reference block and the nearest tic mark on the Altitude Scale (Paramount MEII, MX, and MX+, Figure 49), or the machined arrow on the base of the Paramount MyT right ascension housing Figure 50.

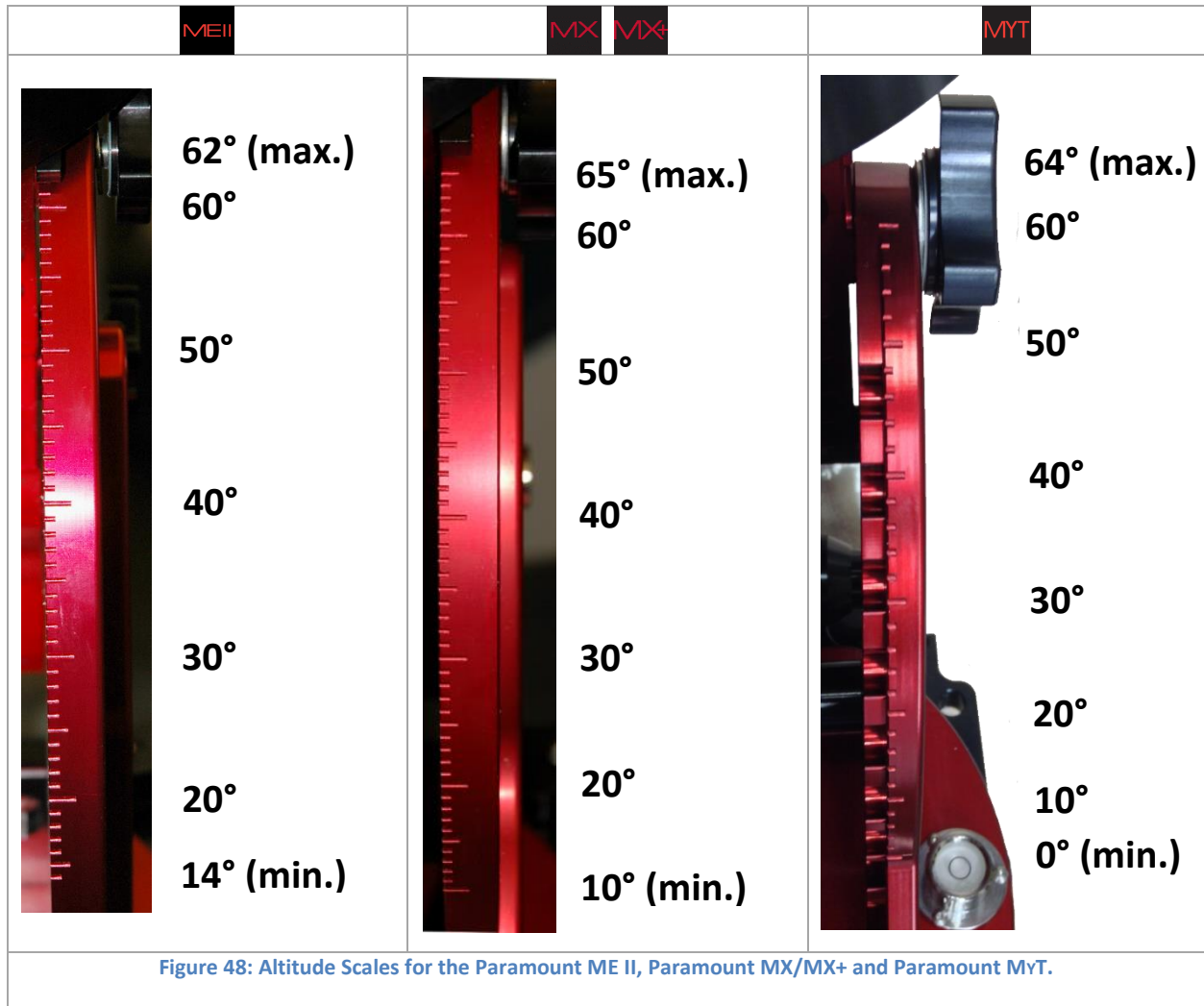

Model	Minimum Elevation (°)	Maximum Elevation (°)
MEII	14	62
MX	10	65*
MX+	10	65*
MYT	0	64

**The Paramount MX and Paramount MX+ polar axis can actually be adjusted to exceed the maximum scale by about one degree, so that the highest “reachable” latitude is closer to 66 degrees.*

An optional Paramount ME II or Paramount MX/MX+ *Latitude Adjustment Wedge* allows the mount’s polar axis to reach lower or higher polar elevations.

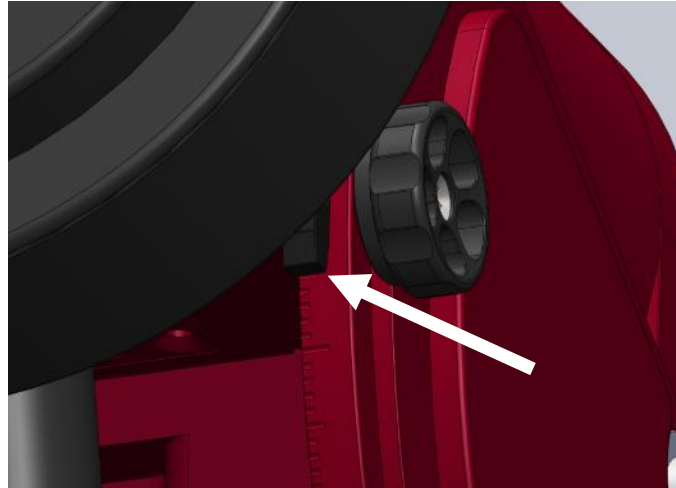

Figure 49: The tic mark that is aligned with the bottom of the Altitude Reference Block represents the polar axis altitude for the Paramount ME II, Paramount MX and Paramount MX+.

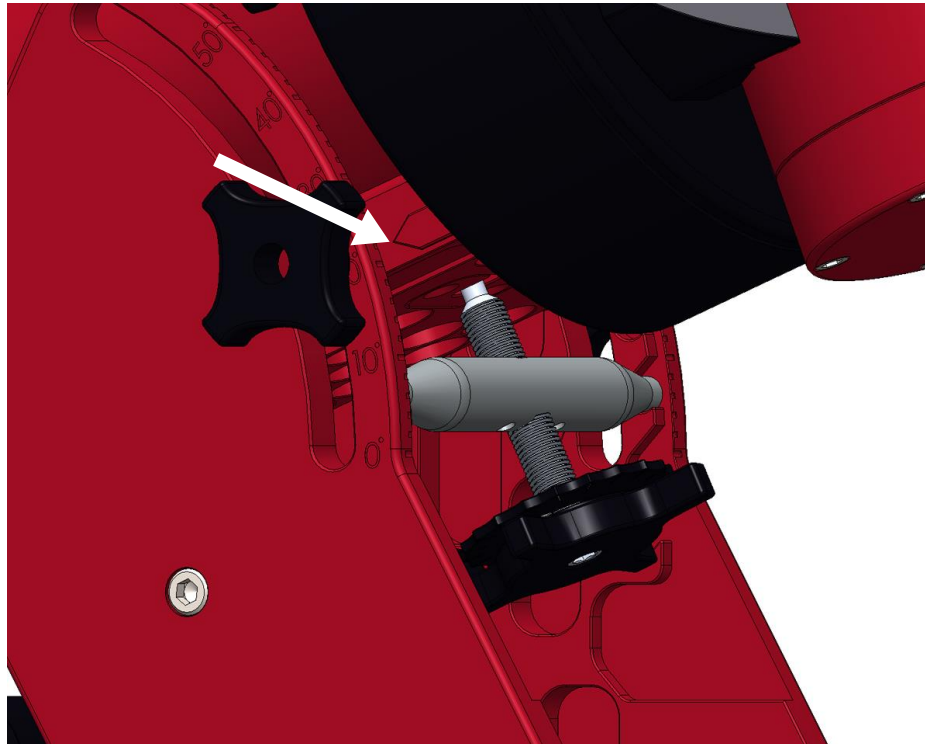

Figure 50: The arrow machined into the right ascension base plate points to the altitude of Paramount MyT polar axis.

Altitude Adjuster

The Altitude Adjuster is used to make precise adjustments to the mount's altitude axis during polar alignment. The elevation of this axis should match the *latitude* of your observing site. The adjuster uses right-handed threads so that, when viewed from above, rotating the Altitude Adjuster knob counterclockwise raises the elevation of the polar axis.



Remember the “Right Hand” Rule

The altitude adjuster uses “right-handed” threads. Suppose you wish to increase the altitude of the polar axis. Point the thumb on your right hand upward, and rotate the altitude adjuster in the direction your fingers curl.

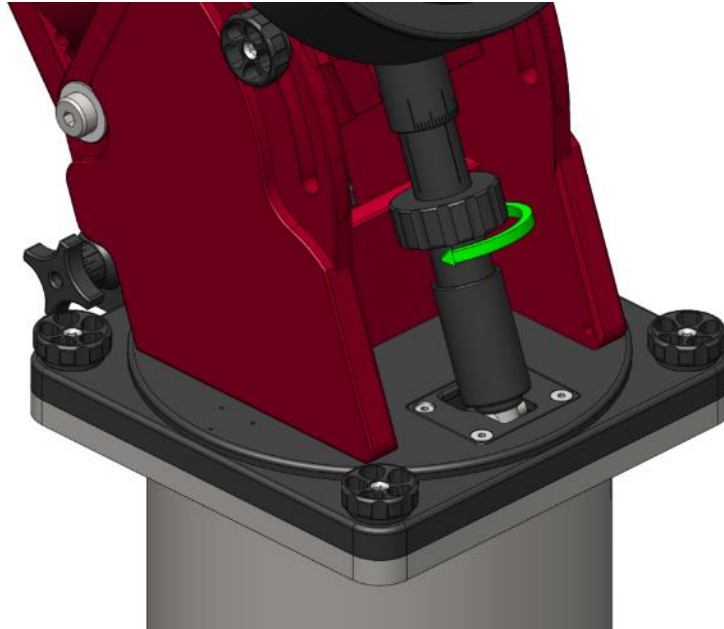

Figure 51: Rotating the Altitude Adjuster in the direction of the arrow lowers the MX axis (right hand rule applies).

Polar Axis Adjustment for the Paramount MX, Paramount MX+ and Paramount ME II

1. Loosen the Altitude Adjuster Thrust Knobs (page 109).
2. Rotate the large central knob (near the arrow in Figure 51) to raise or lower the polar axis.

The Paramount ME II includes a removable Altitude Adjuster Wrench (page 115) to help rotate the Altitude Adjuster Knob, even with the heavy payloads.

Polar Axis Adjustment for the Paramount MyT

The Paramount MyT has coarse and fine altitude adjustments and requires a *two-step process* when setting the polar axis altitude.

The coarse adjustment mechanism incorporates a horizontal bar that can be placed into slots that are machined on the inside of the wedge plates. Each slot raises or lowers the polar altitude by eight degrees. The coarse adjustment should be performed *before* any equipment is attached to the Versa-Plate.

Once the polar axis has been placed at the approximate latitude using the coarse adjustment, the fine adjustment can be used to refine the polar axis altitude when the mount is loaded with equipment and counterweights.

Adjusting the Paramount MyT Polar Axis:

1. Rotate the fine altitude adjustment knob until the stainless steel bar is centered in the threaded rod (Figure 52). Doing so ensures there is sufficient fine adjustment to achieve polar alignment at a given coarse adjustment position (described below). If the bar is not centered in the threads initially, there may not be enough travel to reach the desired altitude. If you run out of travel when making fine adjustments, re-center the bar in the threads, then move the altitude higher or lower using the coarse alignment, as necessary.
2. Loosen (but do not remove) both Altitude Retaining Knobs on the wedge side plate of the mount, then lift the right ascension axis. This will unseat the bar from the slots on the inside of the wedge plate and allow the entire mechanism to swing freely (Figure 53).
3. Align the arrow that is machined either side of the right ascension housing base (Figure 50) with the tic mark that matches the observing site's latitude, and then insert the stainless steel bar into the nearest slot.

The threads on the fine adjustment mechanism allow the altitude of the polar axis to be moved up or down 8 degrees from the center position. Once the bar is at the coarse position, there should be ample "overlap" to get to the desired altitude.

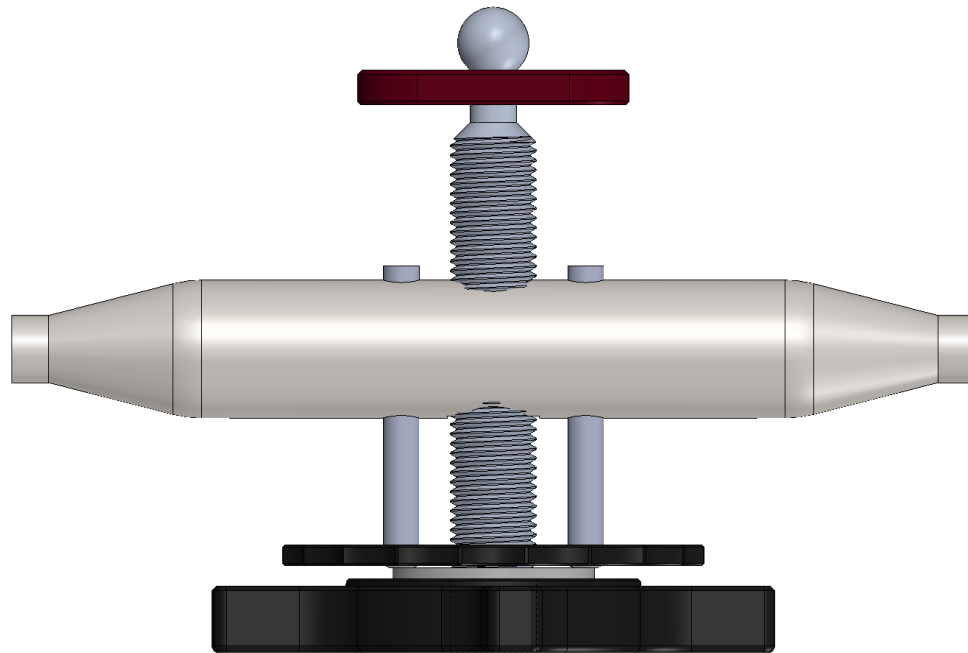

Figure 52: The Paramount MyT fine altitude adjustment assembly at the *mid-travel* position.



Figure 53: The Paramount MyT coarse altitude adjustment mechanism when lifted out of a mounting slot.

From here, you can mount your equipment and get ready to precisely align the mount with the refracted pole. See “How to Polar Align” on page 114 for details.

Altitude Adjuster Vernier Scale

Paramount ME II, Paramount MX and Paramount MX+ Altitude Scale

In addition to the Altitude Scale tic marks on the wedge, the Altitude Adjuster knob has a fine-position Vernier scale that allows the mount’s elevation to be adjusted to an accuracy of plus or minus 15 arcseconds (Figure 54).

So, for example, when the *TPoint Add On’s* Polar Alignment Report states “raise the mount’s polar axis 62 arcminutes,” it means that one complete revolution of the Altitude Adjuster, plus two positive tic marks on the Vernier scale from the vertical line labeled ‘A’ should place the elevation of the mount close to the refracted pole.

The arrow on Figure 54 shows the location of the fine-position Vernier scale for the Paramount MX, Paramount MX+ and Paramount ME II. This scale shows elevation adjustments from approximately +10 to –10 arcminutes. The medium height tick marks represent approximately 5 arcminute divisions; the small tic marks represent approximately 1 arcminute divisions.

One rotation of the Altitude Adjuster knob is about one degree of elevation adjustment. The rotating knob directly beneath the Vernier scale has four vertical lines labeled with the letters A, B, C, and D that

can be used to make absolute elevation adjustments. These vertical lines are 90 degrees apart and represent fifteen arcminute increments in elevation.

The Vernier scale also allows the mount's elevation to be placed at a specific position and is useful for restoring a specific elevation if the mount is used at multiple observing sites. For example, suppose your observatory's elevation is 39 degrees plus "an additional rotation that aligns the vertical B line with the – 4.5 tic mark on the Vernier scale". You can subsequently use this position to precisely restore the altitude of the polar axis each time the mount is setup.

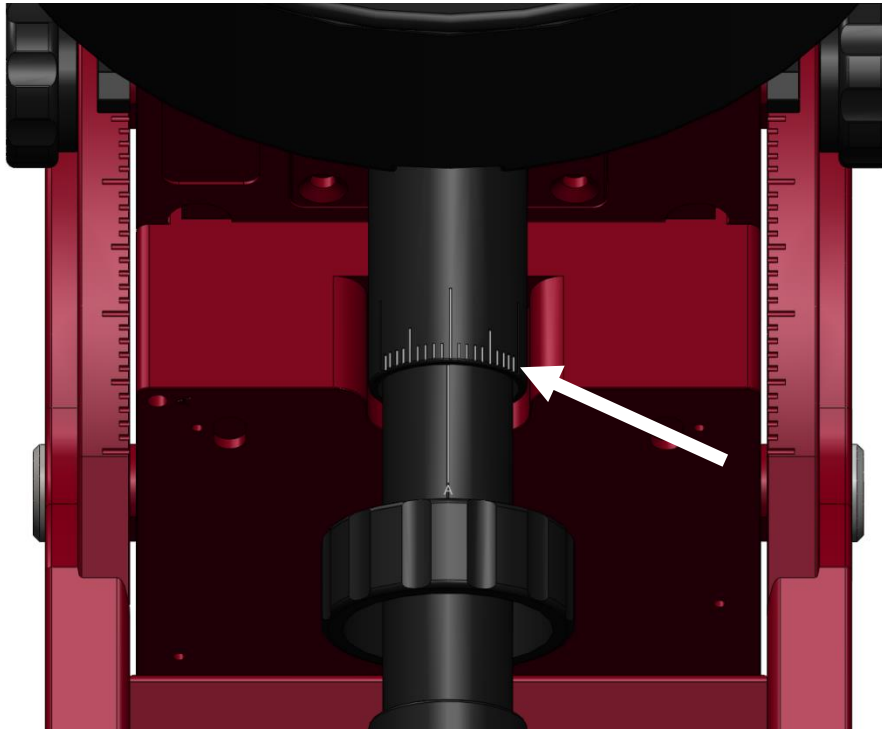

Figure 54: The Vernier scale on the Altitude Adjuster for Paramount MX, MX+ and ME II.

Paramount MyT Altitude Scale

Figure 55 shows the location of the calibrated tic marks on the Paramount MyT. Each tic on the flat, stationary plate represents an adjustment of approximately 2 arcminutes. Align the edge of the knob with the tic mark when making fine adjustments.

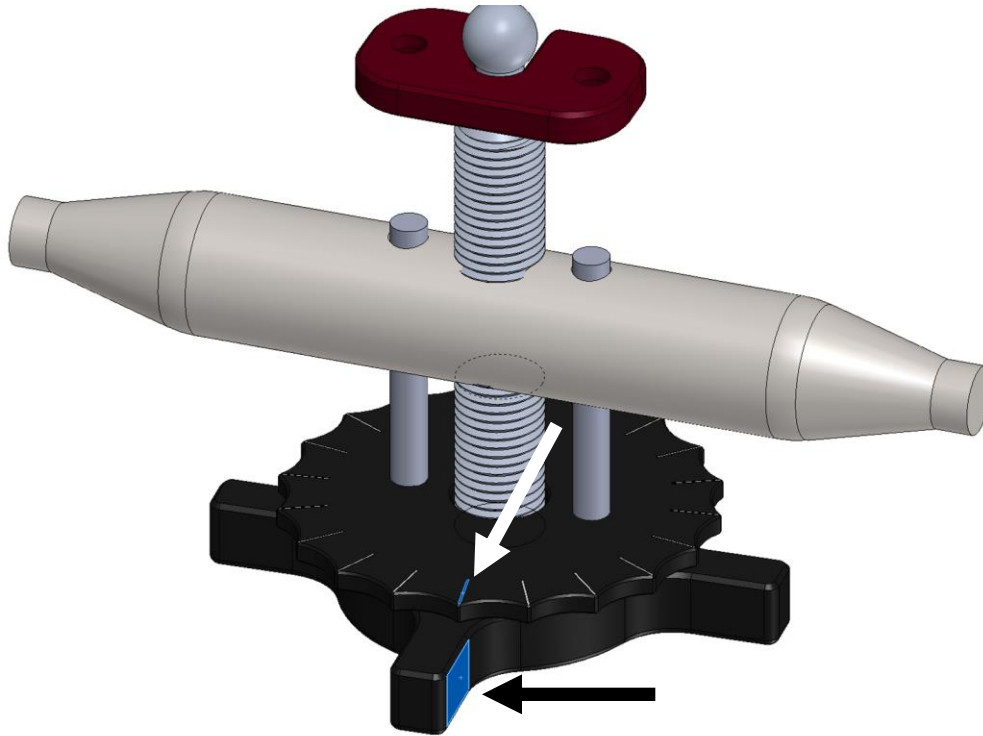





Figure 55: When making fine adjustments, align the edge of the knob with the stationary tic mark to determine relative motion.

Counterweight Shaft

To attach the stainless steel counterweight shaft to the Paramount, insert the threaded end into the bottom of the declination assembly (Figure 44) and rotate the shaft clockwise until it is hand tight. The counterweight shaft changes the mount’s center of mass and may make the unit “top heavy,” so make sure to install the secure the mount to the pier or tripod first.



Model	Length	Diameter	Weight	Maximum Number of Counterweights
	47 cm (18.5 in.)	4.763 cm (1.875 in.)	6.7 kg (14.75 lb.)	Six 30 lb. or six 40 lb.
	41 cm (16 in.)	3.8 cm (1.5 in.)	4 kg (9 lb.)	Six 20 lb.
	33 cm (13 in.)	3.8 cm (1.5 in.)	3.2 kg (7 lb.)	Four 20 lb. or 10 lb.



Always attach the counterweight shaft is attached **before operating the mount**. The weight of the counterweight shaft helps balance the unloaded right ascension axis. Attempting to slew the mount when either axis is severely out of balance may cause the motors to stall and the control system will emit successive beeps.

Counterweight Shaft Extension Bar (Optional)



The optional counterweight shaft extension bar (sold separately) screws into the end of the Paramount standard counterweight shaft. This bar both extends the moment arm and allows up to two additional counterweights for ultra-heavy payloads.

Model	Counterweight Shaft Extension Bar Specifications
	<p>1.875 in. diameter, 9.7 in. long.</p> <p>Technical drawing URL: http://www.bisque.com/sc/media/p/74385.aspx</p> <p><i>In addition to the 1.875-in. diameter counterweight shaft, the Paramount ME II can also accept the 1.5-in. diameter Paramount ME/MX counterweight shaft.</i></p>
	<p>1.5 in. diameter, 7 in. long.</p> <p>Technical drawing URL: http://www.bisque.com/sc/media/p/47380.aspx</p>

Counterweights

One counterweight is included with the Paramount MYT; two counterweights are included with the Paramount ME II, and MX. These can be mounted on the counterweight shaft to balance the mount's payload. Slide the counterweight to the approximate balance position, and then rotate the counterweight knob until the knob is hand tight. A softer metal brass plunger on the end of the knob holds the counterweight in place and should not score or gouge the stainless steel shaft.

The table below shows the counterweight specifications by model.

Model	Counterweight Specifications	Quantity Included
	<p>14 kg (30 lb.), 1.875 in. bore</p> <p>Counterweight shaft technical drawing URL: http://www.bisque.com/sc/media/p/74654.aspx</p> <p><i>In addition to the 1.875-in. diameter counterweight shaft, the Paramount ME II can also accept the 1.5-in. diameter Paramount ME/MX counterweight shaft.</i></p>	2
	<p>9 kg (20 lb.), 1.5 in. bore</p> <p>Counterweight shaft technical drawing URL: http://www.bisque.com/sc/media/p/70864.aspx</p>	2
	<p>9 kg (20 lb.), 1.5 in. bore</p>	1

The amount of counterweight required to achieve balance depends on the total weight of the optical tube assembly and accessories, and how the weight is distributed. Before adding any counterweights to the counterweight shaft, first estimate how much counterweight is required, and then add this amount to the counterweight shaft. Err on the heavy side. The counterweights should *initially* “outweigh” the optical tube assembly by being too far down the shaft. This way, when fine-tuning the balance, the counterweight shaft will tend to rotate so that the counterweights are downward, instead of your expensive equipment.

Once sufficient counterweights are added, the right ascension axis should be very “bottom heavy.” At this point, adding the optical tube assembly should result in a system that is somewhat close to being balanced.



Counterweights are extremely heavy! Please use extreme caution so that you do not accidentally drop one and injure yourself or others!

After the counterweights are added, firmly tighten each of the counterweight knobs to ensure they do not slip. Also, make sure to install the counterweight safety knob on the bottom of the counterweight shaft.



Figure 56: Please, *never ever* place any model Paramount mount in this orientation, not even with a single counterweight.



Never position the Paramount in the above orientation, with or without counterweights!

Figure 56 shows the Paramount in an *unstable* configuration that places extreme and potentially destructive lateral force on the teeth of the right ascension worm and gear. The

counterweight shaft should always remain in the vertical position while the Paramount is being loaded with counterweights and payload (telescope, camera, etc.).

If you must orient the mount's payload in a severely out of balance position, for the Paramount MX, place the Three Position Switch in the Lock position first (page 74), for the Paramount ME II install the locking bolts and place the Two Position Switch to balance, and for the Paramount MX+ place the Two Position Switch to balance and pull and rotate the transport lock knob 90 degrees to a lock position.

Even when mount's axis is locked, the excessive imbalance demonstrated above could bend, mar or otherwise damage the shaft or bolts that lock the axis in place. Please do not abuse your precision mount in this manner.



Figure 57: The Paramounts in their “happy place” with the counterweight shaft oriented vertically.

Payload Imbalance Cause and Effect

When the counterweight shaft is oriented “non-vertically” *and* one or more counterweights are on the counterweight shaft, *and* the right ascension axis is in the Track position, the extreme lateral force placed on the worm and gear forces them to separate. At this point, the right ascension axis rotates to a “balanced” position, and you will hear a chattering noise caused by the teeth of the precision gear bouncing past the teeth of the precision worm gear.

Despite the gut wrenching feeling this sound brings on, damage to the worm and gear is usually minimal. The recommended procedure is to exercise the mount (page 164) and to please try not to make this a habit.

Balancing the Payload

After attaching the counterweights, mount your optical tube assembly, camera, and all other equipment (focuser, filter wheel, field rotator, dew heater, etc.) to the Versa-Plate, then begin balancing each axis, starting with right ascension. The Paramount operates best when the payload is properly balanced, which means that, when the worm and gear are separated for a given axis, the axis does not tend to rotate in either direction. An unbalanced payload can cause numerous problems, such as stalling or “gear chattering” during slews.

By design, there is no clutching mechanism on the Paramount. To achieve balance, you must disengage the worm from the gear. When balancing the right ascension axis, orient the counterweight shaft

vertically, then slide the counterweights up or down on the counterweight shaft to change the balance point.



Always use extreme care when balancing the telescope!

- ***Make note of the weight distribution on the telescope before placing the mount's mechanical switch in the Balance position.***
- ***Always firmly grasp the OTA or counterweight shaft so that you can maintain control of the telescope.***

To balance the right ascension axis, slide the counterweights up or down the counterweight shaft until the system has no tendency to rotate in either direction. To balance the declination axis, slide the OTA forward or backward.

If you routinely swap cameras or other components, the difference in weight might be enough to cause slewing problems. In this situation, you can rebalance the system by marking the positions of counterweights on the counterweight shaft for each configuration.

Counterweight Safety Knob

The counterweight safety knob screws into the threaded hole on the end of the counterweight shaft. Always attach the counterweight safety knob immediately after adding counterweights to prevent an improperly mounted counterweight from sliding off the end of the shaft.

Paramount ME II Side View

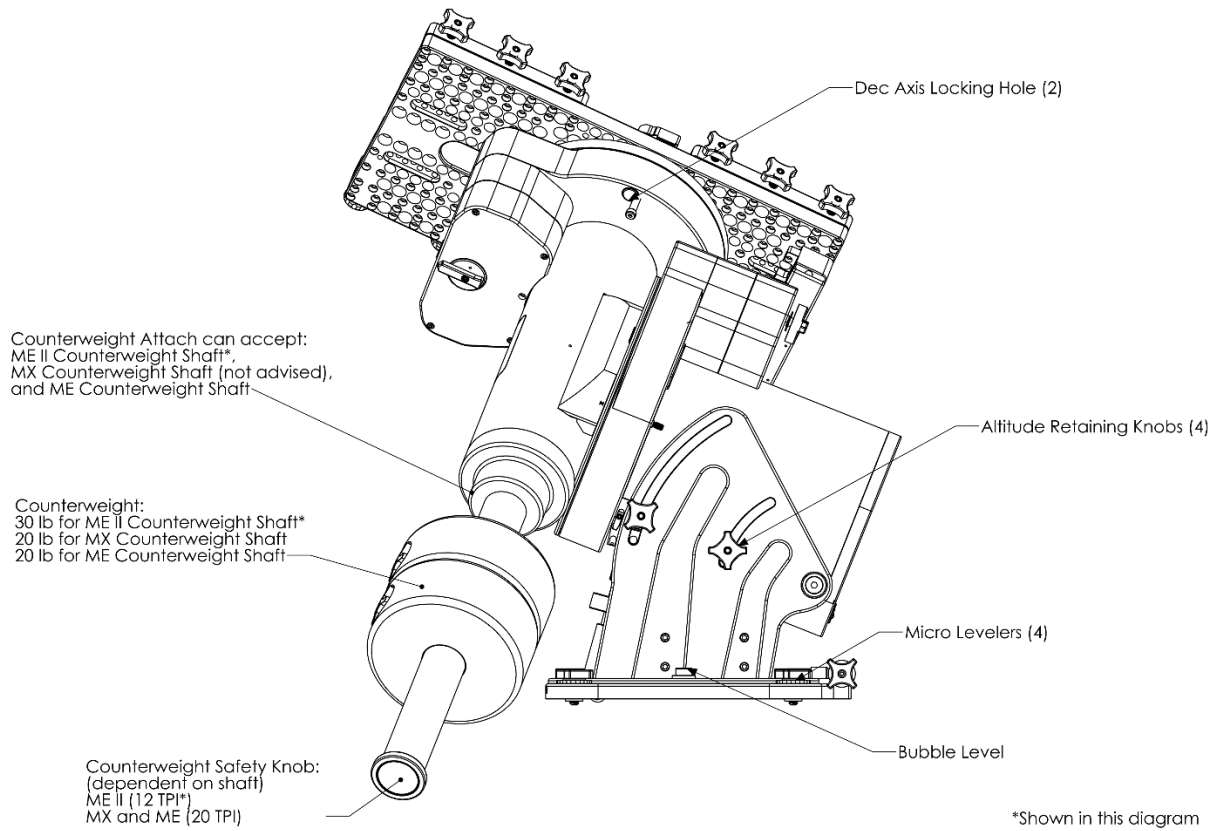

Figure 58: The side view of the Paramount ME II.

Paramount MX Side View

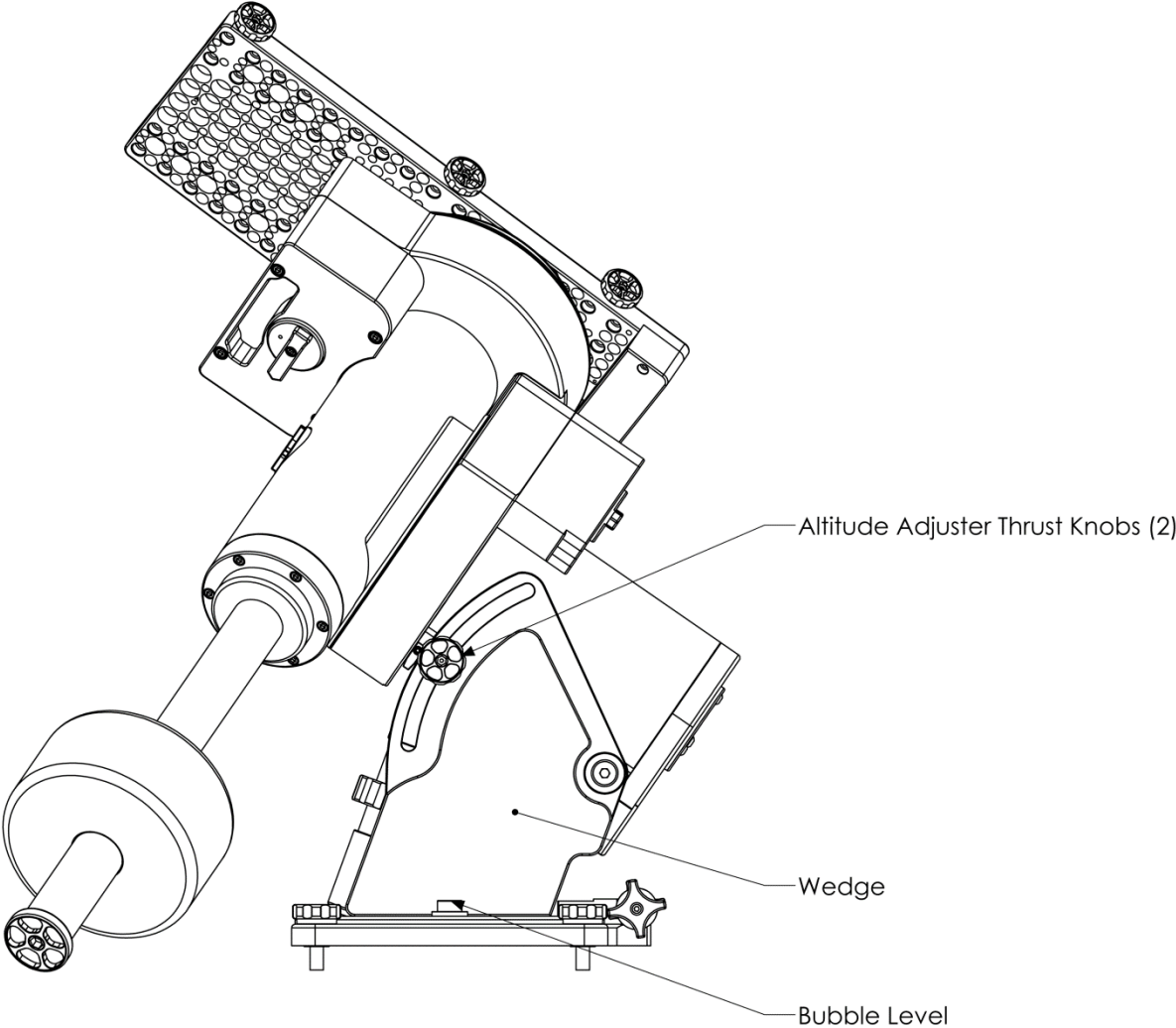

Figure 59: The side view of the Paramount MX.

Paramount MX+ Side View

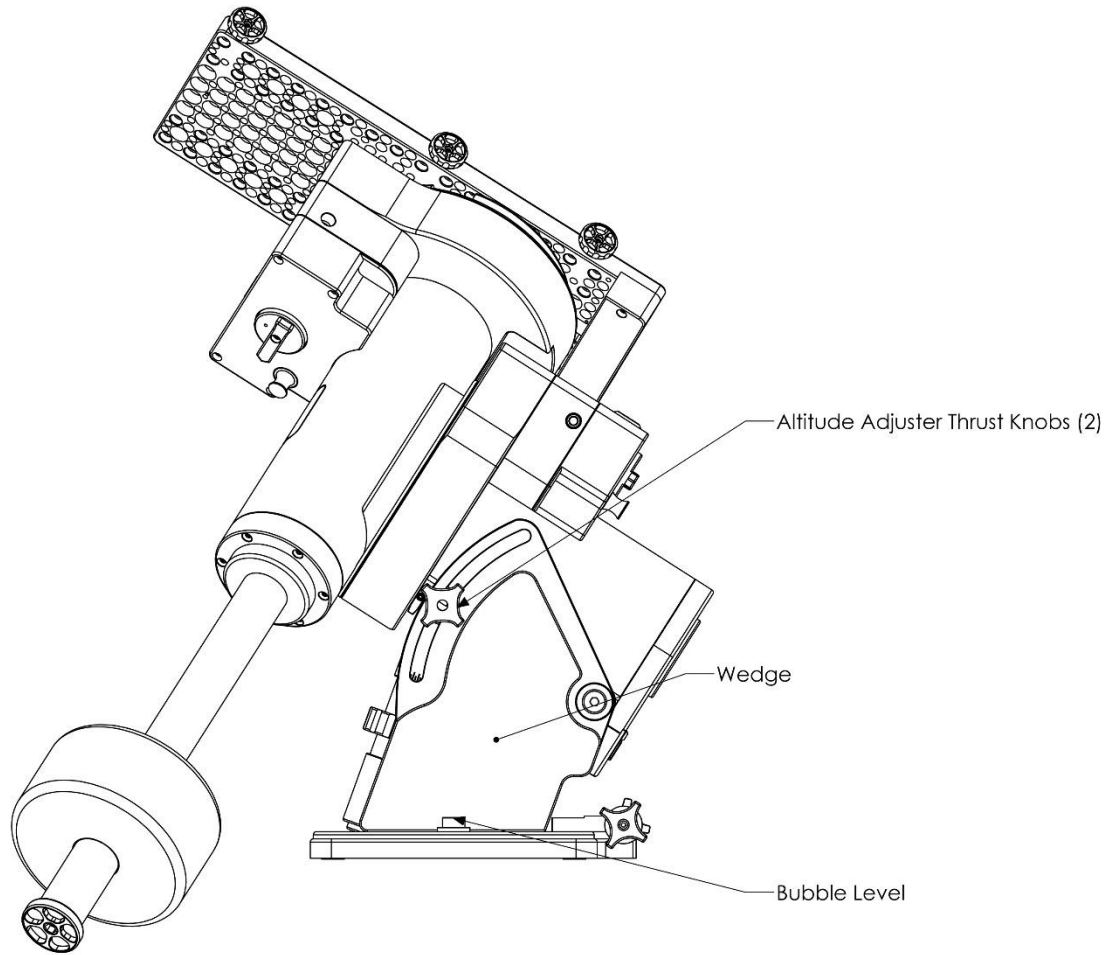
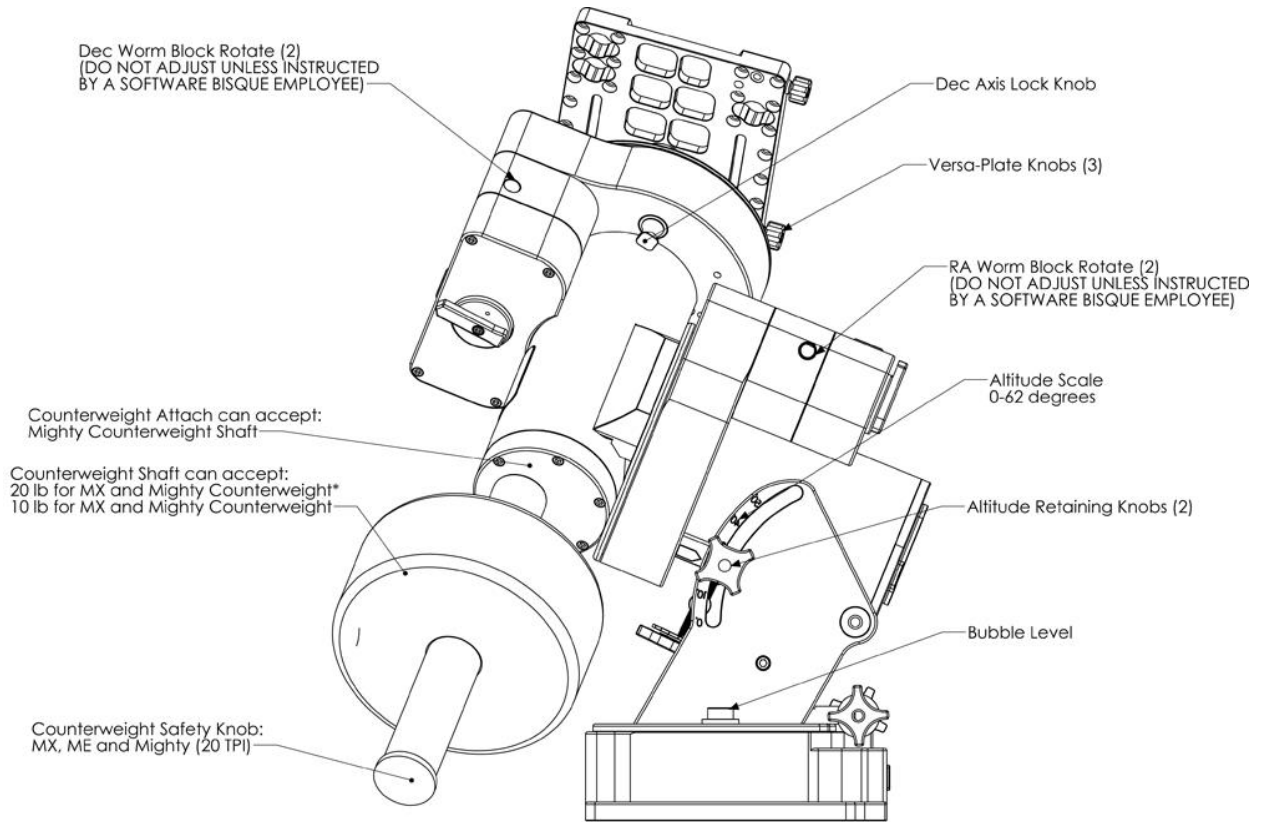

Figure 60: The side view of the Paramount MX+.



* Shown in diagram

Figure 61: Side view of the Paramount MvT.





Altitude Adjuster Thrust Knobs

The Altitude Adjuster Thrust Knobs are designed to lock the altitude component of mount’s polar axis in place, without changing the position of the azimuth axis. (Adjusting either axis during polar alignment for some commercial mounts can be a frustrating trial and error process when trying to clamp down on one axis actually moves the position of the other.)

Make sure to completely loosen each knob (four on the Paramount ME II and two on the Paramount MX and Paramount MX+) before attempting to rotate the Altitude Adjuster.

Wedge

The integrated Paramount wedge allows the altitude of the mount’s polar axis to be adjusted to match the celestial pole. The table below shows the minimum and maximum elevation for each model. Software Bisque manufactures and sells a Paramount Latitude Adjustment wedges if astronomy takes you outside these latitudes.

Model	Minimum and Maximum Altitude of Wedge
	14° – 68° URL for Latitude Adjustment Wedge (for latitudes outside this range): https://www.bisque.com/sc/shops/store/Latitude-Adjustment-Wedge.aspx
 	10° – 65° URL for Latitude Adjustment Wedge (for latitudes outside this range): http://www.bisque.com/sc/shops/store/MXLatitudeAdjustmentWedge.aspx
	0° – 64°

Bubble Level

The Paramount bubble level is suitable for the most demanding astronomy work, and can make polar alignment easier when no polar alignment scope is available.



Figure 62: Center the bubble in the black ring for best results.

One-tenth of one inch motion in the level bubble's level equates to 45 arcminutes of angular "tilt." Positioning the bubble in the center of the black ring means the mount is level to within 5 arcminutes.

Remember, the base of a GEM does not *have to be* perfectly level to achieve precision tracking. As an extreme example, provided the equatorial axis is pointed to the refracted celestial pole, the base of a GEM could be vertical and still follow the stars.

If the mount's base is not close to horizontal, adjusting one axis pollutes the position of the other axis and makes the process of polar alignment more difficult.

Declination Axis Locking Hole (Paramount ME II Only)

The Paramount ME II's declination axis can be locked into position by screwing two shoulder bolts (supplied with mount) into these holes.



When installed, the right ascension and declination axis locking bolts are designed to prevent the axis from rotating during shipment and while adding payload. As a best practice, always try to maintain a balanced payload, even when mounting equipment.

The shoulder bolts are not designed to carry the mount's entire payload. If you mount an excessively unbalanced payload on the declination axis, for example, you run the risk of bending one or both of the bolts, making removal difficult.

The specifications for right ascension axis locking shoulder bolt are:

- 18-8 stainless steel shoulder screw
- 5/16-in. shoulder diameter
- 2-1/4-in. long shoulder
- 1/4 in.–20 thread

The declination axis locking shoulder bolt has the same specifications, but is 1-3/4-in. long.

Micro Levelers (Paramount ME II Only)

The Paramount ME II uses integrated Micro-Levelers and Base Plate Attachment Knobs to level and secure the mount to the pier or base plate. Please carefully read the following section before continuing.

Adjusting the Micro-Levelers

The Paramount ME II's Micro-Levelers are used to fine-tune the mount's level. The maximum amount of adjustment for each leveler is approximately 3 mm or 1/8-inch. The Micro-Levelers are also used to ensure that the base plate of the Paramount ME II is not distorted by an uneven mounting surface.

Important note: the Micro-Levelers *must* protrude slightly below the surface of the Base Plate before tightening the Base Plate Attachment Knobs. See the "Critical Micro Leveler Note" below for more information.

The best approach for leveling the mount is to simultaneously rotate two Micro-Levelers so that the mount is tilted either north/south or east/west. The accuracy of the leveling required depends on the long-term use of the mount. If the mount is attached to a permanent pier, without the intent of portable use, leveling is less important. When used in a portable sense, a level mount helps speed the polar alignment process.

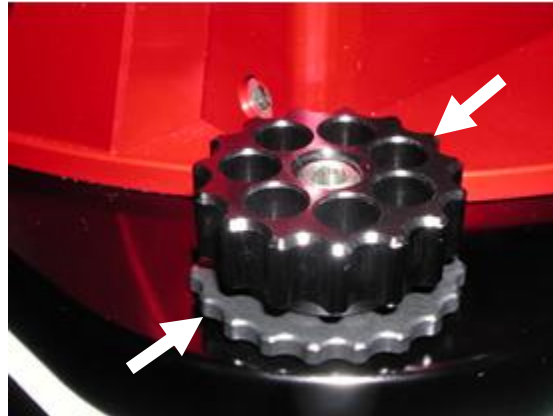

Figure 63: Micro-Leveler (lower left arrow) and Base Plate Attachment Knob (upper right arrow).



Critical Micro Leveler Note

The Micro-Levelers and Base Plate Attachment Knobs both serve different purposes. The Micro-Levelers stabilize and level the Base Plate on the mounting surface.

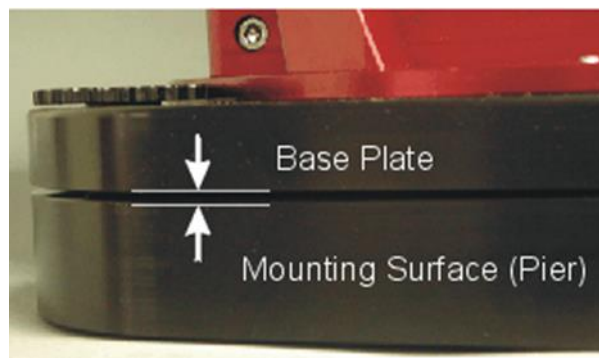

Figure 64: Adjusting Micro-Levelers.

The Base Plate Attachment Knobs secure the Base Plate to the pier. Both components have unique thread patterns, and the two *will bind together* when improperly adjusted.

The weight of the mount must be resting on all four Micro-Levelers, and *not* against the surface of the Base Plate. In other words, the Base Plate should sit at least one millimeter (or so) above the mounting surface (such as the top of the pier or, or the pier adaptor plate).

To make sure this occurs, *before* tightening the Base Plate Attachment knobs, rotate each Micro-Leveler clockwise until it makes contact with the mounting surface. Then tighten it about 1/16 of a turn (or so) more. Additional adjustment may be required to accommodate uneven mounting surfaces. You might want also want to gently lift the mount when tightening the Micro-Levelers.

If all four Micro-Levelers are not in contact with the mounting surface, when you attempt to loosen a Base Plate Attachment Knob, both will turn together and bind. They *cannot* be turned in unison because the threads on the Micro-Leveler are larger than the threads on the Base Plate Attachment Knob. If the two become bound, **do not try to force them apart!** Instead *tighten* (yes, tighten) both knobs a small amount until they are no longer bound. At this point, rotate the Micro-Leveler clockwise until it is in full contact with the mounting surface.

Hand Controller

The Paramount includes a hand controller that can be used to slew and home the mount without the need of *TheSkyX Professional* Edition, as well as turn on mount lighting and an integrated LED flashlight.

To use the joystick, plug the RJ12 phone-type connector on the end of the hand controller's 15-foot coiled cable into the Joystick port on the Electronics Box (page 79). The hand controller includes an integrated mini joystick and a large five position rate switch that allows single-handed slews and slew rate control. Double-tap the joystick to optionally issue the **Find Home** command (no external software required).



Figure 65: The Paramount hand controller.

The three position rocker switch located on the side of the hand paddle turns the mount's lighting features on or off.

- Rock and click the switch downward (toward the bottom of the hand paddle) to turn on and illuminate the bright red LED located on the top of the housing. The hand paddle now acts as a night-vision preserving flashlight. Return the switch to the center position to turn the LED off.
- Rock the switch upward (toward the top of the hand paddle) to turn on several bright LEDs that are located in the Electronics Box and Instrument Panel. The “landing lights” are handy to illuminate your working area when setting up, during polar alignment or shutting down for the night. When released, the switch automatically returns to the center position and does not stay in the forward position. (Note that a Paramount ME equipped with the MKS 4000 control system does not have landing lights.)
- Press and hold the switch upward to turn on the LED flashlight (while the switch is held in the forward position) and the landing lights simultaneously.

The large cable loop on the top of the hand controller can be used to hang it in a convenient location when not in use.

Slew Rate Switch

The slew rate switch can be adjusted to five positions. Positions 1-4 are labeled on the hand paddle cover and by default the higher the number, the faster the rate. Rotating this switch counterclockwise to the unmarked position disables slewing via the joystick. The default slew rates are shown below.

Switch Position	Default Slew Rate (x Sidereal)
Fully counterclockwise (unlabeled)	0x*
1	0.33x
2	3x
3	600x
4	1200x

* The slew rate for this position cannot be changed.

The rates for slew rate switch positions 1-4 can be configured when the hand controller is plugged into the MKS 5000 control system. See “Hand Controller Settings” on page 170 for information how to do so.



The hand controller is compatible with the Paramount ME (specifically, MKS 4000 control systems using firmware version 2.8.6 or later). However, the hand controller’s slew rates are not configurable when used in conjunction with the MKS 4000. In other words, the default slew rates are configurable only via the MKS 5000 control system.

Other Paramount Accessories

USB Cable





The USB cable has a 5 pin Mini-b USB style connector that plugs into USB port on the Electronics Box and a standard USB-A plug that plugs into the PC.

Hex Wrenches

The Paramounts comes with a set of standard Imperial-size hex wrenches that can be used to tighten the Versa-Plate knobs (page 64), add or remove the polar alignment scope (page 83), loosen the base (page 86) or altitude adjuster thrust knobs (109), and other common setup tasks.

Power Supply Unit (PSU)

The Paramount power supply unit is compatible with either +120 or +240V power sources and includes a NEMA 5-style three pronged connector. Country-specific power plugs can be purchased at many hardware or electronics shops. The table below shows the PSU specifications for each model.

Model	Power output (max)	Input	Output
	221W	100-240VAC 50/60 Hz 4.0A	48V 4.6A max.
  	80W	100-240VAC ~47-63 Hz 1.9A	48V 1.66A max.

The Paramount MX+ and Paramount MYT comes standard with the 80W power supply which allows slew rates up to six degrees per second. The optional 221W can be purchased separately to achieve slew rates of 10 degrees per second.

Altitude Adjuster Wrench (Paramount ME II Only)

The Paramount ME II includes a removable Altitude Adjuster Wrench that makes rotating the Altitude Adjuster Knob easy, even with heavy a payload attached to the mount.

The circular section of this wrench fits over the Altitude Adjuster Knob and will drop into place on the top of the knob when the wrench and knob tics are aligned. Once seated, you can rotate the knob using the increased leverage from the protruding arms to make polar axis elevation adjustments.

How to Polar Align

Once the Paramount has been securely mounted to the pier or tripod, the next step is to align the mount's polar axis with the celestial pole. Make sure to review "Polar Alignment" on page 21 for an explanation why polar alignment is so critical for an equatorial mount.

Software Bisque recommends starting with the rough polar alignment method, then using either the polar alignment 'scope or *TheSkyX Professional's* Accurate Polar Alignment feature to refine the alignment. Note that the accurate polar alignment procedure requires a TPoint model; please refer to the *TPoint Add*

On User Guide to learn more about telescope calibration and modeling. If a different polar alignment technique works for you, by all means, use it!

Rough Polar Alignment Method

When the base of the Paramount is approximately level, and the Paramount is at the home position, the fixed mechanical orientation of this position can be used in conjunction with *TheSkyX Professional Edition* to polar align the mount to within about 10 arcminutes of celestial pole (which is a good *starting point*).

When the Paramount is positioned at the home position, the mount's mechanical orientation is always identical (to about one arcsecond or so). In the northern hemisphere, this position points very near hour angle 2.0 and declination 0.0. For a mechanically perfect imaging system, the telescope would be pointing to a position on the celestial sphere that is exactly two hours west of the meridian on the celestial equator.

Provided the base of the mount is close to level, and the altitude of the polar axis closely matches the observing site's latitude, *TheSkyX Professional Edition* (configured with accurate location, date, time and time zone settings) can be used to slew the mount to the *computed* position of an object (usually a star or other bright object) on the celestial sphere.

Once the telescope has been slewed to the object, the mount's ***mechanical azimuth axis*** (not the telescope's position) can be adjusted until the object is centered in the eyepiece. This technique relies on the home position and the computed equatorial coordinates of an object to approximately align the mount's polar axis to the celestial pole.

The rough polar alignment method can be performed during the daylight hours by slewing to a planet, bright star or even the sun (provided the proper solar filters are used). Another advantage to this technique is that the celestial pole need not be visible.

Note that while the home position is mechanically fixed, the telescope itself will not necessarily precisely point to hour angle 2.0 and declination 0.0. This is in part due to slight variations in the position of the emitter-detector pair in the home sensors, as well as optical and mechanical non-perpendicularities. For this reason, the rough polar alignment method should be deemed an "initial" and not "precise" polar alignment technique.

After performing a rough polar alignment, TPoint, or a polar alignment scope, can be used to further refine polar alignment.

Step-By-Step Rough Polar Alignment

To begin a rough polar alignment, from *TheSkyX Professional Edition*, click the ***Rough Polar Alignment*** command on the ***Tools*** menu and follow the step-by-step instructions. Note that the *Rough Polar Alignment* window can be resized larger to make the graphics larger and easier to read.

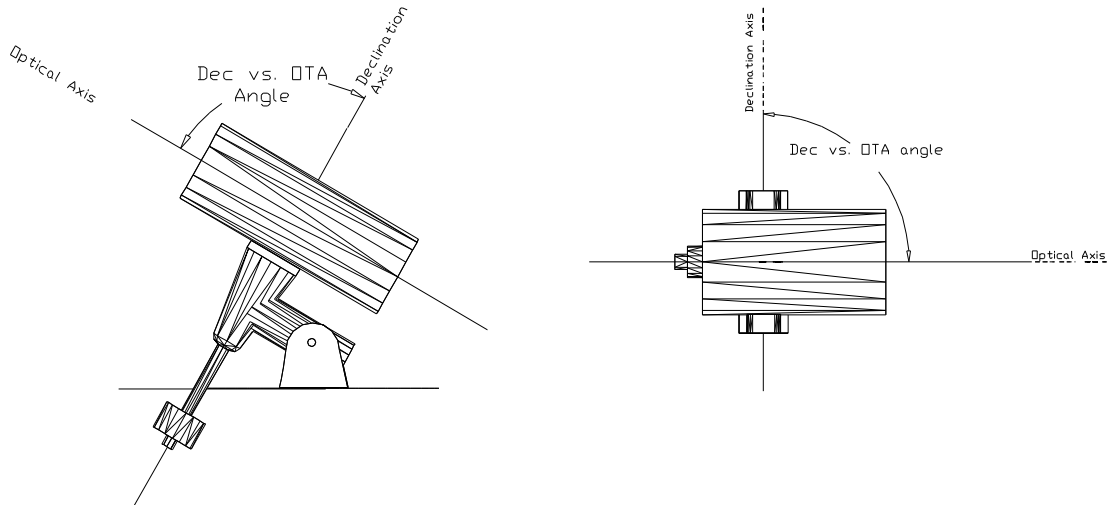

Figure 66: The OTA's optical and mechanical non-perpendicularity errors degrade the accuracy of the rough polar alignment method.

Note that optical and mechanical non-perpendicularities in the telescope and the declination axis play a key factor in the accuracy of the rough polar alignment method. If these misalignments are large (in the order of 30 arcminutes or greater), the initial polar alignment will not be as accurate.

Accurate Polar Alignment

For most amateurs, optimal tracking performance can be achieved when an equatorially mounted telescope is aligned to within about 100 arcseconds of the refracted pole. Coupled with a TPoint model, TheSkyX's *Accurate Polar Alignment* command makes getting there much less difficult.

The Accurate Polar Alignment Command

TPoint author Patrick Wallace developed an ingenious method to accurately, and relatively painlessly align an equatorial mount's polar axis with the celestial pole based on a TPoint model.

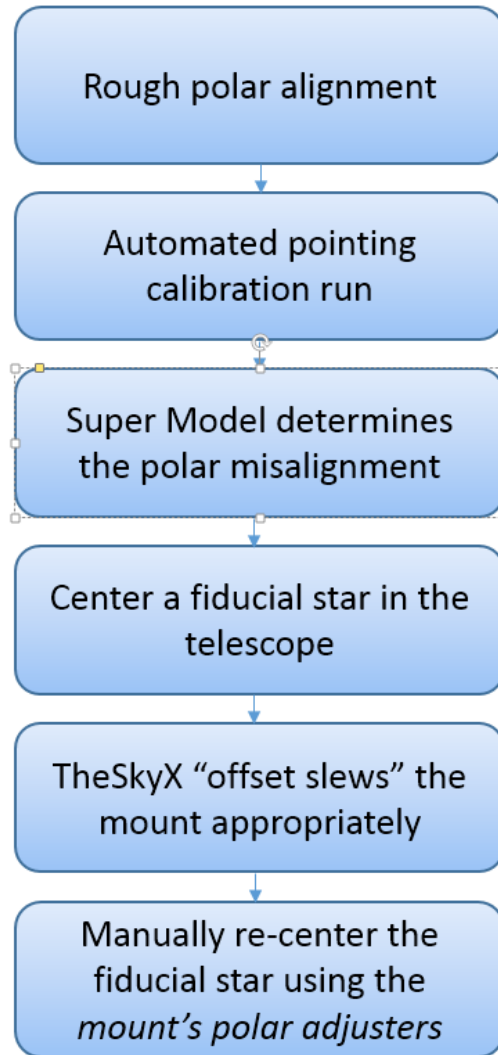

Figure 67: The Accurate Polar Alignment workflow.

Figure 67 shows the accurate polar alignment workflow. Once a telescope has been setup, roughly aligned with the pole, and calibrated, TPoint’s Super Model can be used to determine and report the mount’s polar misalignment in the TPoint Polar Alignment Report. Before *TheSkyX’s* Accurate Polar Alignment feature was available, the challenge was to use this information to make mechanical adjustments to the mount’s polar axis. Even with calibrated mechanical polar alignment mechanisms like those found on the Paramount, hitting the alignment “sweet spot” was often error prone. Slop in many mounts mechanical polar adjusters introduce yet another impediment to success.

Enter the “closed loop feedback” of the Accurate Polar Alignment procedure that ensures an accurate alignment.

After making sure the existing TPoint model is sufficient, the Accurate Polar Alignment wizard instructs you to identify a star located near the meridian, in the north or south, and then center this star in the

eyepiece. After confirmation this step is complete, the wizard then performs an “offset slew” based on the TPoint polar misalignment, so that the star can be centered again using the mount’s *mechanical polar alignment adjusters*.

If you are not familiar with TPoint, pointing calibration, Super Model, or the **Polar Alignment Report**, please refer to the *TPoint Add On User Guide*. This document can be viewed in PDF format by clicking the **TPoint Add On User Guide** command from *TheSkyX Professional Edition’s Help* menu. The latest revision can be downloaded from the Software Bisque web page by clicking **Downloads > Documentation > TheSkyX User Guides > TPoint Add On User Guide**. The URL to this document is: <http://www.bisque.com/sc/media/p/28065.aspx>.

Polar Alignment Quick Start Guide

1. Use the “Rough Polar Alignment Method” (page 114) to approximately align the mount with the celestial pole.
2. As described in the *TPoint Add On User Guide*, perform an automated pointing calibration run to get an accurate estimate of the polar misalignment.

The number of points used in the initial calibration can vary greatly depending on your needs. As few as 12 calibration points can be used to characterize the polar misalignment on portable setups, or if you’re just learning the ropes. For permanent installations, or portable setups where you want to completely characterize the mount’s behavior, you might opt to collect 150 or more calibration points before generating the Super Model. If the equipment on the system, or the polar alignment changes in the future, or you’re setting up the mount each night, a portable *recalibration* can be done to reestablish the pointing accuracy in the original model.

3. When the pointing calibration is complete, create the Super Model based on this data. The polar misalignment details are available on the **Polar Alignment** tab of the **TPoint Add On** window.
4. From *TheSkyX Professional Edition*, choose the **Accurate Polar Alignment** command from the **Tools** menu and follow the step by step instructions.

Once this Accurate Polar Alignment wizard is completed, the mount is now accurately aligned with the pole. The TPoint model is also updated to automatically to reflect the polar alignment.

Each time your portable systems is setup going forward, perform a recalibration using the **Portable** option so that the new polar alignment offsets can be determined.

Using the Polar Alignment Scope

After mounting the polar alignment scope to the front of Paramount (page 83), follow the manufacturer’s instructions to calibrate the scope, and then place Polaris in the polar scope’s reticule.

The Paramount and TheSkyX Professional Edition

The Paramount Robotic Telescope Mount utilizes the *Bisque Telescope Control System* (Bisque TCS) with the MKS Series dual axis motion controller electronics. This control system provides ultra-precise pointing and tracking, configurable software slew limits, current limited motor shut down, auto homing, high frequency position monitoring, easy firmware updates and more.

The version of the Bisque TCS that came with your Paramount depends on the model and date of purchase:

- The MKS 5000 is included with the Paramount ME II, Paramount MX, Paramount MX+, Paramount MyT and Bisque Telescope Control System (TCS) units shipped after December 2012.
- The MKS 4000 is included with all Paramount ME mounts from 2003 through May 2012 (when production of this model ended). An optional MKS 5000 upgrade for Paramount ME mounts is available on the Software Bisque Store.
- The MKS 3200 was included with Paramount ME mounts from 2002-2003.
- The MKS 3000 was included with Paramount GT-1100S mounts from 1999-2002.

See the Paramount ME User Guide for details on the MKS 4000 and earlier control systems.

Paramount Minimum System Requirements

The Paramount requires the following minimum hardware and software to operate:

- A Mac or Windows computer with *TheSkyX Professional Edition* installed. See *TheSkyX Professional and Serious Astronomer Edition User Guide* for minimum hardware requirements.
- or-
- An iPhone or iPad running TheSky for iOS. The optional WiSky Wi-Fi module (see below) is required.
- One free USB port on the computer. The MKS 5000 communication port uses a USB hardware interface.
- One USB cable (included). Optional USB cable extenders can be used to allow the length of the USB cable to be increased to 30 meters or so. If the distance between the computer and mount is greater than 30 meters, consider using a high-quality USB Ethernet Extender.



The Paramount's USB port and the USB hub on the Instrument Panel have been tested extensively with many common commercial cameras and other USB-based astronomical devices on Mac and Windows operating systems. Provided a 15-foot USB cable between the computer and the mount is used, both the USB port and the USB hub are extremely reliable and provide consistent hardware to software communications.

Extending the length of the USB cable between the mount and computer using inexpensive USB cable extenders, or plugging in a second, inexpensive USB hub to the USB hub on the Instrument Panel will, most likely, introduce inconsistent and unreliable communication between either the mount or the camera or other USB device. See “USB Hubs and USB Extenders ” on page 178 for more information on this topic.

- An optional WiSky Wi-Fi communications board allows any Windows or Mac computer with a Wi-Fi adaptor running TheSkyX Professional Edition, or any iPhone or iPad running TheSky for iOS.
- One Paramount power supply (included).

-or-

- An optional 48V battery. Software Bisque sells an *EGO™ Battery to Paramount Power Adaptor* that allows the same EGO batteries that power your outdoor equipment to power the Paramount (EGO batteries sold separately).

First Time Paramount Setup

Please make sure to carefully read both the *Paramount Unpacking* insert and the Paramount Quick Start Guide in the Paramount boxes before using the mount.

After the Paramount has been unboxed and safely attached to your tripod or pier, the next step is to connect the power and communication cables to the Electronics Box so that mount can be turned on.

1. Plug the round end of the Paramount power cable into the port labeled *48V Power In* on the Electronics Box and the other into an electric outlet.
2. Plug the mini USB end of the USB cable into the Electronics Box port labeled **USB** and USB A connector into a free USB port on the computer.
3. Flip the On/Off switch up to the on position.

When the Paramount is turned on, three LEDs on the Electronics Box are illuminated and a short “whistle” is emitted to indicate the control system has been successfully initialized. (The LEDs labeled **RA** and **Dec** are orange; LED labeled **TCS** varies from blue to purple). Two successive beeps are emitted shortly afterward indicating the servomotors have been initialized.

An example audio clip for a successful startup is available here:

<http://www.bisque.com/sc/media/p/50821.aspx>



Exactly *when* the two motor initialization beeps occur may be *different for each mount* and will *vary depending on the mount's current mechanical orientation*. The beeps may even occur simultaneously so that only a single beep is audible.

If the LEDs on the Electronics Box are illuminated, and the mount homes, the control system is functioning normally.

Paramount USB Driver Installation

Before attempting to control the Paramount from *TheSkyX Professional Edition*, make sure to install the necessary drivers for your operating system.

Mac OS X

Software drivers need *not* be installed to operate the Paramount on the Mac. Plug the USB cable into the mount and into one of the computer's USB ports then follow the instructions below to configure *TheSkyX Professional Edition* for Mac.

Windows

The Software Bisque MKS 5000 USB driver must be installed before the Paramount can be operated by *TheSkyX Professional Edition* for Windows (both 32- and 64-bit Editions). See "Appendix A: Installing the MKS 5000 USB Windows Driver" on page 181 for step by step installation instructions.

Controlling the Paramount with TheSkyX Professional Edition

After installing the MKS 5000 driver (Windows only), and plugging the USB 2.0 cable into the mount and computer, you must configure *TheSkyX Professional Edition* to control the *Paramount*.

1. Make sure the mount is turned on so that the computer recognizes the Paramount USB port.



The Paramount must be turned on before the operating system will recognize the built-in USB port on the Electronics Box.

2. From *TheSkyX Professional Edition*, choose the **Telescope Setup** command from the **Telescope** menu.
3. On the **Imaging System Setup** window, highlight **Mount** in the **Imaging System** list.
4. Select the **Choose** command from the **Mount Setup** pop-up menu.
5. Expand **Software Bisque**, select **Paramount ME II**, **Paramount MX** or **Paramount MX+** and click **OK**.
6. Choose the **Settings** command from the **Mount Setup** pop-up menu.



On the Mac, the Paramount control system name is "usbmodem" with a "numerical identifier" (see Figure 68). The numerical identifier in the name varies depending on which version of Mac OS X is installed.

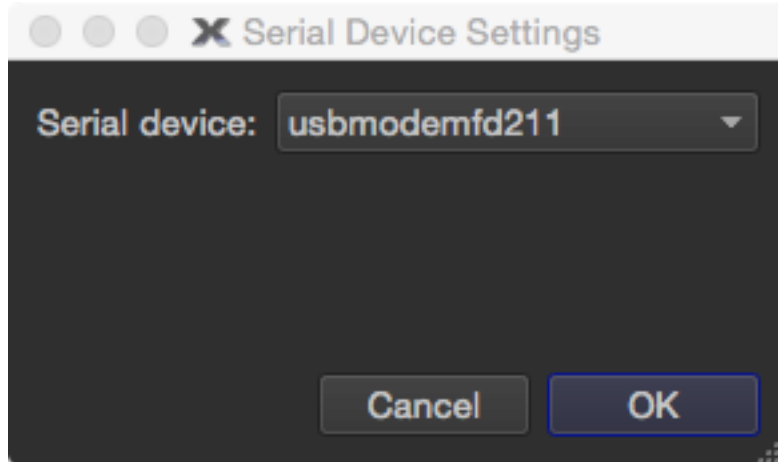

Figure 68: The Mac Serial Device Settings window.



On Windows, select the COM port number that Windows has assigned to the Paramount MX/MX+'s USB port (see page 182 for details about installing the MKS 5000 driver) and click **OK**. The **Description** of the **Port** in the **Serial Port** list appears as **Software Bisque MKS 5000**.

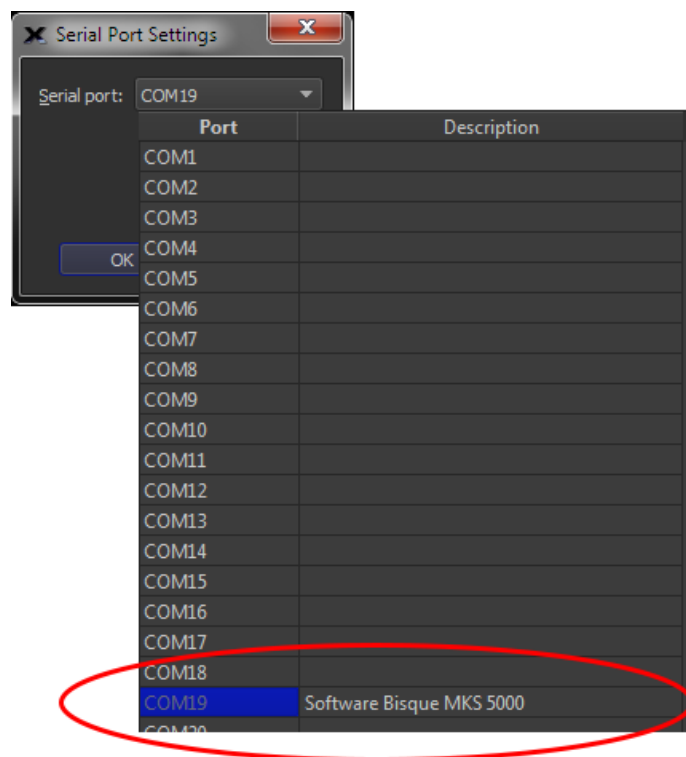

Figure 69: The Windows Serial Port Settings window.

7. Click the **Connect** command from the **Telescope** menu and then click the **Close** button on the **Imaging System Setup** window.

8. The **Telescope** window's **Status** text shows the current state of the mount.

Getting Started with TheSkyX Professional Edition

If you are not familiar with *TheSkyX Professional Edition's* basic telescope controls, please refer to *TheSkyX Professional Edition User Guide* for details about basic mount control features, including:

Feature	Quick Start Reference
Adding <i>TPoint Add On</i> Pointing Samples	Add Pointing Sample button on the Telescope window
Centering the Telescope Cross Hairs	Center Cross Hairs button on the Telescope window
Clearing the Park Position	Clear Park Position command from the Shut Down pop-up menu on the Telescope window.
Connecting, Disconnecting the Mount	Connect, Disconnect commands from the Telescope menu
Finding Home	Find Home command from the Start Up pop-up menu on the Telescope window or double-tap the joystick
Mount Status	Shown on Telescope window
Moving or Jogging the Mount	Move/Jog controls on the Telescope window
Parking	Park command from the Shut Down pop-up menu on the Telescope window
Setting the Park Position	Set Park Position command from the Shut Down pop-up menu on the Telescope window
Slewing	Slew button on the Telescope window
Star Searching	Star Search command from the Tools pop-up menu on the Telescope window
Star Synchronization	Synchronize command from the Start Up pop-up menu on the Telescope window
Telescope Configuration	Telescope Setup command from the Telescope menu
Tracking Spacecraft	Track Satellite button on the Telescope window
Tracking Stars, Comets, or Asteroids	Set Track Rates button on the Telescope window
Turning Sidereal Tracking On	Turn Sidereal Tracking On command from the Tools pop-up menu on the Telescope window

Feature	Quick Start Reference
Turning Tracking Off	Turn Tracking Off command from the Tools pop-up menu on the Telescope window
Unparking	Unpark command from the Shut Down pop-up menu on the Telescope window
Virtual Mount	Virtual Mount command from the Tools pop-up menu on the Telescope window

The Bisque TCS Window

The **Bisque TCS** window can be used to set every Bisque TCS parameter directly from *TheSkyX Professional Edition*. Earlier versions of *TheSky* required a separate application to view and configure advanced settings.

The **Bisque TCS** window also allows saving and restoring the mount's current firmware settings, provides advanced periodic error correction curve fitting, shows mount status, synchronization history and offers many other useful tools for monitoring the mount's status and providing troubleshooting information.

To view the **Bisque TCS** window, connect to the mount by choosing the **Connect** command from the **Telescope** menu. Next, choose the **Bisque TCS** command from the **Tools** pop-up button on the **Telescope** window. If the **Telescope** window is hidden, click the **Telescope** command from the **Display** menu to show it.

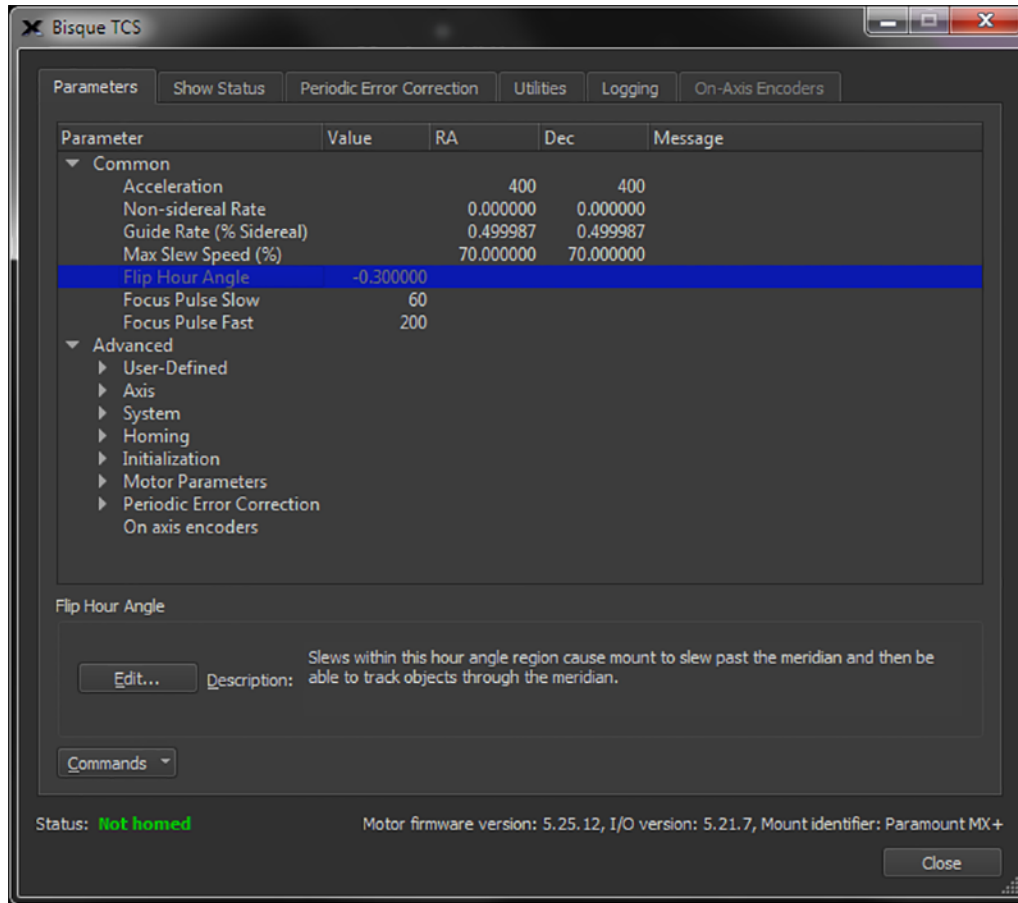

Figure 70: The Parameters tab of the Bisque TCS window.

The **Bisque TCS** window includes the **Parameters**, **Show Status**, **Periodic Error Correction**, **Utilities** and **Logging** tabs.

Status Messages (Status Text)

The always visible **Status** message on the bottom of the window shows color-coded text about the mount’s current state. (Mount status messages are repeated on the **Telescope** window.) See “Mount and Status” in *TheSkyX Professional Edition User Guide’s* Telescope documentation for a detailed explanation of each status message.

Firmware Version and Mount Identifier

The bottom right side of the Bisque TCS window shows the current firmware version of the Bisque TCS, as well as the mount identifier: *Paramount MEII*, *Paramount ME*, *Paramount MX*, *Paramount MX+* or *Bisque TCS*.

Parameters Tab

The **Parameters** tab shows the various Bisque TCS settings that can be modified. Parameters are divided into **Common** and **Advanced** categories. The common parameters, such as the mount’s acceleration, are

commonly changed to accommodate heavier payloads or other personal preferences (for example, you might want to lower the maximum slew rate because, “*I don’t want my expensive equipment slewing around so fast!*”).

Advanced settings are mount-specific control system configuration options that are used for custom (non-Paramount) mounts. Most advanced parameters **should not be modified for Paramount ME or Paramount MX mounts**. Each parameter is displayed in the **Description** text box at the boom of the window. Click the parameter’s name in the tree list to view its current value. Click the **Edit** button to change the value for this parameter; altered parameters appear in red text.

Common Parameters

The most commonly changed Bisque TCS parameters are described below.

Common Parameter Name	Description
Acceleration	The motor's relative acceleration/deceleration setting. Lower numbers (for example, 250) yield slower acceleration and deceleration while higher numbers (for example, 750) yield faster acceleration and deceleration.
Non-sidereal Rate	The non-sidereal rate, in arcseconds per second, is the rate added to or subtracted from the sidereal tracking rate. Although this rate can be set manually, <i>TheSkyX Professional Edition</i> can set the rate automatically. See the Set Track Rates button documentation for details how to do this.
Guide Rate (Fraction of Sidereal)	This value reflects the rate at which the telescope is moved when autoguider corrections are made. The general rule of thumb is that the fewer number of corrections to the mount’s position that are made during autoguided exposures, the better the resulting star profile. So, a the guide rate of 0.5 sidereal rate (the default setting) is the optimal value to achieve this goal.
Max Slew Speed (%)	The percentage of the mount's maximum slew rate that is used when slewing the mount. The default 90 percent. <ul style="list-style-type: none"> • The Paramount ME’s maximum slew rate in right ascension is 3.5 degrees per second and 5 degrees per second in declination, so the maximum default slew rate is approximately 3.2 and 4.5 degrees per second. • The Paramount ME II’s maximum slew rate is over 4 degrees per second in both axes.

Common Parameter Name	Description
	<ul style="list-style-type: none"> • The Paramount MX’s maximum slew rate in both right ascension and declination is 4 degrees per second. The default maximum slew rate in both axes is 3.6 degrees per second. • The Paramount MX+’s maximum slew rate and default maximum slew rate in both right ascension and declination is the same as the Paramount MX, with the included power supply unit. <ul style="list-style-type: none"> ○ A higher wattage power supply unit can be purchased separately which gives the Paramount MX+ the abilities to slew up to 10 degrees per second. The default maximum slew rate in both axes is 3.6 degrees per second.
<p><i>Flip Hour Angle (HA)</i></p>	<p>When slewing to a target object, the <i>Flip Hour Angle</i> parameter defines how the control system determines when the optical tube assembly will change sides of the pier.</p> <p>When a slew command is issued from <i>TheSkyX Professional Edition</i>:</p> <ul style="list-style-type: none"> • If the target’s hour angle is <i>less than</i> the Flip Hour Angle and less than , the OTA remains on the same side of the pier when slewing to the target. • If target’s hour angle is <i>greater than or equal to</i> the Flip Hour Angle, the OTA changes sides of the pier before slewing the target. <p>Configuring Flip Hour Angle Graphically</p> <p>When <i>TheSkyX Professional Edition</i> connects to the Paramount, the current flip hour angle is represented on the Sky Chart as an orange line drawn from the horizon to 90 degrees declination.</p>

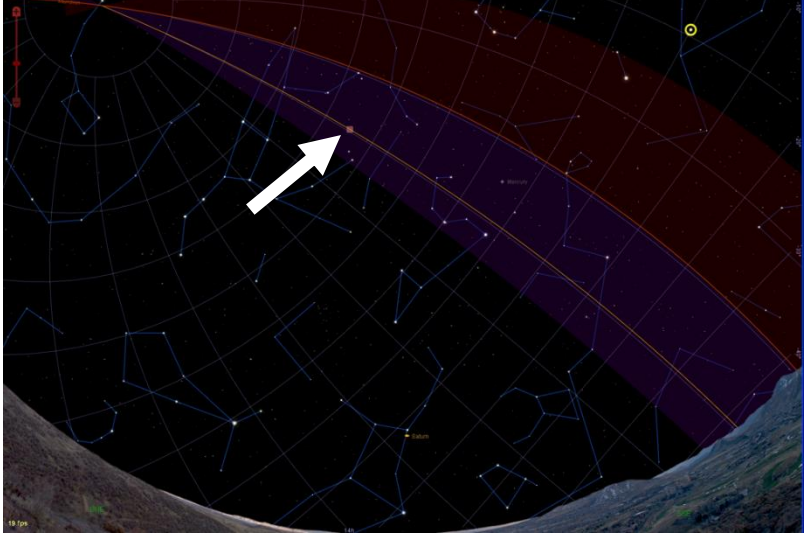
Common Parameter Name	Description
	 <p data-bbox="581 827 1398 854">Figure 71: The orange line on the Sky Chart represents the current flip hour angle.</p> <p data-bbox="558 884 1422 997">To dynamically change the flip hour angle, click and drag the orange “dragger” square on the flip hour angle line (see the white arrow on Figure 71).</p> <p data-bbox="558 1033 1422 1104">The mount will perform a meridian flip when it is slewed to an object on the “opposite” side of this line.</p> <p data-bbox="558 1140 1422 1253">The default value of this parameter is -1.0 for the Paramount MX and Paramount MX+, -0.3 for the Paramount ME and minus 3.0 (-3.0) for the Paramount ME II.</p>
Focus Pulse Slow	The number of milliseconds the built in focuser will be pulsed when the SLOW focus button is pressed.
Focus Pulse Fast	The number of milliseconds the built in focuser will be pulsed when the FAST focus button is pressed.

Advanced Parameters

Advanced parameters are divided into the following categories:

- Axis
- Homing
- Initialization
- Motor Parameters
- Periodic Error Correction
- System

- User-Defined















Most advanced parameters should not need to be changed unless you are using the Bisque TCS on a custom mounting. You may wish to change certain parameters, such as the maximum slew rate, based on the mount’s payload or to suit your personal preferences.

Axis Parameters	Description
Unit Identifier	This number relates to the TCS version and cannot be changed.
Non-sidereal Rate	<p>The non-sidereal rate, in arcseconds per second, is the rate added to or subtracted from the sidereal tracking rate.</p> <p>Although this rate can be configured manually, <i>TheSkyX Professional Edition</i> can perform this automatically. See the Set Track Rates button documentation for details how to do this.</p>
Guide Rate	<p>When the Bisque TCS guiding lines are activated, the increase or decrease in control system’s position occurs at this rate.</p> <p>The general rule of thumb is that the fewer number of corrections to the mount’s position that are made during autoguided exposures the better the resulting star profile. So, a guide rate of fifty-percent of sidereal rate (the default setting) is the optimal value to achieve this goal.</p>
Maximum Speed (%)	The percentage of the mount's maximum slew rate that is used to slew the mount.
Track Rate	The sidereal tracking rate in control system tracking units.
Min Position Limit	The Bisque TCS will not drive the motors beyond this minimum limit (decelerating stop).
Max Position Limit	The Bisque TCS will not drive the motors beyond this maximum limit (decelerating stop).
Joystick Center	The calibrated center position of the joystick.
Homing Parameters	
Relative Home Sensor Position	The <i>relative</i> home sensor position is computed using both the mount’s fixed homing sensor location and the equatorial coordinates supplied to <i>TheSkyX Professional Edition</i> when the mount was synchronized on a star.

Axis Parameters	Description
	<p>For a perfect mount that has no optical or mechanical misalignments, mechanical flexures or polar alignment errors, the relative home position would identically match the absolute mechanical home position. This is never the case. Misalignments in the mount’s mechanical axis and the telescope’s optical axis, for example, always introduce telescope pointing errors so there will always be a difference between the relative and absolute home position after synchronization.</p> <p>When the mount is synchronized to a known star, the “relative location of the home position” changes based on the pointing error introduced by the mechanical and optical misalignments.</p> <p>When the relative and absolute home sensor positions are equal, it means the mount has not yet been synchronized on a star.</p> <p>After synchronizing the mount, choose the Get All Bisque TCS Parameters command from the Commands pop-up menu on the Parameters tab (see page 137) to retrieve the control system’s current settings. Retrieving all the settings takes several seconds, so their values are not updated in “real time”.</p>
Home Required?	If set to 1, homing is required before slewing will occur (as with the joystick, etc.).
Home Direction	Initial direction to slew when searching for the home position “interruptor” (that is, the physical component on the gear that blocks the optical path of the homing sensor to signal the homing position).
Home Sense	Specifies whether the control system is looking for line high versus line low from the homing sensor.
Home Mode	1 = None, 2 = One sensor.
Home In-Out-In	Always set to 1.
Home Velocity High	This is the rate at which the homing process begins looking for the home sensor.
Home Velocity Medium	After the first pass of the interruptor, the motor reverses direction and searches at this rate.
Home Velocity Low	After the second pass of the interruptor, the motor searches at this rate.

Axis Parameters	Description
Home from Joystick?	When set to 0, double-tapping the joystick button will not find the home position. Set this value to 1 to allow homing with the joystick.
Absolute Home Sensor Position	<p>These values represent the coordinates of the home position based on the mount's mechanical homing sensor location.</p> <p>The Paramount ME, Paramount ME II, Paramount MX and Paramount MX+'s home position is hour angle (HA) 2.0 and declination 0.0 in the northern hemisphere and HA -2.0 and declination 0 when the mount is configured for the southern hemisphere (see "Hemisphere Setup" on page 156). These values cannot be changed.</p>
Initialization Parameters	
Focus Multiplier	A number between 1 and 100 that can be used to increase the mount's pulse focuser adjustment. The default value is 1.
Flip Hour Angle	See Flip Hour Angle on page 128 for a description of this parameter.
Temperature Slew Rate Reduction Percentage	Reduce the slew rate by this percentage when the ambient temperature drops below the <i>Temperature Slew Rate Threshold</i> value.
Temperature Slew Rate Threshold	When the ambient temperature, in Celcius, drops below this value, reduce the slew rate by the <i>Temperature Slew Rate Reduction Percentage</i> .
Kernel State	<p>The state of the ProTrack kernel.</p> <p>0 – Tracking adjustments off.</p> <p>1 – Tracking adjustments on.</p> <p>See "Activating ProTrack" on page 175 for more information.</p>
Call Level Logging	When turned on, all call level functions will be logged and displayed on the Logging window.
Packet Level Logging	When turned on, all packet level communications will be logged and displayed on the Logging window.
Focus Pulse Slow	The number of milliseconds the built in focuser is pulsed when the Slow focus button is clicked.

Axis Parameters	Description
Focus Pulse Fast	The number of milliseconds the built in focuser is pulsed when the Fast focus button is clicked.
Home After Connect	If set to 1, the mount will be homed after connecting if it is not already homed.
Show Limits	If set to 1, the telescope limits will be drawn either side of the meridian.
Log Slews	If set to 1, slewing information will be logged and displayed on the Logging window.
Prohibit Tracking Below Horizon	If set to 1, the mount's tracking will be turned off at the horizon. Otherwise, the tracking will not stop at the horizon.
Motor Parameters	
Index Angle	<p>The Paramount's DC servomotors require a unique motor index angle that is used during motor initialization. The motor index angles are preset at the factory, and should not be altered unless instructed to do so by Software Bique.</p> <ul style="list-style-type: none"> For the Paramount ME, the motor's index angle is affixed to a sticker on the motor, and can also be viewed on the Control System Parameters report (page 138). For the Paramount ME II, MX and MYT, the motor index angles are 200 for the right ascension axis, and 3850 for the declination axis. <p>Replacement MKS 5000 boards are normally pre-programmed with the correct motor index angles before shipment.</p>
EMF Constant	This value is based on DC servo motor type and motor size.
Max Voltage	Always set to 15.
Max Gain	Always set to 150.
Max Position Error	The maximum number of encoder tics from target before the Bisque TCS aborts slewing or tracking and begins to emit position error beeps.
Periodic Error Correction Parameters	
PEC Motor to Worm Gear Ratio	Specifies the gear ratio between the motor and the worm gear.

Axis Parameters	Description								
PEC Cutoff Speed	Set to two times the sidereal rate, this insures periodic error correction is not applied to higher slew rates. Attempting to apply PEC at high slew speed results in very labored sounding slews.								
PEC Harmonics	The number of harmonics to use when TheSkyX computes optimal PEC curve.								
PEC Ratio 1	The first gear ratio between the motor and worm.								
PEC Ratio 2	The second gear ratio between the motor and worm.								
PEC Ratio 3	The third gear ratio between the motor and worm.								
PEC Scale	The scale in arcseconds per pixel of the imaging system used to generate the PEC tracking log file.								
PEC Teeth on Gear	<p>The number of teeth on the mount’s main gear. This value defines the length of time for one revolution of the worm when the mount is tracking at the sidereal rate.</p> <table border="1" data-bbox="570 989 1416 1717"> <tbody> <tr> <td data-bbox="570 989 662 1171">  </td> <td data-bbox="669 989 1416 1171"> <ul style="list-style-type: none"> Tracking at the sidereal rate, one revolution of the worm takes 149.6 seconds (2 minutes 29 seconds). The right ascension gear has 576 teeth. The declination gear has 375 teeth. </td> </tr> <tr> <td data-bbox="570 1178 662 1360">  </td> <td data-bbox="669 1178 1416 1360"> <ul style="list-style-type: none"> Tracking at the sidereal rate, one revolution of the worm takes 149.6 seconds (2 minutes 29 seconds). The right ascension gear has 576 teeth. The declination gear has 475 teeth. </td> </tr> <tr> <td data-bbox="570 1367 662 1549">   </td> <td data-bbox="669 1367 1416 1549"> <ul style="list-style-type: none"> Tracking at the sidereal rate, one revolution of the worm takes about 230 seconds (3 minutes 50 seconds). Both the right ascension and declination gears have 375 teeth. </td> </tr> <tr> <td data-bbox="570 1556 662 1717">  </td> <td data-bbox="669 1556 1416 1717"> <ul style="list-style-type: none"> Tracking at the sidereal rate, one revolution of the worm takes 269 seconds (4 minutes 29 seconds). Both the right ascension and declination gears have 320 teeth. </td> </tr> </tbody> </table>		<ul style="list-style-type: none"> Tracking at the sidereal rate, one revolution of the worm takes 149.6 seconds (2 minutes 29 seconds). The right ascension gear has 576 teeth. The declination gear has 375 teeth. 		<ul style="list-style-type: none"> Tracking at the sidereal rate, one revolution of the worm takes 149.6 seconds (2 minutes 29 seconds). The right ascension gear has 576 teeth. The declination gear has 475 teeth. 	 	<ul style="list-style-type: none"> Tracking at the sidereal rate, one revolution of the worm takes about 230 seconds (3 minutes 50 seconds). Both the right ascension and declination gears have 375 teeth. 		<ul style="list-style-type: none"> Tracking at the sidereal rate, one revolution of the worm takes 269 seconds (4 minutes 29 seconds). Both the right ascension and declination gears have 320 teeth.
	<ul style="list-style-type: none"> Tracking at the sidereal rate, one revolution of the worm takes 149.6 seconds (2 minutes 29 seconds). The right ascension gear has 576 teeth. The declination gear has 375 teeth. 								
	<ul style="list-style-type: none"> Tracking at the sidereal rate, one revolution of the worm takes 149.6 seconds (2 minutes 29 seconds). The right ascension gear has 576 teeth. The declination gear has 475 teeth. 								
 	<ul style="list-style-type: none"> Tracking at the sidereal rate, one revolution of the worm takes about 230 seconds (3 minutes 50 seconds). Both the right ascension and declination gears have 375 teeth. 								
	<ul style="list-style-type: none"> Tracking at the sidereal rate, one revolution of the worm takes 269 seconds (4 minutes 29 seconds). Both the right ascension and declination gears have 320 teeth. 								
PEC Worm Periods	Number of worm revolutions to use in PEC curve determination.								
System Parameters									

Axis Parameters	Description
Mount Type	Defines the physical telescope mounting type: 0 = German Equatorial Mount. 1 = Asymmetric equatorial fork mount.
Sync Version	0 = Paramount ME, Paramount ME II, Paramount MX, Paramount MX+, Paramount MYT and Bisque TCS mounts. 1 = Paramount GT-1100S mount.
User Space Version	Shows the current version for the format of the user-defined data that is saved to the control system's flash memory.
Focus Axis	MKS 3200. MKS 4000, MKS 5000 and later should be set to 1. Otherwise, set this value to 0.
Mount Identifier	One of the following: <ul style="list-style-type: none"> • Paramount ME • Paramount ME II • Paramount MX • Paramount MX+ • Paramount MYT • Bisque TCS
Debug Output?	Set this value to 1 to show control system diagnostics.
Startup Test Joystick RA	If set to 1, then Bisque TCS will abort startup and emit a single beep if the joystick is not centered when power is turned on.
Startup Test Joystick Dec	If set to 1, then Bisque TCS will abort startup and the control system's speaker will emit a single beep if the joystick is not centered when power is turned on.
Startup Test Joystick Button	If set to 1, then Bisque TCS will abort startup and the control system's speaker will emit a single beep if the joystick button is pressed when power is turned on.
Startup Test Guider	If set to 1, then Bisque TCS will abort startup and the control system's speaker will emit a single beep if any of the guider lines are high when power is turned on.
Play Guider Sound	If set to 1, the Bisque TCS speaker will emit a single "click" each time the guider state changes.

Axis Parameters	Description
<i>IR Enabled</i>	If set to 1, then the infrared communications port is enabled (MKS 4000 only).
<i>Hand controller rate 1</i>	Hand controller rate number 1.
<i>Hand controller rate 2</i>	Hand controller rate number 2.
<i>Hand controller rate 3</i>	Hand controller rate number 3.
<i>Hand controller rate 4</i>	Hand controller rate number 4.
<i>General Purpose I/O 1</i>	General purpose output direction 1.
<i>General purpose I/O 2</i>	General purpose input/output toggle.
<i>General Purpose I/O 3</i>	General purpose output direction 2.
<i>General purpose I/O 4</i>	General purpose input/output toggle.
User-Defined Parameters	
<i>Acceleration</i>	The motor's relative acceleration/deceleration setting. Lower numbers (for example, 250) will yield slow acceleration/deceleration while higher numbers (for example, 750) will yield very fast acceleration.
<i>Max Slew Speed (%)</i>	The percentage of the mount's maximum slew rate that is used to slew the mount.
<i>Track Rate (% Sidereal)</i>	The mount's tracking rate, based on the percentage of the sidereal rate.
<i>Non-sidereal Rate</i>	The non-sidereal tracking rate in arcseconds/second.
<i>Guide Rate (% Sidereal)</i>	See page 130 for a description of this parameter.
<i>Tics/Revolution</i>	The total number of encoder tics per one complete revolution of the RA axis, computed by multiplying the gear ratio by 2000. For mounts located in the southern hemisphere, the RA value must be negative. See Hemisphere Setup in the Utilities Tab on page 156 for details about configuring the mount for the southern hemisphere.
<i>Relative Home Sensor Position</i>	See page 130 for a description of this parameter.

Commands Pop-up Menu

Use the **Commands** pop-up menu on the **Parameters** tab to retrieve the current settings from the Bisque TCS and to set the Bisque TCS settings.

Restore Defaults

Choose this command to display the **Restore Bisque TCS Defaults** window that can reset all the mount's parameters to default values. Note that the mount's synchronization history and periodic error correction table are preserved.

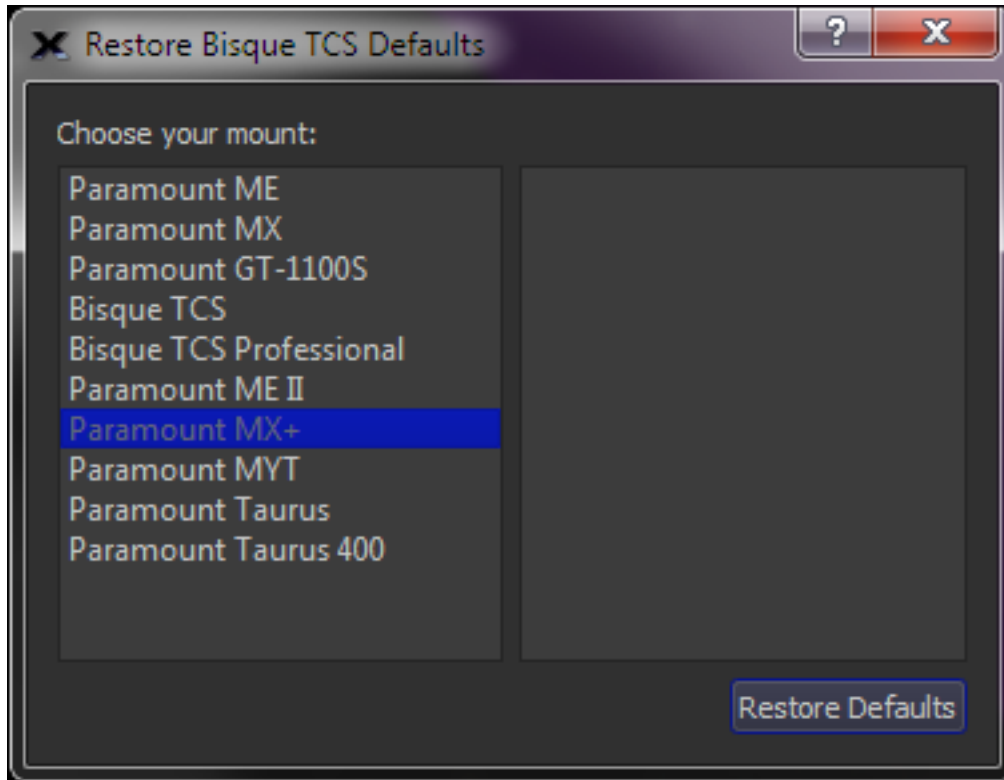

Figure 72: The Bisque TCS Configuration window.

The right side of the Bisque TCS Configuration window lists the mount models that use the MKS control system.

- Paramount ME
- Paramount MX
- Paramount GT-1100S
- Bisque TCS
- Bisque TCS Professional
- Paramount ME II
- Paramount MX+
- Paramount MYT

- Paramount Taurus Models 500 and 600)
- Paramount Taurus Models 400 and 400 OAE

The default parameters differ for each model mount, so make sure to choose the right one before clicking the **Restore Defaults** button.

Restore Defaults Button

Click this button to reset the mount's parameters to default settings. When prompted, click **Yes** to save the settings to the control system's flash memory.

Read All Parameters from Mount

Choose this command to read the mount's parameters from the control system and update them on the **Bisque TCS** window. Reading every parameter from the mount's internal memory is a relatively lengthy operation and this command may require fifteen seconds or so to complete.

Parameters to Mount

Choose this command to save the mount's parameters to the control system's flash memory. Saving every parameter to the mount's flash memory is a relatively lengthy operation and this command may require 15 seconds or so to complete.

Save the TCS Configuration File (Save As Command)

Save the current Bisque TCS parameters to a file. (Files are saved using the extension *.tcs*). This allows you to store different mount configurations and retrieve them as necessary using the **Open** command on the **Commands** pop-up menu.

Open Bisque TCS Configuration File (Open Command)

This command allows you to select and open a Bisque TCS configuration file.

Copy Parameters (From this Window to Clipboard)

Choose this command to copy a report of the current Bisque TCS parameters to the Clipboard in ASCII text format. Use the **Paste** command from any text editor to view and save this report.



Software Bisque strongly recommends printing a copy of your mount's Bisque TCS Parameters and storing it with your permanent records. In particular, the values for the MKS_INDEX_ANGLE (both RA and Dec) are required if the control system electronics need to be replaced for any reason.

Example Bisque TCS parameters text file for the Paramount MX:

Bisque TCS Parameter	RA Value	Dec Value
MKS_INDEX_ANGLE	, 3978 ,	375
MKS_UNIT_ID_	, 5 ,	5
MKS_ACCELERATION	, 800 ,	800

```

MKS_HOME_VEL_HI , 1600000000 , 1600000000
MKS_HOME_VEL_MED , 1500000000 , 1500000000
MKS_HOME_VEL_LOW , 59000000 , 59000000
MKS_HOME_REQD , 1 , 1
MKS_HOME_JOYSTICK , 1 , 1
MKS_HOME_INDEX_OFFSET , 0 , 0
MKS_CREEP_RATE , 0 , 0
MKS_GUIDE_RATE , -700964 , 700964
MKS_EMF_CONSTANT , 30 , 30
MKS_MAX_SPEED , 1080000000 , 1080000000
MKS_BASE_RATE , -44861734 , 0
MKS_MIN_POS_LIMIT , -6250000 , -8500000
MKS_MAX_POS_LIMIT , 2250000 , 2500000
MKS_PEC_RATIO , 8 , 8
MKS_HOME_DIR , 1 , 1
MKS_HOME_SENSE , 1 , 1
MKS_HOME_MODE , 2 , 2
MKS_HOME_IN_OUT_IN , 1 , 1
MKS_PEC_CUTOFF_SPEED , 89723468 , 0
MKS_MAX_VOLTAGE , 15 , 15
MKS_MAX_GAIN , 150 , 150
MKS_MAX_POS_ERROR , 2000 , 2000
MKS_JOY_CENTER , 2184 , 2184
MKS_USER1_TICS360 , 12000000 , -12000000
MKS_USER1_dEXPECTED_HOME , 2.0000000 , 0.0000000
MKS_USER1_dHOME_SENSOR , 2.0000000 , 0.0000000
MKS_USER1_dBASE_RATE_PERC , 100.0000000 , 0.0000000
MKS_USER1_dCREEP_RATE_ASPTS , 0.0000000 , 0.0000000
MKS_USER1_dGUIDE_RATE_FACT , 0.5000000 , 0.5000000
MKS_USER1_dMAX_SLEW_PERC , 90.0000000 , 90.0000000
MKS_USER1_NMOUNT_TYPE , 0
MKS_USER1_SYNC_VERSION , 10000
MKS_USER2_NVERSION , 0
MKS_USER2_FOCUS_AXIS , 1
MKS_OTHER_MOUNT_ID , Paramount MX
MKS_OTHER_DEBUG_OUTPUT , 0
MKS_OTHER_STARTUP_JS_RA , 0
MKS_OTHER_STARTUP_JS_DEC , 0
MKS_OTHER_STARTUP_JS_BUTTON , 0
MKS_OTHER_STARTUP_JS_GUIDER , 0
MKS_OTHER_SOUND_GUIDER , 0
MKS_OTHER_GP_IO_1 , 0
MKS_OTHER_GP_IO_2 , 0
MKS_OTHER_GP_IO_3 , 0
MKS_OTHER_GP_IO_4 , 0
MKS_OTHER_JOY_RATE_1 , 277581
MKS_OTHER_JOY_RATE_2 , 2523471
MKS_OTHER_JOY_RATE_3 , 66123104
MKS_OTHER_JOY_RATE_4 , 1322462080
MKS_INI_FOCMULT , 1
MKS_INI_FLIPHA , -18.0000000
MKS_INI_SPEEDPERC , 60
MKS_INI_SPEEDTHRESH , 5
MKS_INI_KERNEL_STATE , 1
MKS_INI_CALLLEVELLOGGING , 0
MKS_INI_PACKETLEVELLOGGING , 0
MKS_INI_FOCUSPULSESLOW , 60
MKS_INI_FOCUSPULSEFAST , 200
MKS_INI_HOMEAFTERCONNECT , 0
MKS_INI_SHOW_LIMITS , 0
MKS_INI_LOG_SLEWS , 0
MKS_INI_PPEC_HARMONICS , 2

```

```

MKS_INI_PPEC_RATIO1      ,      1.0000000
MKS_INI_PPEC_RATIO2      ,      8.0000000
MKS_INI_PPEC_RATIO3      ,      1.0000000
MKS_INI_PPEC_SCALE        ,      1.0000000
MKS_INI_PPEC_TEETH        ,          375
MKS_INI_PPEC_PERIODS     ,          1
    
```

Paste Parameters (From Clipboard to this Window)

Choose this command to import the Bisque TCS parameters from the Clipboard. If the Clipboard holds the appropriately formatted text, the parameter values displayed in the **Bisque TCS** window are updated. Choose the **Save All Parameters To Mount** command to save the parameters to the mount’s flash memory.

Show Status Tab

The spreadsheet on the top of **Status** tab shows the current control system and motor status values for both the right ascension and declination axes. These values are useful for verifying the current tracking rate, slew limit conditions and other control system settings.

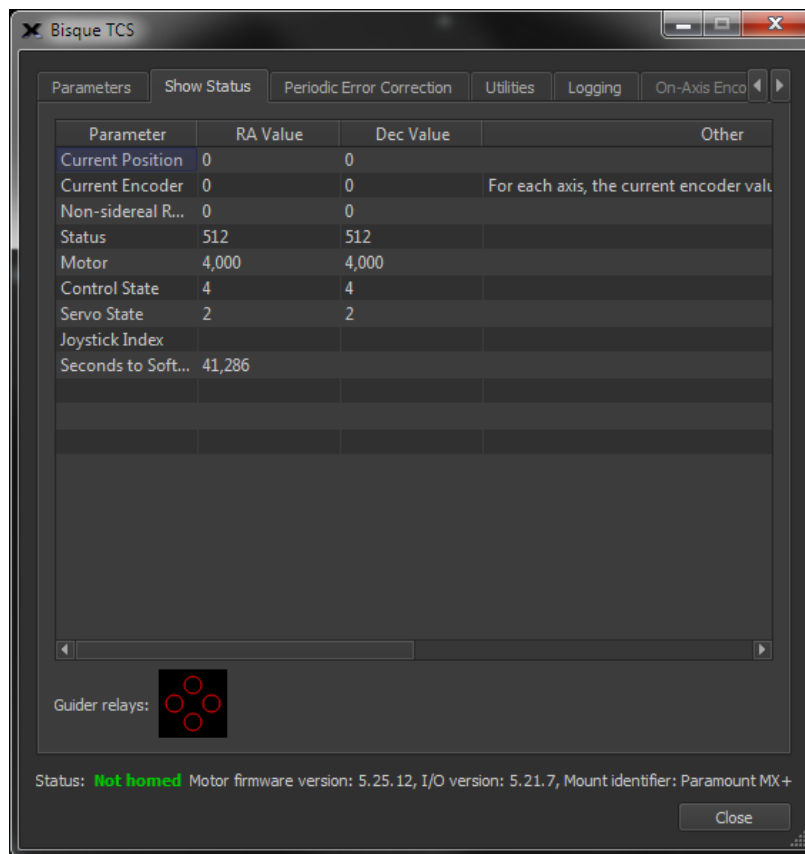

Figure 73: The Show Status tab on the Bisque TCS window.

Parameter	Description
Current Position	Shows the value of the mount's current position.
Current Encoder	Shows the current encoder position for both axes. For each axis, the current encoder value changes when mount is tracking; it remains fixed when not tracking.
Non-sidereal Rate	Shows a number that represents the incremental tracking rate (above or below the sidereal rate). When the mount is tracking at the sidereal rate, values for both RA and Dec are zero. If either rate is non-zero, the mount is tracking at a non-sidereal rate. See the Set Track Rates command in <i>TheSkyX Professional Edition User Guide</i> details about setting tracking rates.
Status	Shows an internal motor status value.
Motor	Shows the motor status.
Control State	A number that indicates the current "state" of the control system.
Servo State	A number value that indicates the current "state" of the DC Servo motor.
Joystick Index	A number that shows the joystick's index position.
Seconds to Software Limit	The total number of seconds until the mount encounters a software slew limit.

The two graphics on the bottom of the Status window show the state of the guider relays (either open or closed) and the relative position of the joystick (centered or moving the mount in a particular axis or axes).

Guider Relays

The **Guider Relays** graphic on the bottom left side of the **Show Status** tab (see Figure 73) shows four red circles (clockwise from the top) that represent North, East, South and West mount relays. The color of the circle changes when the relays are open or closed.

- A black-filled circle indicates that the relay is open so that no guider corrections are being made.
- A green-filled circle indicates that the relay in this axis is closed and guider corrections are being applied to the mount.

If the graphic shows that the relay is unexpectedly closed (for example, if there is no autoguiding taking place), here are possible causes:

- The relays on some SBIG camera models are always closed when the camera is turned off. Turn the camera on to open the relays and show black-filled circles.
- A shorted or otherwise improperly wired autoguider cable is causing unwanted guider corrections in one or more directions. Try unplugging the guider cable from the Electronics Box on the Paramount ME II, MX, or MX+, or, from both the Adaptor Panel and the Instrument Panel on the Paramount ME. If the relays are now closed, replace the guider cable.
- Corrosion or other containments are causing a short in the relay port. Try spraying electronics cleaner on both the cable and directly in the guider relay port to see if the behavior persists.

Joystick (MKS 5000 only)

The **Joystick** graphic on the bottom right side of the **Show Status** tab (see Figure 73) shows four black squares, outlined in red and represent the north, south, east and west direction controls on the joystick. The fill color of each square changes from black to green when the mount is being slewed by the joystick in that direction.

- A black-filled square indicates that the joystick is centered and the mount is not slewing via the joystick inputs.
- A green-filled square indicates that the joystick is issuing slew commands to the highlighted axis.

Note that the joystick handle can be moved diagonally so as to issue slew commands both axes at once (N, E, S, W or NE, NW or SE, SW). In this case, two adjacent squares will be green.

Periodic Error Correction Tab

The **Periodic Error Correction** tab is used to generate and manage periodic error curves for the Bisque TCS control system. The **Bisque TCS PEC Table** tab is used to retrieve, save, delete and view the periodic error correction curve. The **Compute PEC Curve** tab is used to determine the optimal periodic error curve based on mount tracking data.

The Paramount has precision worms and gears that slew the mount's axes and track the earth's relative motion compared to the stars. As the worm rotates, imperfections in the drive system (on the order of *one twenty-millionths of one inch*) introduce a predictable "back and forth" drift at the eyepiece.

This drift is called *periodic error* and is present in all worm and gear drive systems. The mount's periodic error can be virtually eliminated using *periodic error correction*. Here is an overview of the periodic error correction process. Step by step details follow.

How to Train and Apply Periodic Error Correction

1. Create a *tracking log* that records the magnitude of the mount's periodic error over three or more revolutions of the worm. See "Collecting and Using Periodic Error Tracking Data" on page 148 for details how to create a tracking log.
2. Open the tracking log in the **Compute PEC Curve** tab.
3. Fit an optimal periodic error curve to the tracking log data.

4. Save and permanently store the optimized periodic error curve to the mount's firmware.
5. Turn on the **Apply PEC Corrections** checkbox to apply periodic error corrections.

The importance of applying periodic error correction to tracking depends on several factors:

- The magnitude of the mount's periodic error. All mounts have slightly different periodic error due to machining variations. The greater the periodic error, the more noticeable the back and forth "drift" in right ascension and more elongated stars in photos.
- The scale of the imaging system. Tracking demands for an imaging system with an image scale of four arcseconds per pixel or larger are less demanding than on a system with an image scale of one arcsecond per pixel or less.
- The local seeing and weather conditions. A turbulent jet stream caused by nearby mountain ranges (here in Golden, Colorado, for example) can produce average seeing errors from three to five arcseconds per pixel and rarely better. A laminar, more stable atmosphere in regions like Florida or Southern New Mexico in the USA often produce periods of sub arcsecond seeing.

As an example of periodic error versus seeing versus image scale, if the mount's peak to peak periodic error is two arcseconds, and the local seeing conditions average three arcseconds, then the tracking error caused periodic error is *less than* the tracking errors caused by seeing conditions, so correcting the mount's periodic error is not critical.

However, if the local seeing averages one arcsecond and the optical system's image scale is one arcsecond per pixel or smaller, you want to make sure that the periodic error is as small as possible for optimal results.

TheSkyX Professional Edition is used to compute, retrieve and save a periodic error correction curve to the Bisque TCS firmware.

When the **Apply PEC Corrections** checkbox is turned on, the resulting corrected periodic error of the mount should be less than one arcsecond (usually 1 arcsecond peak to peak error or less), which is normally less than the errors introduced by local seeing conditions (typically 1-5 arcseconds, depending on the location, weather conditions, etc.).

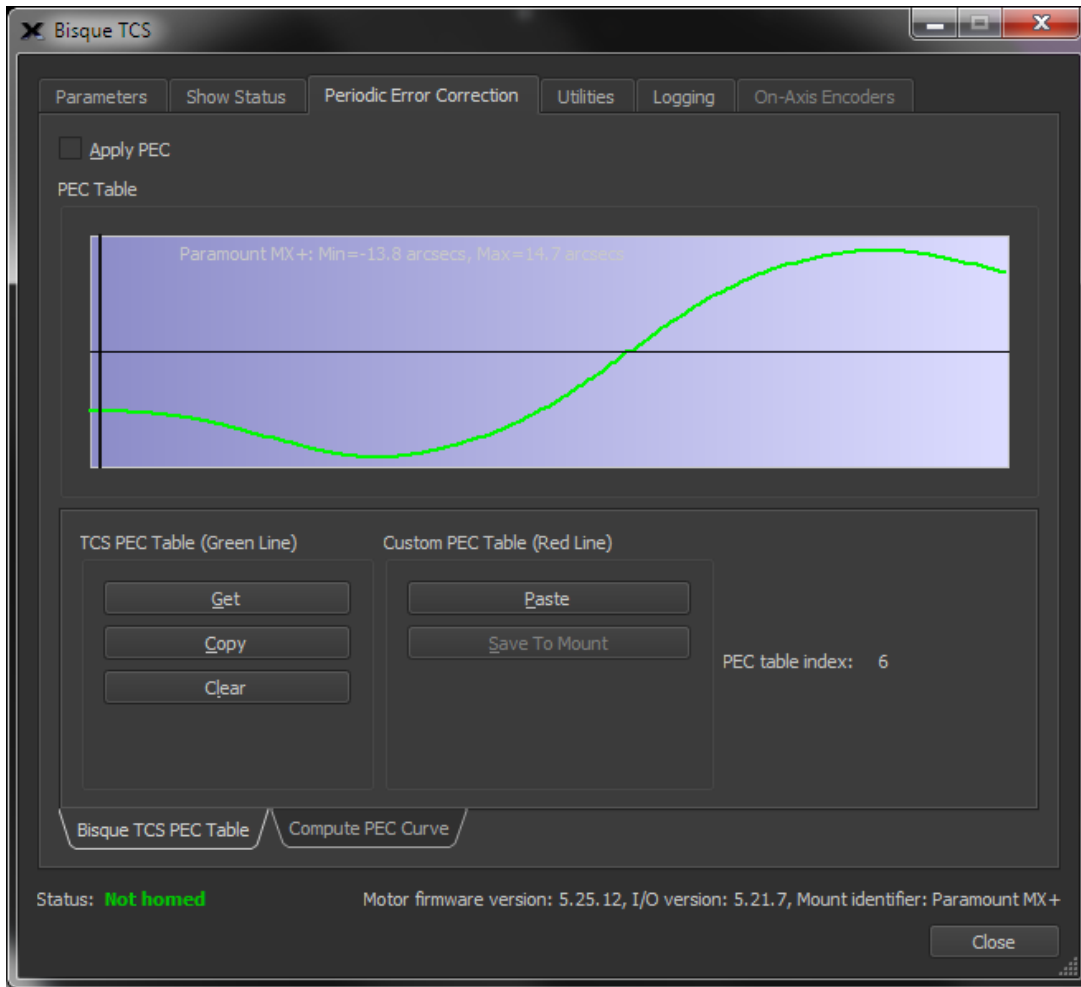

Figure 74: The Bisque TCS PEC Table tab on the Periodic Error Correction tab (Bisque TCS window).

Apply PEC Corrections

Turn this checkbox on to apply periodic error corrections during sidereal tracking. Note that periodic error correction will not be applied when tracking fast moving objects, such as spacecraft.

Bisque TCS PEC Table Tab

The **Bisque TCS PEC Table** tab on the **Periodic Error Correction** tab shows a graph of the mount’s periodic error correction table. Note that you must first retrieve or **Get** the periodic error table that is stored in the mount’s firmware. The message **No Table Present** is displayed on the graph if the periodic error data has not been retrieved from the mount, or the mount does not have a periodic error curve. The green line on the graph shows the corrections that are applied over one period of the worm. The black vertical line shows the current position of the worm in the PEC table.

The shaded purple region shows a graph of the mount’s periodic error or PEC table. The X-axis represents the time for one revolution of the worm. The Y-axis shows the magnitude of the correction at a given

worm position. The red line shows the actual periodic error correction, in arcseconds that is applied over one revolution of the worm.

Retrieve PEC Table from Control System (Get Button)

Click the **Get** button to retrieve the PEC table that has been saved to the mount's firmware. The **PEC Table** graph shows the text **Reading PEC Table...** while the data is being retrieved from the Bisque TCS.

Delete PEC Table from Control System (Delete Button)

Click the **Delete** button to permanently delete the PEC table that is stored in the Bisque TCS. The PEC Table graph shows the text **Deleting PEC Table...** while the data is being deleted from the Bisque TCS.

Paste Custom PEC Table (Paste Button)

Retrieve the periodic error correction table values from the Clipboard and display them on the PEC graph.

Copy Custom PEC Table (Copy Button)

Click this button to copy the current periodic error correction table values from the graph to the Clipboard in ASCII text format. The format of the ASCII text data is two space delimited columns:

- The zero-based PEC table index.
- The relative mount-specific periodic error correction.

Column values must be separated by a minimum of one space character (no tabs), with carriage return line feed pairs at the end of the line.

The following text shows an example ASCII PEC table.

```
0<0x20><0x20><0x20>-9<CR><LF>
1  -9<CR><LF>
2  -9<CR><LF>
3 -10<CR><LF>
4 -10<CR><LF>
5 -10<CR><LF>
6 -10<CR><LF>
7 -11<CR><LF>
8 -11<CR><LF>
9 -11<CR><LF>
10 -11<CR><LF>
. . .
1248 -8<CR><LF>
1249 -9<CR><LF>
```

PEC Table Index

This number represents the position of the worm in the PEC correction table.

Model	PEC Index Values
ME	0 – 1249
MEII	0 – 1124
MX	0 – 999
MXG	0 – 499
MYT	0 – 499

Compute PEC Curve Tab

The table below lists the maximum peak-to-peak periodic error *specification* for each model Paramount mount.

Model	Maximum Peak to Peak Periodic Error (arcseconds)
ME	7
MEII	7
MX	7
MXG	7
MYT	7

This periodic error can be corrected (see “Collecting and Using Periodic Error Tracking Data” on page 148) so that the *corrected periodic error* is below errors introduced by local seeing. In other words, the tracking error introduced by mechanical periodic error is “in the noise” and not readily detectable at the eyepiece or in the measured FWHM of stars on a CCD photo.

Under all but extremely exceptional seeing conditions, measuring periodic error can be difficult, even using an autoguider, because the random errors caused by local seeing conditions can be larger than the actual periodic error of the worm and gear.

The **Compute PEC Curve** tab offers an extremely powerful algorithm that can be used to precisely determine the mount’s periodic error, independent of the errors introduced by local seeing conditions.



Figure 75: The Compute PEC Curve tab on the Periodic Error Correction tab (Bisque TCS window).

PEC Table Graph

The yellow shaded region can be used to show a graph of the tracking log data, the “best fit” curve to that data and the actual periodic error curve derived from the best fit curve that is stored to the Bisque TCS flash memory.

Use the mouse scroll wheel to adjust the relative scale of the graph. Scrolling forward expands the scale on the graph, scrolling backward magnifies the graph.

Image Scale

Enter the image scale of the optical system, in arcseconds per pixel. Image scale is critical for computing the correct periodic error from the tracking log data. If you are unsure of the photo’s image scale, use *TheSkyX Professional Edition’s* Image Link feature to compute it for you.

Data Was Collected When Telescope Was Pointing West

Turn this checkbox on if the tracking log data was collected when the telescope was pointing to the West side of the meridian.

Raw Tracking Data

Turn on this checkbox to show the positions of the star's centroid from the tracking log data as a light gray line.

Curve Fit to Tracking Data

Turn on this checkbox to show the optimal periodic error curve computed by clicking the **Fit** button.

Periodic Error Curve for Bisque TCS

Turn on this checkbox to show a graph of the periodic error curve to be saved to the Bisque TCS control system's flash memory. Turning this checkbox on automatically hides the raw and fit graphs.

Open Tracking Log

Click this button to open a tracking log that was generated by the *Camera Add On*.

Fit

Click this button to compute and display the graph of an optimal periodic error curve for the tracking log data.

Clear

Click this button to remove or delete the existing tracking log.

Save To Mount

Click this button to save the fit periodic error curve to the Bisque TCS.

Collecting and Using Periodic Error Tracking Data

Follow the steps below to obtain and apply the optimal periodic error correction curve for your mount.

Step 1 Collect the Tracking Log

The first step is to obtain a *tracking log* for your Paramount. A tracking log is a record of the position of a star's centroid over four or more revolutions of the worm, without making *any* tracking corrections to the mount's position. (Technically, a tracking log is merely an autoguider log without any guider corrections.)

In order to successfully acquire a tracking log, you must place a star on the detector, and that star must stay inside a "tracking box" for ten to fifteen minutes without making any corrections to the mount's position (for several periods of the worm) so that the position of the star during that time can be recorded.

When choosing a star, the best declination is 0° , where the periodic error will cause the largest effect in sky angle, but anywhere within $\pm 26^\circ$ will be at least 90% as good. Somewhere close to the meridian gives the highest altitude and hence the best seeing.

The Paramount, *TheSkyX Professional Edition* and the *Camera Add On* must be configured to:

- Turn off periodic error corrections (page 144).
- Turn off or disable autoguiding (see below).
- Turn off *TPoint Add On* modeling (see below).
- Turn off tracking corrections from ProTrack (see below).
- Set the mount to track at the sidereal tracking rate (page 124).
- Remove, turn off or disable adaptive optics devices.
- Unplug all guider cables from the mount.
- Unplug the mount's joystick or hand paddle.
- Physically rotate the CCD camera to orient it [north up](#).

Remember, the tracking log cannot be acquired when guider corrections are made; instead the star's *uncorrected* position must be recorded over time as the mount tracks at the sidereal rate. Collecting tracking data is typically less demanding than autoguiding since mount calibration is not required.

The resulting tracking log file (named "autoguider.log" since this log is normally used to log autoguiding data) allows *TheSkyX Professional Edition* to determine the best fit periodic error curve for your mount.

- On the Paramount**
1. Unplug the autoguider cable from the mount's Electronics box (Paramount ME II, Paramount MX, Paramount MX+ and Paramount MYT), Adaptor Panel and Instrument Panel (Paramount ME).
 2. Unplug the joystick from the Adaptor Panel (Paramount ME) or the hand paddle from the Electronics Box (Paramount ME II, Paramount MX, Paramount MX+ and Paramount MYT).
 3. Make sure your camera is rotated approximately north "up":

Camera Orientation Requirements

Make sure the CCD camera is oriented correctly. The camera's detector must be oriented so that telescope motion in right ascension closely corresponds to x-axis motion on the detector (see diagram below). If the detector is not oriented properly, then the maximum magnitude of the periodic error is not recorded. Note that precise orientation is not crucial; the detector should be within 5 degrees of North (or South).

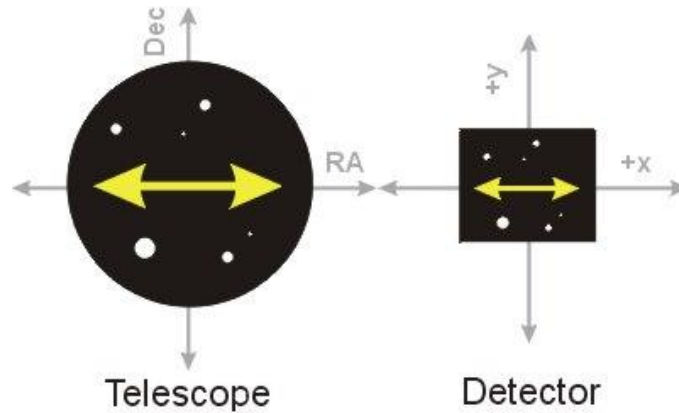

Figure 76: The telescope's orientation versus CCD detector orientation.

**From TheSkyX
Professional Edition**

1. Choose the **Connect** command from the **Telescope** menu to connect to the Paramount.
2. Turn off the **Apply Pointing Corrections** checkbox on the **Setup** tab of the **TPoint Add On** window. (Click **Telescope > TPoint Add On** to show the **TPoint Add On** window.)
3. Turn off the **Activate ProTrack** checkbox on the **ProTrack** tab of the **TPoint Add On** window.
4. Open the **Bisque TCS** window (see page 125).
5. Click the **Periodic Error Correction** tab.
6. Turn off the **Apply PEC Corrections** checkbox.
7. Click **OK**.

Note that you can use your autoguider or imaging camera to create the tracking log. We recommend using the larger imaging camera to make the process easier.

1. Click the **Telescope Setup** command from the **Telescope** window and expand **Autoguider**.
2. Double-click **Camera** and select your main imaging camera imager for the detector that will collect the tracking log data.
3. **DISABLE ALL AUTOGUIDING CORRECTIONS IN BOTH AXES**. Click the **Autoguider** tab. (Click the **Autoguider** command from the **Display** menu if this window is not visible.)
4. On the **Autoguide** tab, click the **Setup...** button.
5. On the **Relay Settings** tab, turn off the **X Plus, X Minus, Y Plus, Y Minus** checkboxes following the **Relay Enabled** text (Figure 77). Turning these options off prevents the **Camera**

Add On from making corrections to the position of the guide star.

6. Click **OK**.

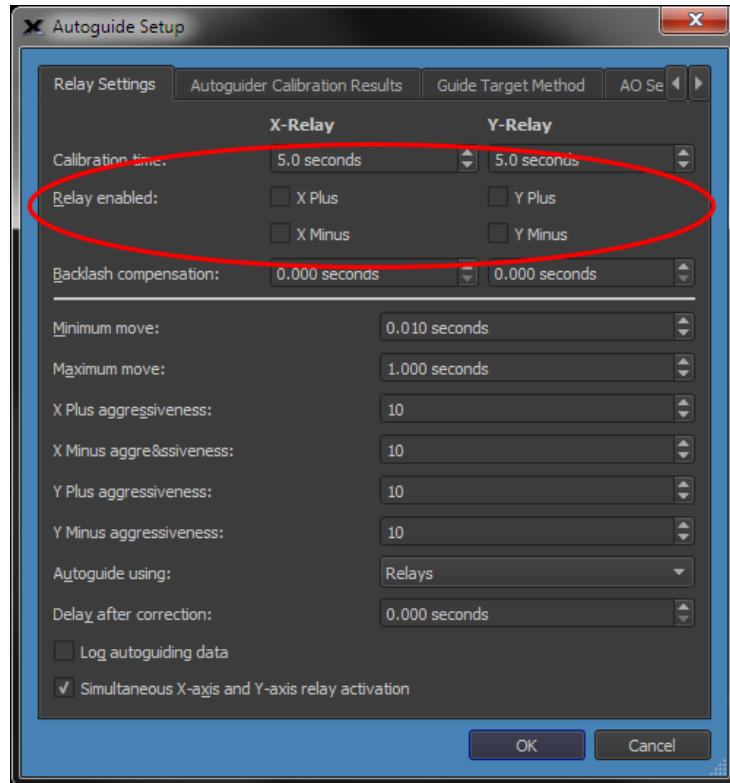

Figure 77: The *Relay* tab on the Camera Add On's *Autoguide Setup* window.

7. On the **Autoguide** tab, click the **Clear Log** button to delete the autoguider log file. Click **Yes** to confirm deletion of the file. (You will not be prompted when no log file exists).
8. Turn on the **Log Autoguiding** checkbox. Autoguiding logs are saved to a folder that is named using the current date (for example, *January 01 2018*) in the *Autoguider* (or *Imager* folder, depending on which camera was used to collect the tracking log) folder of the *CameraAutoSave* the operating system-specific *Application Support Files* folder. See TheSkyX Professional Edition User Guide for details about the location of this folder on your operating system.
9. Locate an appropriate guide star and then click the **Autoguide** button to begin collecting tracking log data.

Periodic Error Tracking Data Collection Recommendations

- The guide star should be a relative bright star on the west side of the meridian, near 0 degrees declination and near the meridian (within a few degrees).
- Track the star for at least *four* periods of the worm; 10 minutes using a Paramount ME or Paramount ME II, about 15 minutes 30 seconds using the Paramount MX and Paramount MX+ and about 20 minutes for the Paramount MYT.
- Make sure to compute and record the image scale for your imaging system. It is required for the next step.

Step 2 Generate the PEC Curve

After the position of the guide star has been logged for at least four periods of the worm, you are ready to generate the PEC curve and save it to the control system's "PEC table".

1. From *TheSkyX Professional Edition*, connect to the Paramount by clicking the **Connect** command on the **Telescope** menu.
2. Open the **Bisque TCS** window (see page 125).
3. Click the **Periodic Error Correction** tab.
4. Click the **Open Tracking Log** button.
5. Select the tracking log file and click **Open**. The "raw" periodic error data shown on Figure 78. Your results will vary, but the noisy-looking data is normal. For this example, each pixel of motion recorded in the tracking log equates to one arcsecond of error. The maximum and minimum error values are displayed on the right side of the graph (these values are not easily visible in Figure 78).

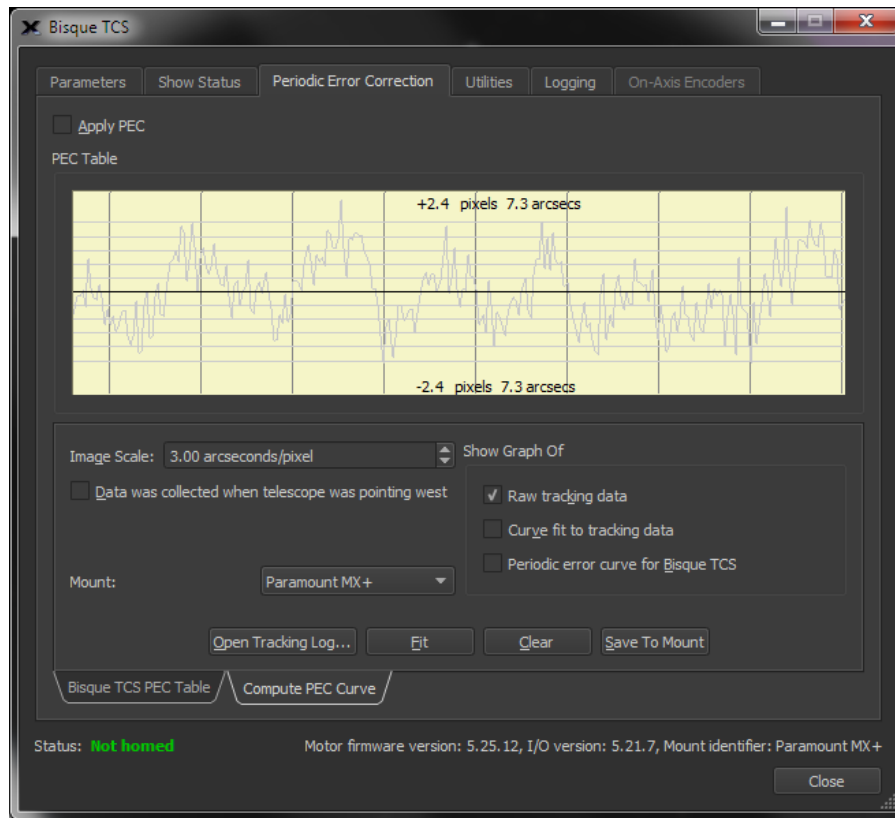

Figure 78: Graph of tracking log data.

5. Enter the image scale of your optical system in arcseconds per pixel. If you do not know the scale, use *TheSkyX Professional Edition's* Image Link to determine this value.
6. Turn on the **PEC Data Was Collected When Telescope Was Pointing West** checkbox if the tracking log data was collected using a star on the west of the meridian. This information is needed to determine the phase of the error. Turning this checkbox on when the mount was pointing to the east while recording the tracking log results in a “doubling” of the periodic error. So, if the periodic error is higher after applying PEC, chances are this is the cause. Simply turn off the check box, and proceed with the next step.
7. Click the **Fit** button. The **PEC Table** graph is updated with the optimal periodic error curve for your mount.

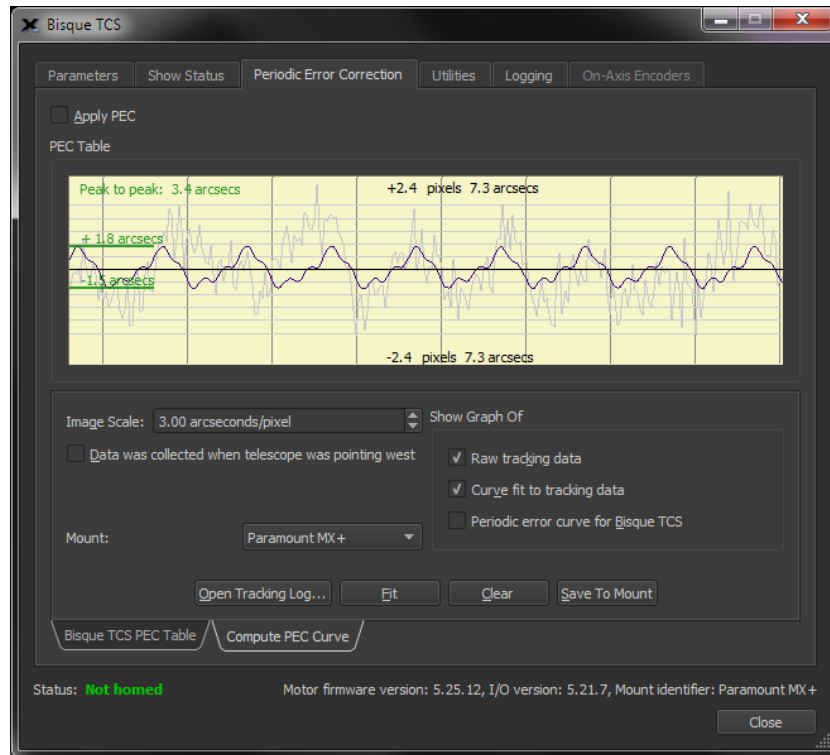

Figure 79: After clicking the Fit button, the graphs show both the raw and “fitted” data.

8. Click the **Periodic Error Curve for Bisque TCS** checkbox to display the graph of the curve that will be transferred to the Paramount control system's PEC table.

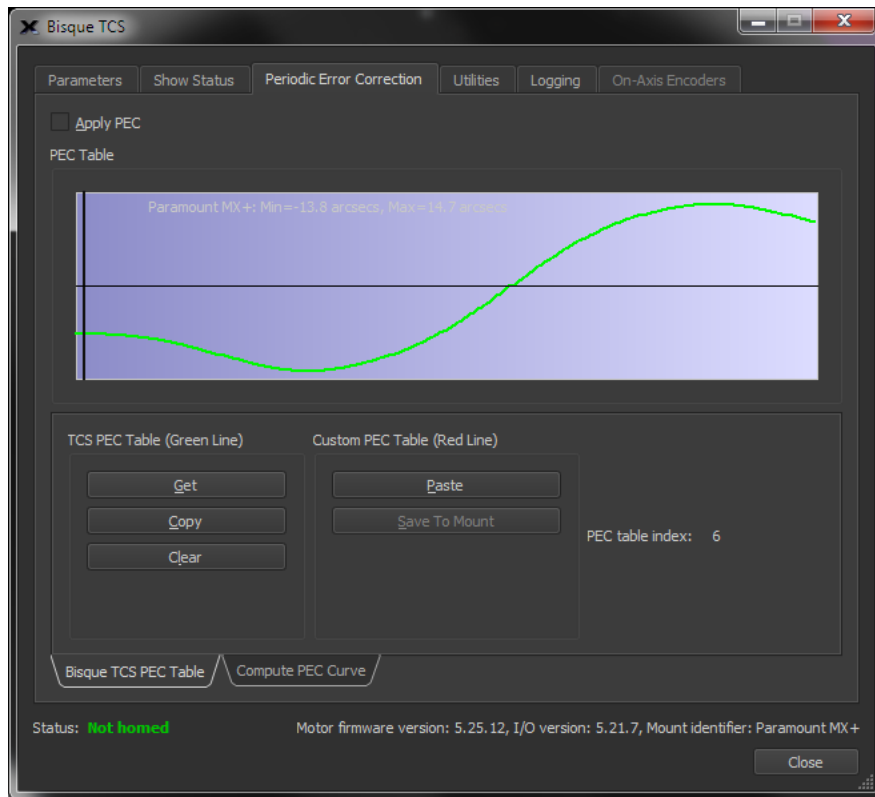

Figure 80: The periodic error curve should be saved to the mount's PEC table.

The above PEC curve is not "smooth" by design. The graph shows the minimum resolution for mount "moves" (approximately 0.01 arcseconds) when applying periodic error corrections. This data is saved to the control system's Flash RAM, and will be always be used to correct the mount's periodic error (provided the **Apply PEC Corrections** checkbox is turned on).

Step 3 Save the PEC Curve to the Paramount Firmware

Click the **Save** button to save this curve into the Paramount's PEC table (that is, the curve is saved in the control system's flash RAM for permanent use).

Step 4 Apply PEC Corrections

1. From *TheSkyX Professional Edition*, connect to the Paramount by clicking the **Connect** command on the **Telescope** menu.
2. Open the **Bisque TCS** window (see page 125).
3. Click the **Periodic Error Correction** tab.
4. Turn on the **Apply PEC Corrections** checkbox.

Your Paramount will now use the optimal PEC curve for the errors in your worm/gear.

Utilities Tab

The Utilities tab provides access to many high-level control system settings.

Hemisphere Setup

Click the **Hemisphere Setup** text on the right side of the **Utilities** tab to configure the mount's tracking direction and show hemisphere-specific mount status. (The home sensor values are shown only when the mount is connected.)

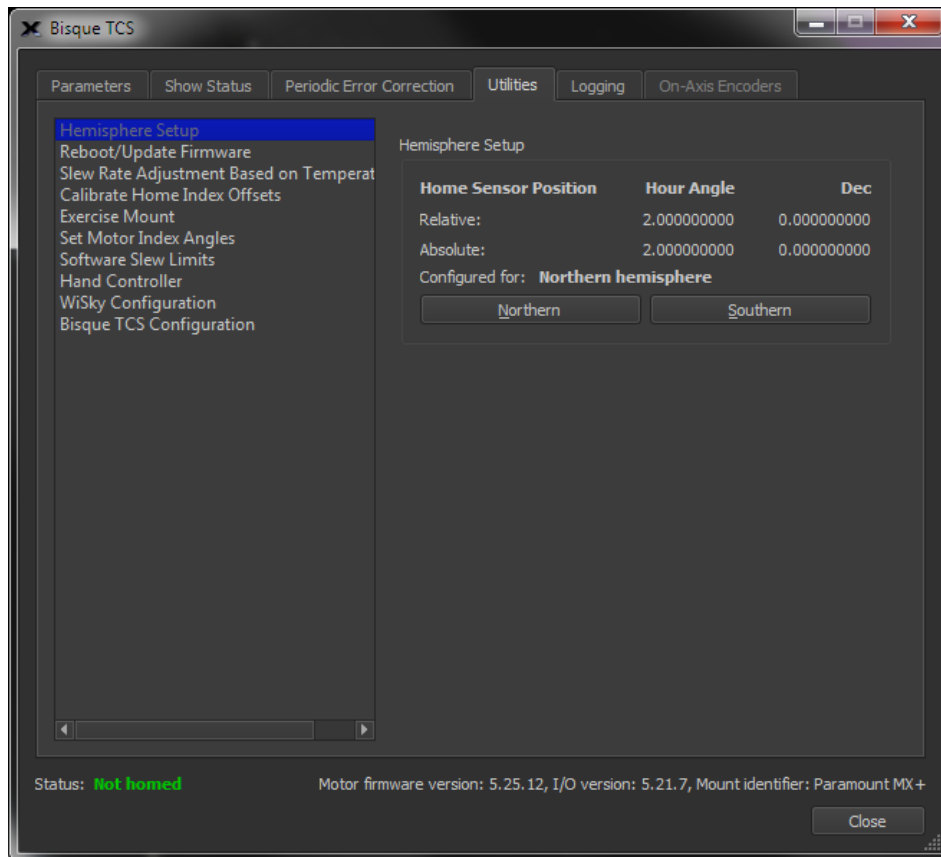

Figure 81: Example hemisphere settings for the northern hemisphere.

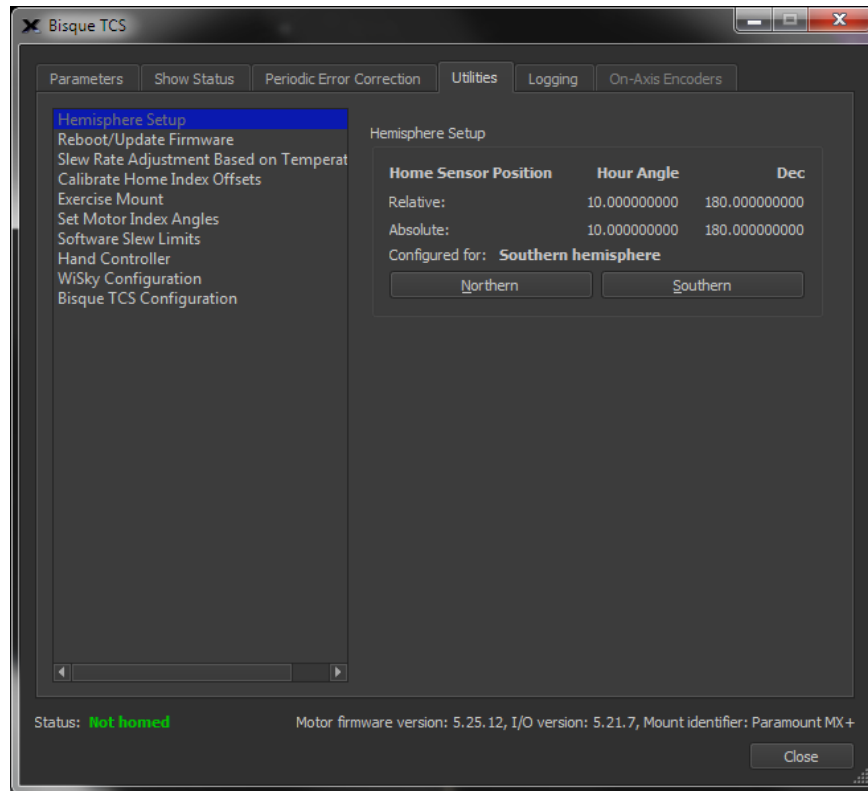

Figure 82: Example hemisphere settings for the southern hemisphere.

Relative Home Sensor Position (Hour Angle)

Shows the hour angle of the homing sensor based on the mount's synchronization information.

Relative Home Sensor Position (Declination)

Shows the declination of the homing sensor based on the mount's synchronization information.

Absolute Home Sensor Position (Hour Angle)

This text box shows the mechanically fixed hour angle of the homing sensor. This value cannot be changed for the Paramount ME, Paramount ME II, Paramount MX or Paramount MX+ mounts and is always HA = 2.0 and Dec = 0.0.

Absolute Home Sensor Position (Declination)

This text box shows the mechanically fixed declination of the homing sensor. This value cannot be changed for the Paramount ME, Paramount ME II, Paramount MX or Paramount MX+ mounts.

See the "Advanced Parameters" on page 129 for a discussion of the differences between the relative and absolute homing position.



Note on Southern Hemisphere Hour Angle and Declination Values

Figure 82 shows the home sensor's *absolute position* and *relative position* for the southern hemisphere. Both values reflect the *mechanical position of the mount*, not actual sky

coordinates. This convention allows *TheSkyX Professional Edition* to know which side of the pier the OTA is on.

To convert the mechanical hour angle to the sky hour angle, subtract 12. Take 180 minus the declination to convert the mechanical declination to sky declination.

Configured For Text Box

This text box shows the current hemisphere configuration.

Northern and Southern Buttons

The Northern and Southern buttons are used to configure the mount for operation in either hemisphere. The default configuration is for the northern hemisphere. When the mount is located in the southern hemisphere, click the **Southern** button so that the sidereal tracking direction is reversed and the homing sensor positions can be updated. The control system is automatically “rebooted” so that these changes take effect.

Reboot/Update Firmware

If control system is emitting continuous beeps (for example the mount has encountered a fixed object like the side of the pier so that the motors have stopped) the control system should be restarted and then homed (page 21). To restart the control system, click the **Reboot/Update Firmware** text on the right side of the **Utilities** tab, then click the **Normal** button under **Reboot Bisque TCS** on the left side of this window.

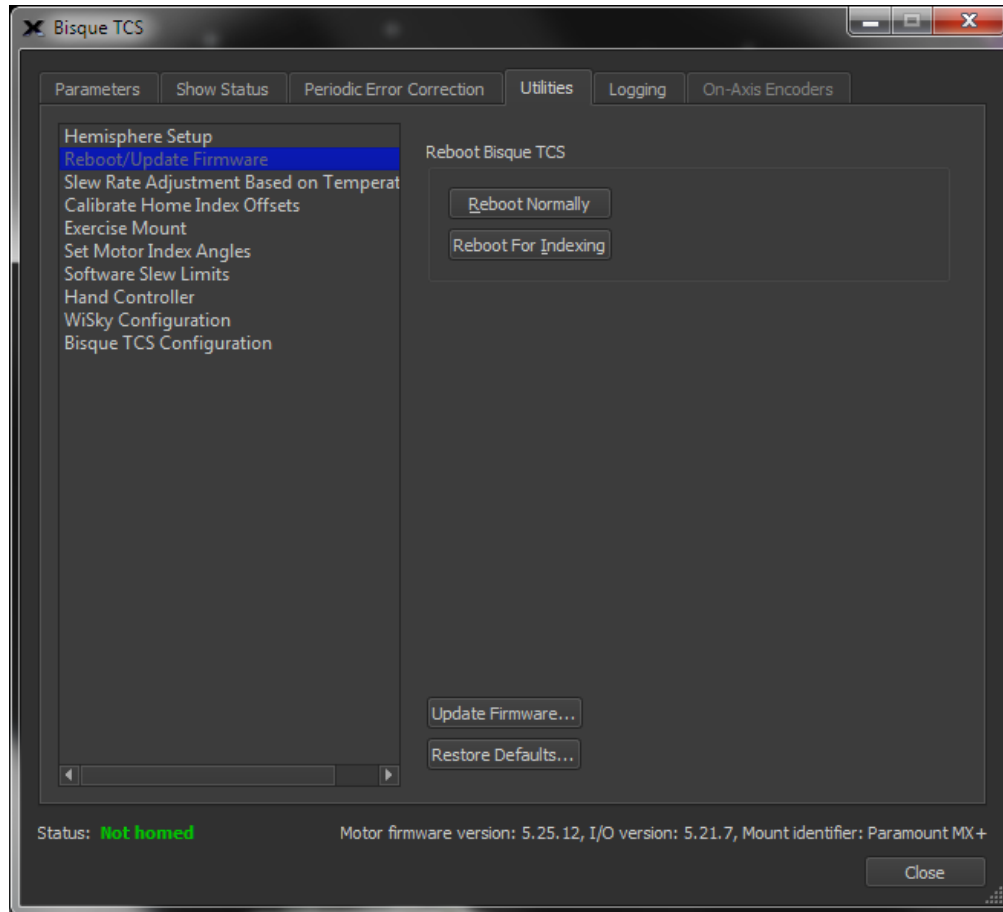

Figure 83: The Reboot/Update Firmware settings on the Utilities tab.

Reboot Normally Normal

Click this button, then click the **Yes** button on the confirmation window to restart the control system for normal operation.

Reboot For Indexing

Click this button to restart the control system when updating the mount's motor index angles.

Control System Firmware Updates

While every attempt is made to apply the latest firmware to the MKS 5000 control system before the mount is shipped, Software Bisque may periodically release newer versions. The current motor firmware version is listed on the bottom left of the Bisque TCS window.



Do not attempt to reinstall the same version of Paramount firmware unless specifically instructed to do so by Software Bisque.



You must register your Paramount ME II, Paramount MX, Paramount MX+ or Paramount MYT serial number to access to the MKS 5000 firmware updates. (Access to these downloadable files will be denied otherwise.)

Updating the Firmware (Update Firmware Button)

MKS 5000 firmware updates, when available, can be downloaded from the Downloads page on the Software Bisque web site.

Step by Step *MKS 5000 Firmware Update Instructions*

1. Click the **Check for Updates** command from *TheSkyX Professional Edition's Help* menu and install the latest update or daily build if necessary.
2. Visit the Software Bisque web site at www.bisque.com and sign in.
3. If you have not already done so, register your Paramount serial number at: www.bisque.com/register. Registering your serial number gives your account permission to access to the MKS 5000 firmware downloads. Access is denied otherwise.
4. On the Software Bisque web site, click the **Downloads** link, then click the **MKS 5000** link in the left column (under the **Browse Downloads** text). Immediately beneath the **MKS 5000** link, click the **Firmware Updates** link. If these links are “missing” it means there is no Paramount serial number registered for the current Software Bisque web account. MKS 5000 firmware updates, when available, are listed in the center of the web page.
5. From here, follow the operating system-specific instructions below:



Mac Instructions

- a. Click the **Paramount MKS 5000 Latest Mac Firmware Installer** link under the **Name** column near the center of the page.
- b. Click the **Download** link on the left side of this page to download the **MKS 5000 Firmware Disc Image**. This file is saved to your *Downloads* folder.
- c. Open the Downloads folder, then double-click **MKS 5000 Firmware Disc Image** to open or “mount” this disc image.
- d. Double-click the **Install MKS 5000 Firmware** icon. Once completed, the latest firmware files have been copied to your computer.



Windows Instructions

- a. Click the **Paramount MKS 5000 Latest Windows Firmware Installer** link under the **Name** column near the center of the page.
- b. Click the **Download** link on the left side of this page to download the file named **MKS 5000 Latest Windows Firmware Installer.exe**.
- c. Double-click **MKS 5000 Latest Windows Firmware Installer.exe** to run to. Complete the installation process to copy the necessary firmware files to your computer.

6. From *TheSkyX Professional Edition*, choose the **Connect** command from the **Telescope** menu.
7. On the **Telescope** window, click the **Bisque TCS** command on the **Tools** pop-up menu.

8. On the **Bisque TCS** window, click the **Utilities** tab.
9. Highlight the **Reboot/Update Firmware** text in the left column of the **Utilities** tab.
10. Click the **Update Firmware** button.

The MKS 5000 motor controller firmware will now be updated to the latest version. Please verify this is so by comparing the firmware versions listed on the bottom of the Bisque TCS window with the firmware versions listed on the Paramount MKS 5000 Latest Firmware web pages. If the update was performed correctly, the versions *must be* identical.

Step by Step MKS 4000 Motor Firmware Update Instructions (Windows)

1. Click the **Check for Updates** command from *TheSkyX Professional Edition's Help* menu and install the latest update, if necessary.
2. Visit the Software Bisque web site at www.bisque.com and sign in, if necessary.
3. On the Software Bisque web site, click the **Downloads** link, then click the **Classic Windows Installers and Updaters** link in the left column of this page.
4. Click the **Paramount ME and MKS 4000 USB Driver and Utilities** link in the left column of this page.
5. Near the center of the page, click **MKS 4000 Firmware Version X.Y.Z** where x, y and z are numbers that represent the firmware version.
6. Click the Download link on the **MKS 4000 Firmware Version X.Y.Z** page.
7. Most browsers offer an option to save the file to be downloaded to a folder on your computer. When prompted to save the file, navigate to *TheSkyX's* Application Support Files folder.
8. From *TheSkyX Professional Edition*, choose the **Connect** command from the **Telescope** menu.
9. On the **Telescope** window, click the **Bisque TCS** command on the **Tools** pop-up menu.
10. On the **Bisque TCS** window, click the **Utilities** tab.
11. Select the **Reboot/Update Firmware** text in the left column.
12. Click the **Update Firmware** button.

The MKS 4000 motor controller firmware should now be updated to the latest version. Make sure this is the case by comparing the firmware version listed on the bottom of the Bisque TCS window with the firmware version listed on the MKS 4000 Motor Controller Firmware Latest Version on the Downloads page. If the update was performed correctly, the two versions will match.

Browse for Motor Firmware File

Click this button to select the motor firmware update file.

Navigate to the folder where the motor firmware update file was saved, select the file name and then click the **Open** button. A message appears when update is completed. At this point turn the power to the mount off, then back on to complete the process.

Restore Defaults

Click this button to restore the default Bisque TCS settings (page 137).

Slew Rate Adjustment Based On Temperature

The Paramount’s slew rate is automatically lowered when the ambient temperature drops below this value. (Lowering the slew rate provides more torque to the servomotors. This additional torque can minimize potential motor stalls from increased frictional forces at colder temperatures.)

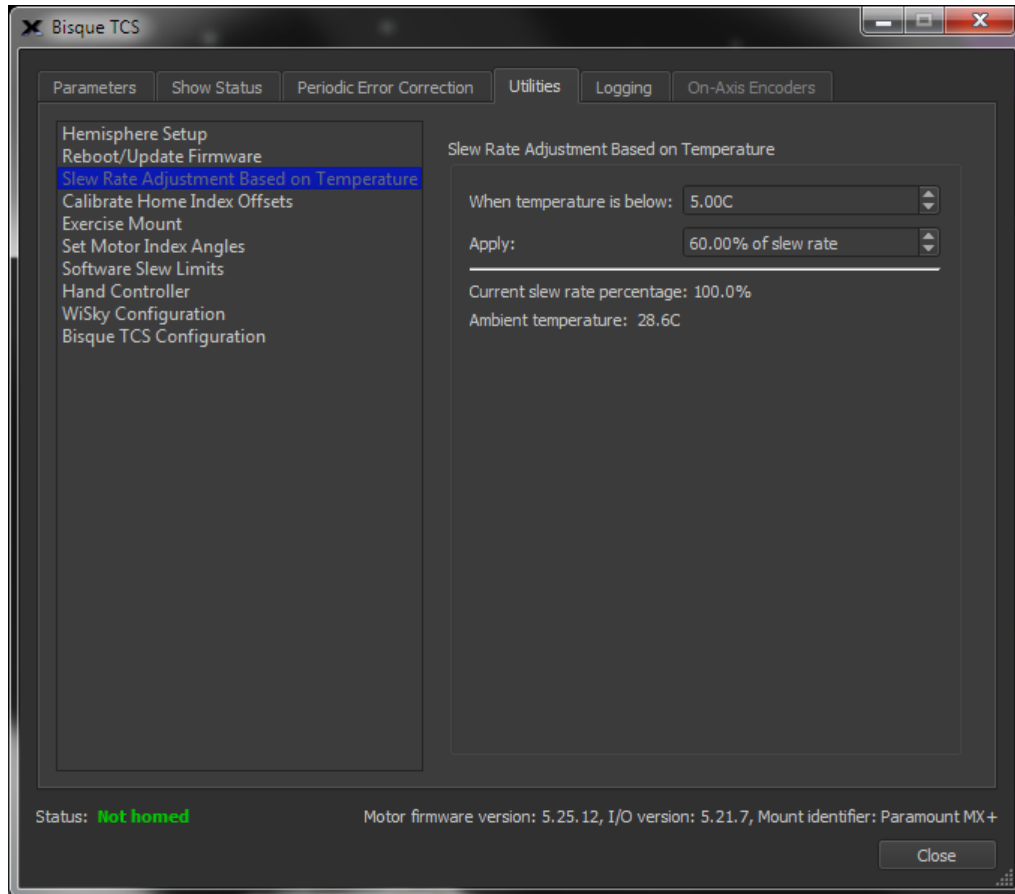

Figure 84: The Slew Rate Adjustment Based on Temperature settings on the Utilities tab.

Click ***Slew Rate Adjustment Based On Temperature*** on the right side of the ***Utilities*** tab to change the maximum slew rate and the temperature below which this slew rate is applied.

When the Temperature Is Below (C)

Enter the temperature, in degrees Celsius, below which the maximum slew rate of the mount will be reduced.

Apply (Percentage of Slew Rate)

Enter the percentage of the maximum slew rate to apply at lower temperatures.

Suppose the slew rate is set at 2 degrees per second for “normal operating temperatures”. Then, based on the values in Figure 84, when the temperature drops below 0C the slew rate is set to 60 percent of 2 degrees per second, or 1.2 degrees per second.

Current Slew Rate Percentage

This text shows the current temperature-adjusted slew rate percentage. A value of 100 percent means the temperature inside the mount is above the ***When the Temperature Is Below*** value.

Ambient Temperature

Shows the ambient temperature measured by the mount's internal temperature sensor.

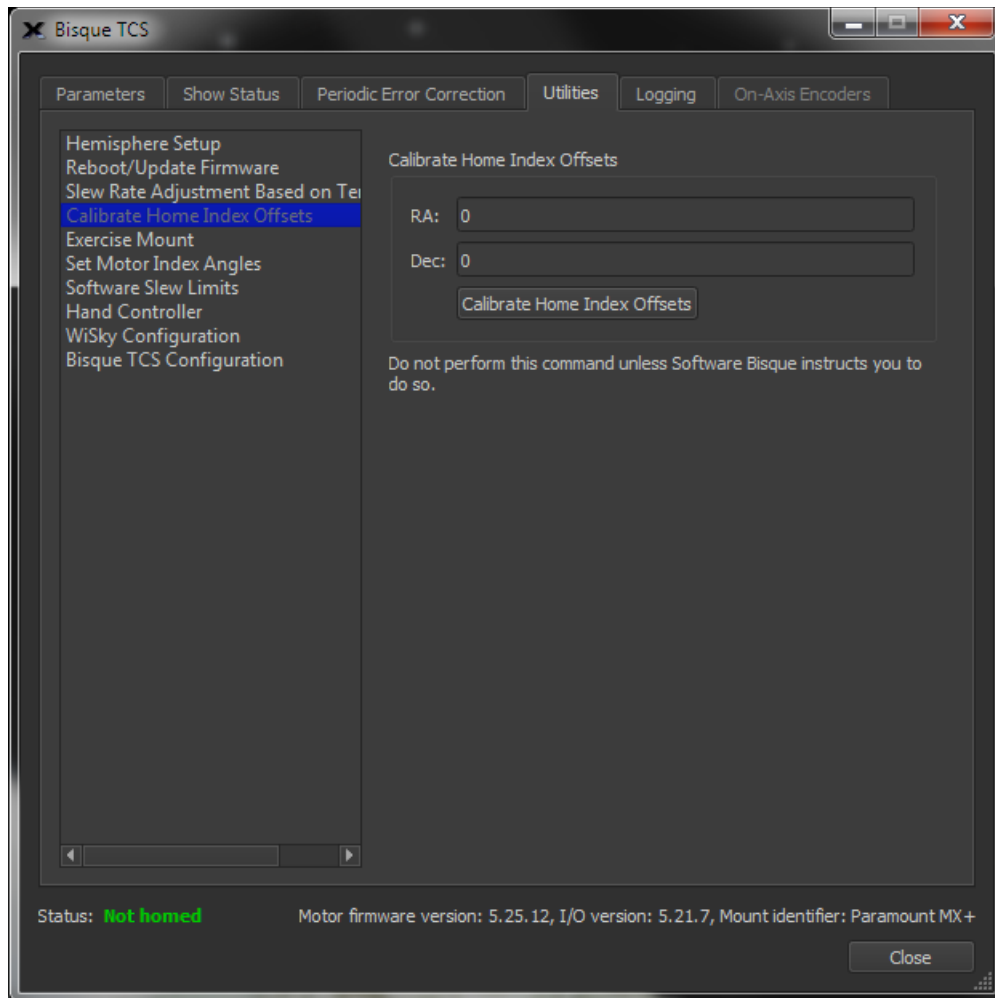

Figure 85: The Calibrate Home Index Offsets pane.

Calibrate Home Index Offsets

Please do not use these controls unless specifically instructed to do so by Software Bisque.

In rare cases, the home position may not be consistent due to small changes in the mechanical position of the home sensor and homing mark caused by temperature variations. In this case, the home position can differ by one turn of the motor when the mount is homed (from 3 to 6 arcminutes, depending on mount model and axis).

These controls measure the home position offset that insures that small mechanical motions due to temperature changes do not cause the home position to differ. The measured offset is saved to the mounts flash memory and applied to subsequent Find Home commands. After calibrating the home index offsets, it is possible the axis will home to a slightly different mechanical position than before the calibration (by one motor turn) so a TPoint pointing recalibration should be performed afterward (a complete pointing calibration is not required).

Measure RA

Click this button to measure the home index offset on the right ascension axis. This value will be applied when the Find Home command (page 124) is issued.

Measure Dec

Click this button to measure the home index offset on the declination axis.

Exercise Mount

Every Paramount undergoes a factory “run in” or exercise procedure that slews the mount between the software slew limits to ensure that the gear train, motors and electronic systems are functioning normally.

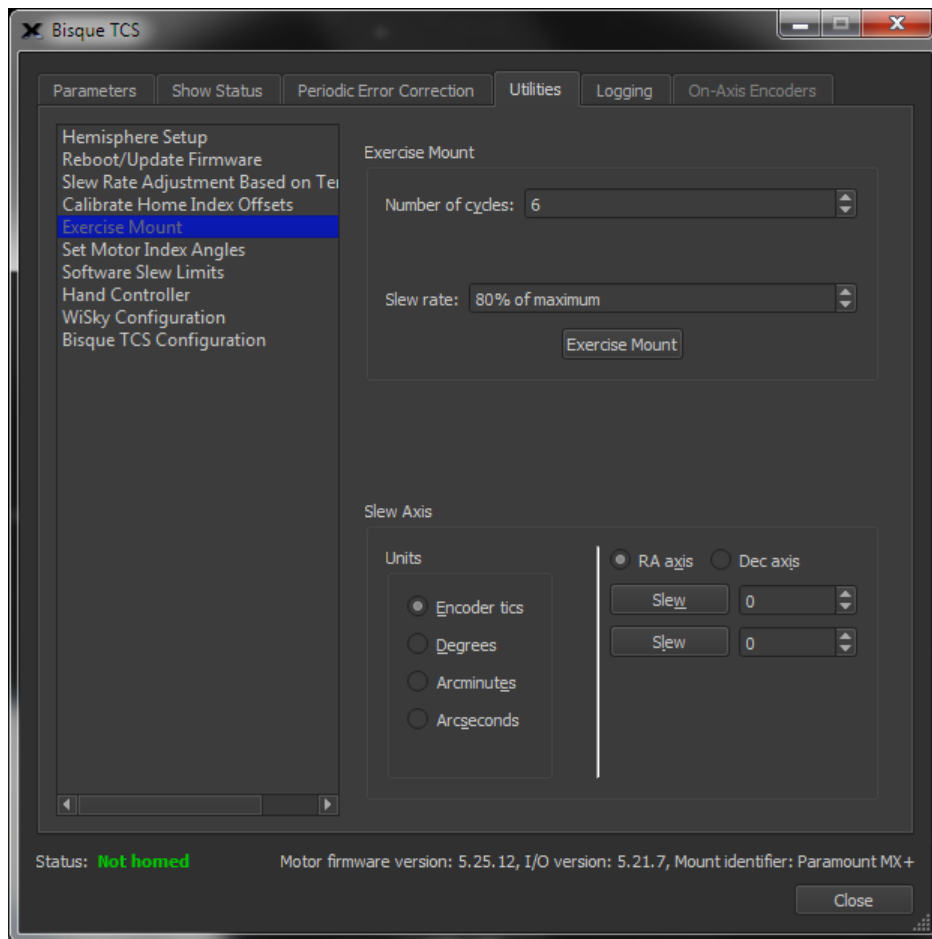

Figure 86: The Exercise Mount settings window on the Utilities tab.

You may wish to exercise the mount after the gears have been re-lubricated, or after installing through the mount cabling to make sure there are no stalling issues when the mount slews from slew limit to slew limit in both axes.

- Exercising slews both mount axes from limit to limit at the current **Slew Rate**, specified as a percentage of the maximum slew rate.
- The telescope cross hairs displayed on the Sky Chart will not follow the position of the telescope during the exercise process.

Number of Cycles

Enter the number of times to slew the mount between the software limits.

Slew Rate

Enter the rate, as a percentage of the mount's maximum slew rate, at which the mount is slewed during the exercise process.

Exercise Mount/Abort

Click this button to begin exercising the mount. While the mount is slewing, the text changes to **Abort**. Click **Abort** to end the exercise process.

Slew Axis Settings

These settings can be used to slew the RA or Dec axis using different four different "slew units".

Units

Enter the unit of measurement to slew the selected axis.

- **Encoder Tics** specifies the smallest division or angular rotation of the DC servo motor. The relative angular size of a Paramount encoder tic is one third of one arcsecond.
- **Degrees** slews the mount in angular degrees.
- **Arcminutes** slews the mount in arcminutes.
- **Arcseconds** slews the mount in arcseconds.

Slew

After entering the number of units to slew the mount in the adjacent text box, click the **Slew** button to perform the slew.

By design, two **Slew** buttons and two unit input text boxes appear so that slews using two different units can be performed.

Motor Index Angles

The MKS control system use a *motor index angle* number stored in the control system's firmware to properly initialization the DC servo motors. The **Motor Index Angle** settings allow the control system to measure and record these angles.

Measuring and retrieving index angles is required when installing a new motor or a new control system on a Paramount, only. Do not attempt to change or set the firmware's motor index angles otherwise.

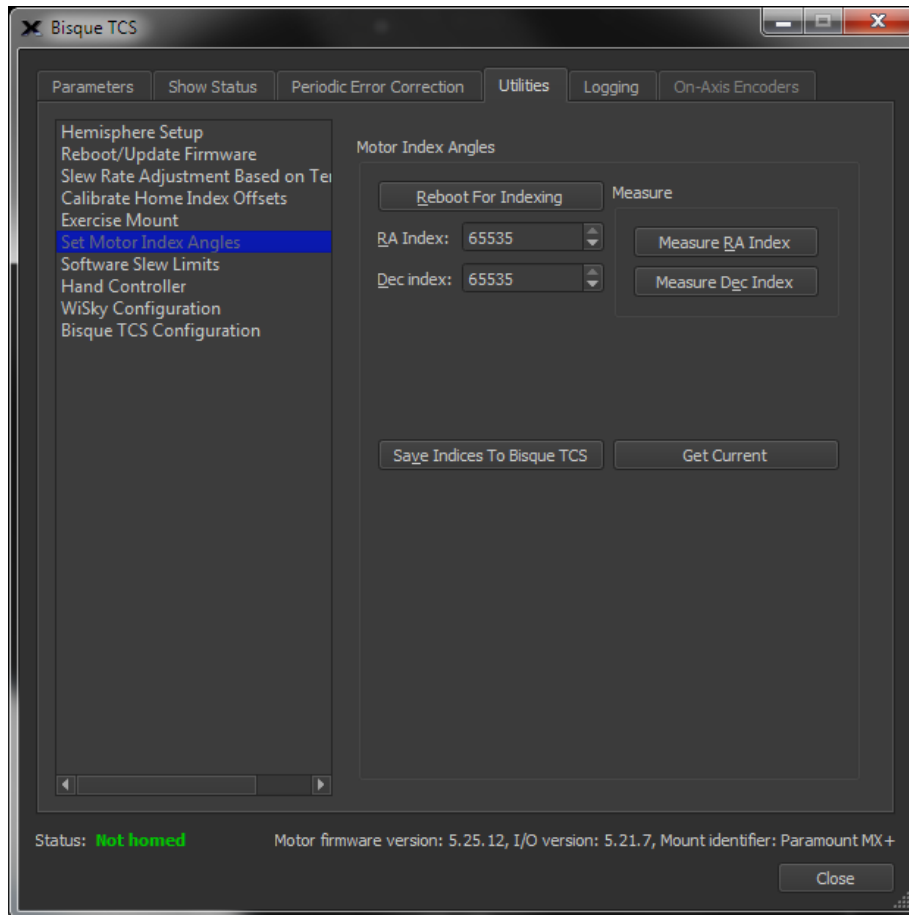

Figure 87: The Set Motor Index Angles settings on the Utilities tab.

Reboot For Indexing

Click this button to restart the Bisque TCS so that DC servomotor's unique *motor index angle* can be measured.

RA Index

Enter the motor index angle for the right ascension motor.

Dec Index

Enter the motor index angle for the declination motor.

Measure RA (RA Button)

Click this button to measure the right ascension motor index angle. When measuring the motor index angle, there can be no load on the motor, so you must remove the drive belt before proceeding.

Measure Dec (Dec Button)

Click this button to measure the declination motor index angle. When measuring the motor index angle, there can be no load on the motor, so you must remove the drive belt before proceeding.

Save Indices to Bisque TCS

Click the button to save the **RA Index** and **Dec Index** motor index angles to the Bisque TCS firmware. The motors and control system will not operate normally if the wrong motor index angles are saved, so please double-check these values before proceeding.

Get Current

Click this button to reads the current motor index angles from the control system.

Software Slew Limits

The typical or normal orientation of a GEM is when the optical tube assembly end of the declination axis is on one side of the pier when the observed object is on the opposite side of meridian. In this orientation, the counterweight shaft is “below horizontal” and the mount’s payload cannot collide with the side of the pier, so there is little risk of damaging your equipment.

Operating a GEM in an “atypical” orientation (see Figure 88), that is, when the optical tube assembly end of the declination axis and the observed object are on the same side of the meridian offers several advantages:

- An observed object can be tracked “through the meridian” without having to flip sides during the exposure. This maintains the orientation of the field of view. Switching sides rotates the image plane by 180 degrees.
- Guide stars do not have to be reacquired. Flipping sides requires reacquisition of the guide star when the mount slews to the “the other side of the pier”.

However, the significant disadvantage of operating a GEM in an atypical orientation is that the mount’s payload can collide with the side of the pier. While the Paramount’s control system is current limited so that running into a fixed object will automatically stop slewing, and tracking, it is always best to keep your expensive optical equipment from running into *anything*.

The **Software Slew Limits** options allow the Bisque TCS software limits to be configured such that the payload of a GEM cannot encounter the side of the pier.

After mounting the payload (camera, optical tube assembly and other equipment) to the Versa-Plate, use the hand controller or joystick to orient the mount in the non-standard GEM orientation. The counterweights will be “above horizontal” and the payload will run into the side of the pier at some declinations.

In order to properly configure the software slew limits the mount must be oriented at the “maximum slew position” in both right ascension and declination. Start by turning tracking off (choose the **Turn Tracking**

Off command from the Tools pop-up menu on the **Telescope** window) to ensure the mount stays at the limit position.

Next, use the hand controller or joystick to carefully slew the right ascension axis until the mount is in the abnormal position, without running the equipment into the side of the pier. You know the right ascension axis is oriented at the maximum slew position after slewing the declination axis 180 degrees always clears the side of the pier by at least one inch.

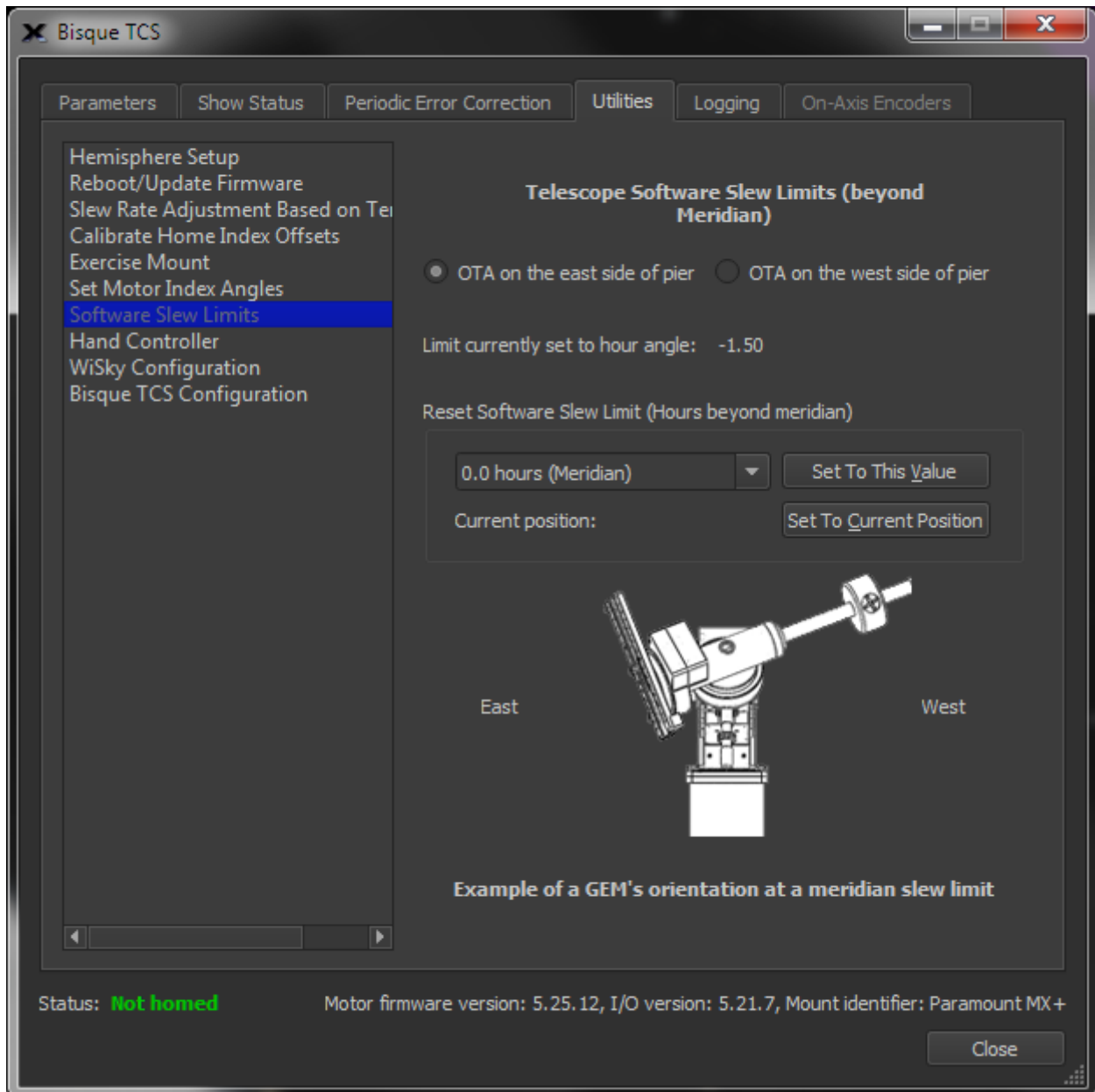

Figure 88: The Software Slew Limits settings on the Utilities tab.

OTA on the East Side of Pier

Turn this option on to set the slew position limit when the optical tube assembly is on the East side of the pier. Once the desired slew limit position is determined, click the **Set to Current Position** button to save this limit to the mount’s firmware.

OTA on the West Side of Pier

Turn this option on to set the slew position limit when the optical tube assembly is on the West side of the pier. Once the desired slew limit position is determined, click the **Set to Current Position** button to save this limit to the mount’s firmware.

Limit Currently Set To Hour Angle

This text box shows the control system’s current hour angle for the software slew limit for the selected axis.





Reset Software Slew Limit (Hours Beyond Meridian)



Use this group of controls to configure the mount’s software slew limit hour angle. For example, when a GEM is tracking near the meridian, at what hour angle should tracking be halted to prevent the possible collisions or equipment damage? Additionally, when commanded to slew from *TheSkyX Professional Edition*, should the OTA switch sides of the pier when the destination of a target object is on the opposite side of the meridian? See “Hour Angle” on page 19 for more information about this topic.

Hours Beyond Meridian Pop Up Menu

The combination text box and pop-up menu, immediately to the left of the **Set To This Value** button, can be used to either manually enter the “hour angle hours” for the software slew limit, or to choose from one of the default values in the list. Click the **Set To This Value** button to permanently save this setting to the control system’s firmware.

The table below shows lists Paramount model specific maximum hour angle. The Paramount ME II has configurable “hard stop positions” (page 92) and the maximum hour angle depends on the position of the hard stop bolts.

	Hard Stop Position	Hour angle (hours)
	1	2.8
	2	2.3
	3	1.8
	4	1.3
	5	0.8
	6	0.3
	Hard stop bolt removed	3.2
	0.33 hours	
	2.5 hours	
	2.5 hours	

	Hard Stop Position	Hour angle (hours)
	1	2.8
	2	2.3
	3	1.8
	4	1.3
	5	0.8
	6	0.3
	Hard stop bolt removed	3.2
	0.33 hours	
	2.5 hours	



Choose the **Save All Parameters To Mount** command from the **Commands** pop-up menu on the **Parameters** tab of the **Bisque TCS** window to save the slew limits settings.



The software slew limits must be reconfigured when the **Restore Defaults** command (page 137) is issued. You may wish to write down the hour angle of the software slew limit so that it can be reset if necessary.

Set To This Value

Click this button to use the mount’s current position to define the software slew limit.

Set To Current Position

Click this button to use the mount’s current mechanical position to define the slewing and tracking limit. If the payload might collide with the side of the pier, for example, first slew the mount to the “post collision” position, then click the button. To gain confidence that the slew limit is actually working, use the hand controller to try to slew the mount (at the slowest slew rate) past the limit. A properly defined software limit will automatically stop the slew, even when the mount is commanded from the hand controller.

Mount At Slew Limit Graphic

The mount graphic on the bottom of the **Software Slew Limits** pane is intended to convey an *example* of the orientation of the Paramount mount at the east and west meridian slew limits. This graphic is *not* intended to be “model specific” (in other words, the graphic that represents the mount will be the same for any Paramount model mount selected in the *TheSkyX Professional Edition’s Telescope Setup* window).

Hand Controller Settings

The four slew rates on the Hand Controller slew rate switch can be configured from the **Hand Controller** settings on the **Utilities** tab.

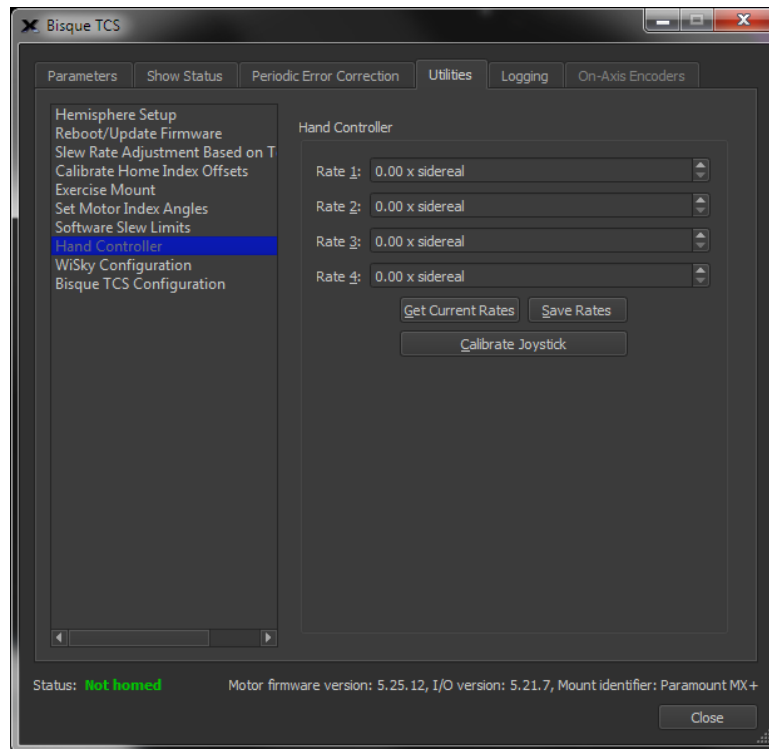

Figure 89: The Hand Controller settings on the Utilities tab.

Rate 1-4

Enter the desired slew rate for the corresponding rate position, based on the sidereal rate. For example, to configure switch Position 3 to slew the mount at 2 x sidereal rate, enter the number **2** in the **Rate 3** text box, then click the **Save Current Rates** button.

Get Current Rates

Click this button to retrieve the current slew rates from the control system.

Save Rates

Click this button to permanently save the current slew rates to the control system's firmware.

Calibrate Joystick

The MKS 4000 and MKS 5000 control systems both employ a mechanical joystick that can be used to slew the mount after homing, however, the purpose of joystick calibration differs significantly between these two control systems.

MKS 5000 Joystick Calibration

The MKS 5000 control system has an internal sensor that detects input from the joystick on the hand paddle. Clicking the **Calibrate Joystick** button initializes this sensor and saves the results to the mount's permanent internal memory.

When the joystick sensor is not properly calibrated, the **Find Home** command may fail unexpectedly and the telescope status text on the Telescope window will show *Not Homed*.

- MKS 5000 joystick calibration is performed at the factory, and should not need to be recalibrated unless you are instructed to do so by Software Bisque.
- The hand paddle does *not* need to be plugged in to the Electronics Box for successful joystick calibration.
- Before calibration can be performed, the mount should be turned on and connected to *TheSkyX Professional Edition*. No other mount or software initialization is necessary.

MKS 4000 Joystick Calibration

The **Calibrate Joystick** button determines the center position of the hand controller's joystick. If you plug in a new hand paddle, or the homing process fails unexpectedly, joystick calibration may be necessary.

Note that the MKS 4000 control system stops the homing process whenever the joystick is moved from the center position. When the joystick is not calibrated properly, homing will also fail because the control system "thinks" the joystick is not centrally located.

To calibrate the joystick:

1. Plug the hand paddle cable into the **Joystick** port on the Adaptor Panel.
2. Launch TheSkyX.
3. Click the **Connect** command from the **Telescope** menu to connect to the Paramount.
4. Choose the **Bisque TCS** command from the **Tools** pop-up menu on the **Telescope** window.
5. Highlight **Hand Controller** in the list on the left side of the **Utilities** tab on the **Bisque TCS** window.
6. Click the **Calibrate Joystick** button.
7. **Important!** Choose the **Save All Parameters To Mount** command from the **Commands** pop-up menu on the **Parameters** tab of the **Bisque TCS** window.

WiSky Configuration Settings

A Paramount with the MKS 5000 can be controlled with TheSkyX Professional Edition, or TheSky for iOS, via Wi-Fi using the optional WiSky plug in module. WiSky can be purchased exclusively on the Software Bisque Store here: <http://www.bisque.com/sc/shops/store/MK5KWiSky.aspx>. Setup by setup WiSky installation and configuration instructions are available in the *WiSky Installation and Use* PDF document here: <http://www.bisque.com/sc/media/p/96087.aspx>. An installation video is available here: <http://www.bisque.com/sc/media/p/95447.aspx>.

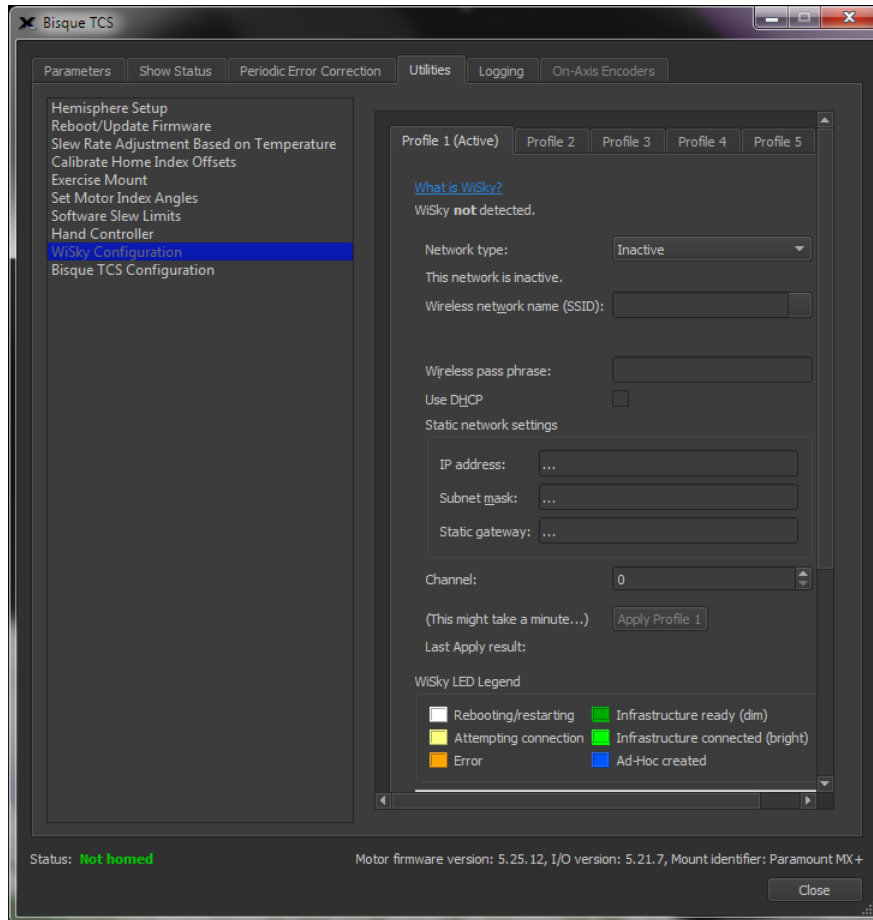

Figure 90: The WiSky Settings pane on the Utilities tab.

Bisque TCS Configuration

Click the **Configure the Bisque TCS** button on the **Bisque TCS Configuration** to configure control-system specific settings for non-Paramount mounts. This feature is intended for the Bisque TCS and Bisque TCS Professional systems, only. Do not use these settings to alter the Paramount control system’s settings!

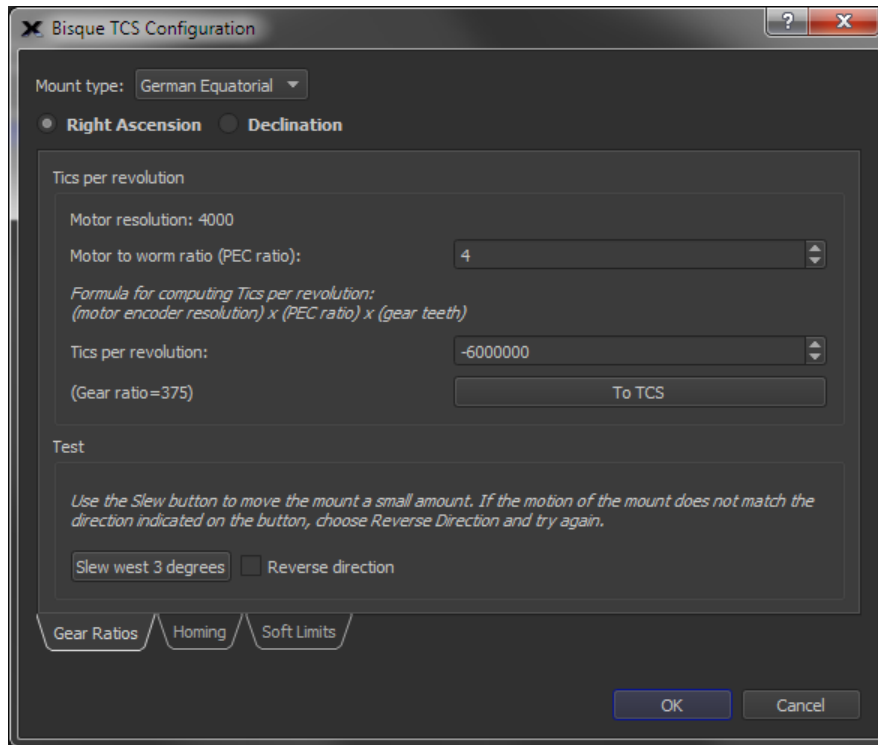

Figure 91: The Bisque TCS Configuration window is used to configure control-system specific settings for custom mounts.

On-Axis Encoders Tab (Paramount ME II only)

The Paramount ME II is available with option absolute, on-axis encoders. On-axis encoders eliminate the need to home the mount, and essentially eliminate periodic error caused by the worms and pulleys. The **On-Axis Encoder** tab provides a report that shows the status of the on-axis encoders, and the angular difference between motor’s encoders and the on-axis encoders. These values can be helpful for troubleshooting on-axis encoder issues.

Using ProTrack™

ProTrack™ is *TPoint-specific* software and *Paramount-specific* hardware technology that improves the Paramount’s tracking accuracy. ProTrack uses a pointing model to periodically issue small corrections telescope’s position that actually compensate for mechanical tracking errors, such as tube flexure and out of round gears as well as other systematic errors, such as atmospheric refraction and flexure of the declination axis. This same tracking enhancement technology is used on many of the world’s largest telescopes, such as the 8-meter Gemini telescope.

ProTrack gives amateur astronomers the ability to take long unguided exposures (up to 15 minutes or longer at 100-inch focal length are possible) with pinpoint stars. *Unguided exposures* of this duration at moderate to long focal lengths, with pinpoint stars, are simply not possible without *TheSkyX Professional Edition* software, Paramount control system hardware and MKS 5000 firmware integration.

ProTrack works best with a Super Model based on an extensive set of pointing calibration data set, and is typically used in permanent installations. However, ProTrack can provide useful tracking corrections using a smaller number of pointing samples, making it useful for semi-portable or mission critical portable setups.

ProTrack Minimum Requirements

ProTrack requires the following minimum hardware and software.

- A Paramount MyT, Paramount MX+, Paramount MX, Paramount ME, Paramount ME II, or MKS Series Software Bisque Telescope Control System (Bisque TCS).
- TheSkyX Professional Edition.
- TheSkyX Professional Edition's *TPoint Add On* (included with the Paramount mount).
- A fixed mirror telescope. (Errors due to mirror flop make high-accuracy tracking nearly impossible.)
- An extensive set of TPoint modeling data (100 to 200 stars or more recommended for Paramounts that do not use absolute, on-axis encoders).

Getting Started with ProTrack

A robust mount coupled with superb modeled telescope pointing is required for superb modeled telescope tracking. Here are the keys to getting excellent ProTrack results:

- Make sure every component of the imaging system is robust, from the pier mounting to the camera mounting and everything in between. Loose mechanics, or even poorly mounted cabling can introduce random errors that cannot be corrected by TPoint and therefore degrade ProTrack's performance.
- Use the *TPoint Add On's* Automated Pointing Calibration feature to obtain an accurate pointing calibration data set.
- Employ a TPoint Super Model that is based on a large number of pointing calibration samples.

Activating ProTrack

1. From *TheSkyX Professional Edition*, choose the **Connect** command from the **Telescope** menu to connect to the Paramount.
2. Turn on the **Activate ProTrack** checkbox on the **ProTrack** tab of the **TPoint Add On** window to view a table of ProTrack corrections that will be applied to tracking.
3. Turn on the **Enable Tracking Adjustments** checkbox to apply the corrections to the mount's position while tracking.

Details about the **ProTrack** tab on the **TPoint Add On** window can be found in the *TPoint Add On* User Guide.

Troubleshooting Mount Operation

Problem	Solutions
<p>TheSkyX Professional Edition cannot communicate with the Paramount, or displays communication error messages,</p> <p>“Error, poor communication, connection automatically terminated, Error = 213.”</p> <p>Or, when attempting to reconnect to the device, the error message:</p> <p>“Could not open communications port. The port is either in use by another application or not recognized by the system, Error = 201.”</p>	<p>Communication between a personal computer and hardware device requires that the software and hardware be properly configured. If you cannot establish a link to the telescope, please try the following:</p> <ol style="list-style-type: none"> 1. Make sure the mount is powered on. 2. Make sure the plugs on each end of USB 2.0 cable are seated properly. 3. Make sure the software settings are correct. 4. See “USB Hubs and USB Extenders ” on page 178. <p>By default, Microsoft Windows 7’s (and later) <i>power management plan</i> can suspend power to one or more USB devices connected to the computer (called USB Selective Suspend). Once power to the USB port is suspended, TheSky Pro will report communication errors, time out errors and potentially other unexpected device to PC transmission errors for any mount, camera, hub, or other USB device that is connected to this USB port.</p> <p>Edit the computer's power management settings to disable the USB Selective Suspend setting.</p> <ol style="list-style-type: none"> 1. Click Start > Control Panel and double-click the Power Options icon. 2. Click Edit Power Plan from the list of Power Options. 3. Click Change Advanced Power Settings on the Edit Plan Settings window. 4. On the Advanced Settings tab, expand USB Settings. 5. Expand USB Selective Suspend Setting. 6. Choose Disabled from the Settings pop-up menu. <p>Power management settings can be configured for individual USB ports.</p> <ol style="list-style-type: none"> 1. Click Start > Control Panel > Device Manager. 2. Expand Universal Serial Bus Controllers on the Device Manager window. 3. For the Generic USB Hub you wish to manage power settings, right-click, and choose the Properties command.

Problem	Solutions
	<ol style="list-style-type: none"> 4. Click the Power Management tab on the Generic USB Hub Properties window. 5. Turn off the Allow the Computer to Turn Off this Device to Save Power checkbox and click OK. <p> The Power tab on the Generic USB Hub Properties window lists the current power consumption requirements for the connected USB device. This information can be useful to ensure a USB device that is connected to the Paramount's Instrument Panel's USB hub does not exceed the maximum power specifications (page 72).</p> <p>Note that some users report that the above settings can change after a Windows update, so you may need to reapply these settings occasionally.</p> <p>To minimize issues related to operating-specific power management features, Software Bisque strongly recommends reviewing your computer's power plan before attempting to automate observatory control.</p>
<p>Paramount does not find the home position reliably. Sometimes the home position appears to be successfully located, other times not (resulting in successive beeps emitted by the control system).</p>	<p>The center position of the joystick on the hand controller may need to be calibrated.</p> <p>To Calibrate the Joystick</p> <ol style="list-style-type: none"> 1. Install TheSkyX Pro Latest Update: http://www.bisque.com/sc/media/p/45732.aspx. 2. Install TheSkyX Pro Daily Build (when available): http://www.bisque.com/sc/media/p/45603.aspx. 3. Launch TheSkyX. 4. Choose the Connect command from the Telescope menu. If prompted to find the home position, click No. 5. Choose the Bisque TCS command from the Tools menu on the Telescope window. 6. Click the Utilities tab. 7. Click Hand Controller on the left side of this window to reveal the Hand Controller pane. 8. Click the Calibrate Joystick button.
<p>The Paramount will not slew.</p>	<p>Make sure the Three Position Switches in both right ascension and declination are in the Track position (page 74).</p>

Problem	Solutions
<p>The Paramount emits continuous, successive, high-pitch “beeps” shortly after startup and will not slew.</p>	<ul style="list-style-type: none"> • Check that the balance knobs are adjusted properly. If the balance knobs are too tight, then the worm is forced against the gear, and the mount will not slew. • Check the mount balance in both axes. If the Paramount stalls or sounds labored while slewing, check to make sure both axes are properly balanced. Balance becomes more critical with heavier loads. While the control system has sufficient torque to lift heavy loads, tracking performance, and slewing, may suffer when the payload is greatly out of balance.

USB Hubs and USB Extenders

To achieve reliable communications between a computer and a USB device, the USB 2.0 specification states that the maximum cable length is about 16 feet (5 m). Longer cables introduce delays in the USB communication and means the computer cannot reliably “talk to” the attached device.

The Paramount is supplied with a standard USB cable that is roughly 15 feet (4.6 m) long and will reliably control the Paramount mount. Any other cable configuration can introduce unwanted behavior.

To control CCD cameras, Software Bisque strongly recommends using a dedicated 5m (16 ft.) USB cable plugged directly into the camera’s USB port and the computer’s USB port. The two USB ports on the Instrument Panel are part of a three port USB hub that is built into the MKS 5000 control system, and this hub can introduce unwanted behavior for example, communication failures, unreliable downloads, or artifacts on photos.

If you need a longer USB cable runs, Software Bisque strongly recommends using a USB extension solution from Icron Technologies (<http://www.icron.com>). They are expensive, but they work.

Software Bisque has experimented with many inexpensive USB extenders and most of them just *do not work*. Even worse, some work “some of the time” but often result in strange or unpredictable behavior.

After adding *any* USB extender to the Paramount, if you encounter *any* unusual behavior with the Paramount or device connected to the USB ports on the Instrument Panel, please see “Troubleshooting Communication Problems” below.

Controlling Multiple USB Devices with USB Hubs

Software Bisque cannot guarantee the Paramount will work with every possible USB/USB Hub/USB Extension/USB Device configuration. The number of hardware permutations is virtually unlimited, and, based on Software Bisque’s experience, USB extenders and USB hubs, even “industrial grade” hubs, can introduce communication problems.

For example, Software Bisque has encountered configurations where an “innocent looking” USB hub in the chain of computer/Paramount/Apogee Instruments CCD camera not only caused artifacts on the CCD photos, *TheSkyX Professional Edition* would lose communication when the camera download photos. No USB hub, no problems.

In another observatory, two of the ports on a four-port “industrial-grade” hub began to fail, and the driver would then terminate communications with the camera and focuser. Again, removing the hub and connecting all devices directly to the computer’s USB port solved the communication issue.

Again, Software Bisque has positive results powering multiple USB devices using the USB 2.0 Ranger Extenders from Icron Technologies. Expensive, but worth the investment.

Troubleshooting Communication Problems

Problem	How to Troubleshoot
<p>After adding a USB hub, USB cable extender or any other USB peripheral device to the Paramount USB cable, if <i>TheSkyX Professional Edition</i> is unable to connect to the Paramount (with frequent timeout errors or poor communication errors).</p>	<ul style="list-style-type: none"> • Remove the USB hub, or USB cable extender, and plug the 15-foot USB cable supplied with the Paramount directly into the computer’s USB port and port labeled USB on the Electronics Box. <p>Be wary of USB hubs, especially inexpensive or unpowered hubs. They can introduce intermittent communication failures and wreak havoc with your observing sessions.</p>

Windows and USB Port Power Settings

To minimize issues related to operating-specific power management features, Software Bisque strongly recommends reviewing your computer's power options before attempting to automate observatory control.

By default, Microsoft Windows can suspend power to USB devices connected to the computer. Once power is suspended, mounts, cameras and other USB devices that are connected to *TheSkyX Professional Edition* or the Camera Add On will report communication errors, time out errors and potentially other unexpected device to PC transmission errors.

To avoid this, edit the computer's power management settings and disable the USB Selective Suspend setting.

- Launch the Windows Control Panel and double-click the **Power Options** icon.
- Click **Edit Power Plan** from the list of **Power Options**.
- Click **Change Advanced Power Settings** on the **Edit Plan Settings** window.
- On the **Advanced Settings** tab, expand **USB Settings**.
- Expand **USB Selective Suspend Setting**.

- Choose **Disabled** from the **Settings** pop-up menu.
- Power management settings can be configured for individual USB ports.
- Click **Start > Control Panel > Device Manager**.
- Expand **Universal Serial Bus Controllers** on the **Device Manager** window.
- For the **Generic USB Hub** you wish to manage power settings, right-click, and choose the **Properties** command.
- Click the **Power Management** tab on the **Generic USB Hub Properties** window.
- Turn off the **Allow the Computer to Turn Off this Device to Save Power** checkbox and click **OK**.

Tips:

1. The **Power** tab on the **Generic USB Hub Properties** window lists the current power consumption requirements for the connected USB device. This information can be useful to ensure a USB device that is connected to the Paramount's Instrument Panel's USB hub does not exceed the maximum power specifications.
2. Some users report that the above settings can be changed after a Windows update, so you may need to occasionally reapply these settings.

Appendix A: Installing the MKS 5000 USB Windows Driver

When used with the Windows operating system, the Paramount MKS 5000 control system requires a one-time software driver installation before *TheSkyX Professional Edition* for Windows can be used to control the mount.

Windows USB Driver Installation and Use

The following procedure describes how to install the MKS 5000 USB driver under Windows 8, Windows 7 and Windows XP (32-bit and 64-bit editions) and configure *TheSkyX Professional Edition* to use this port once the driver has been installed.

1. From Windows Explorer, double-click the file named *MKS 5000 Driver Installer.exe* located in the *MKS 5000 Driver* folder on *TheSkyX Professional Edition* for Windows DVD you received with your mount.

This installer can also be downloaded from the Software Bisque web site from the following URL: <http://www.bisque.com/MKS5000>. Remember, you must sign in and *register your Paramount serial number* at www.bisque.com/register before your Software Bisque account can download this file.

2. Follow the installation instructions to complete the installation.
3. Once driver installation is complete, plug the USB 2.0 cable into the USB port on the Electronics Box and the USB 2.0 connector into a free USB port on the computer.



The Paramount must be turned on before the operating system will recognize the USB port on the Electronics Box and load the MKS 5000 driver.

4. Flip the Paramount power switch to the on position.
5. From *TheSkyX Professional Edition's* mount **Settings** window, select the COM port on the **Telescope > Telescope Setup > Mount Setup pop-up > Settings > Serial Port** list with the description **Software Bisque MKS 5000** (Figure 92).

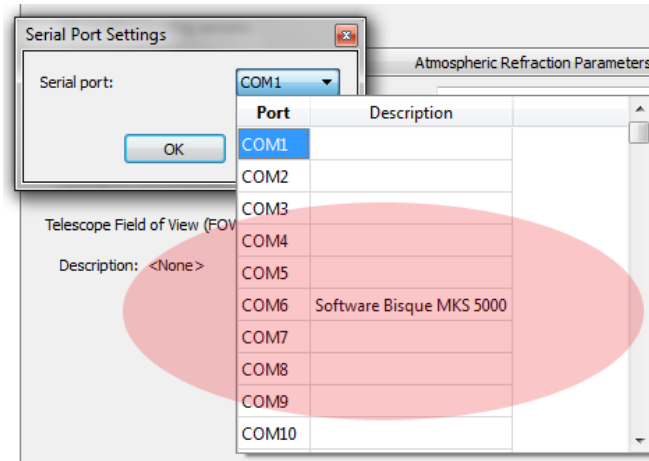

Figure 92: Selecting the COM port from *TheSkyX Professional Edition for Windows*.

The Windows Device Manager can also be used to determine the COM port number that is assigned to the MKS 5000.

Accessing Windows Device Manager

If necessary, use the Windows Device Manager to determine the COM port number that is assigned to the MKS 5000 driver, or to check the status of the driver.

Windows 8

1. Press the Windows Key+X.
2. Click the **Device Manager** command from the **Power User Menu**.

Windows 7 and Windows Vista

1. Click **Start**.
2. In the **Search Programs and Files** text box, type **Device Manager**, then click the magnifying glass graphic, or press **Enter**.

Windows XP

1. Click **Start > Settings > Control** and double-click the **System** icon.
2. On the **System Properties** window click the **Hardware** tab.
3. Click the **Device Manager** button on the **Hardware** tab.

With the Paramount's USB cable plugged in to the computer and into the mount's USB port, expand the **Unknown USB Devices** node to view the COM port number: **Software Bisque MKS 5000 (COMN)**, where N represents the communications port number.

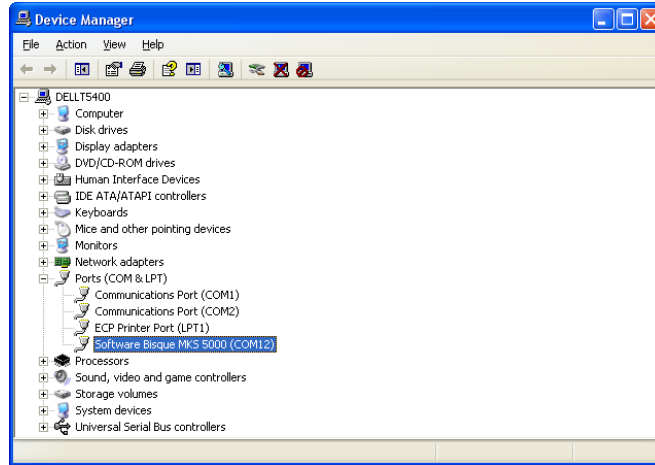

Figure 93: Windows XP Device Manager showing the COM port number assigned to the Paramount’s USB port.

Uninstalling the MKS 5000 Driver

The procedure below describes how to uninstall the MKS 5000 driver.

- Start Windows Device Manager. See “Accessing Windows Device Manager” above for your operating system.
- On the **Device Manager** window, expand **Ports (COM & LPT)**. Note that Windows Device Manager lists the driver only when the Paramount is turned on and a USB cable is plugged into the mount and the computer’s USB port.
- Right-click **Software Bisque MKS 5000 (COMN)**, where “N” is the COM port number that Windows assigned to the driver.
- Choose the **Uninstall** command from the pop-up menu (Figure 94).

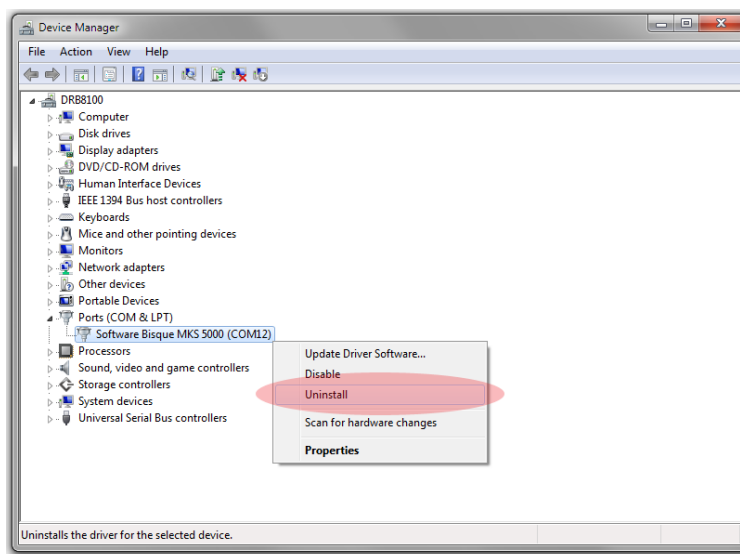

Figure 94: Uninstalling the MKS 5000 driver from the Device Manager.

- On the Confirm Device Uninstall window, turn on the Delete this driver software for this device checkbox if you wish to delete the drivers from the computer's hard drive, then click OK to finish.

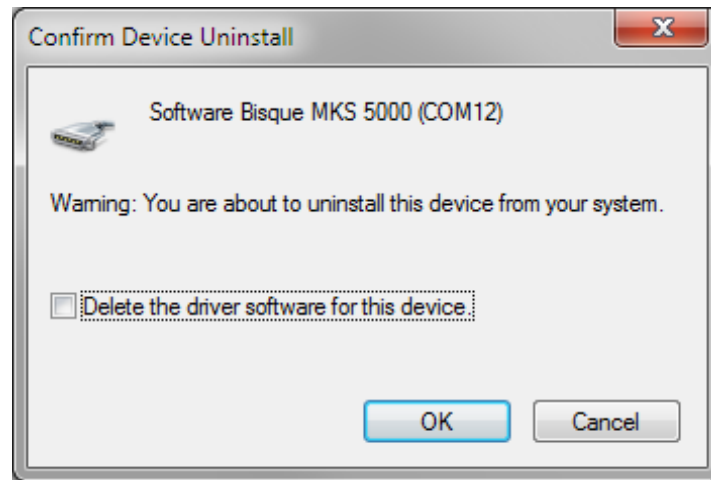

Figure 95: Confirm uninstallation.

The Software Bisque MKS 5000 driver is now uninstalled.

Appendix B: Paramount Technical Drawings

Technical drawings of many Paramount components are available in PDF format and can be downloaded from the Software Bisque web site. A SolidWorks eDrawing can also be used to determine many “non-standard” mount dimensions.

Click on the link below to visit the Software Bisque web page and download the drawing. Note that you must be signed in to the Software Bisque site to access these files. Windows users must install a PDF reader to view them. If the link below is not accessible, visit www.bisque.com, sign in, then click the Downloads link, then click the Documentation link in the left column of this page.

Name	URL of Drawing		
	MEII	MX MX	MYT
Base Plate to Pier Adaptor Plate	http://www.bisque.com/sc/media/p/28014.aspx	http://www.bisque.com/sc/media/p/45115.aspx	http://www.bisque.com/sc/media/p/104383.aspx
Basic Dimensions	http://www.bisque.com/sc/media/p/71810.aspx	http://www.bisque.com/sc/media/p/47243.aspx	http://www.bisque.com/sc/media/p/105132.aspx
Counterweight Shaft Extension Bar	http://www.bisque.com/sc/media/p/74385.aspx	http://www.bisque.com/sc/media/p/47380.aspx	http://www.bisque.com/sc/media/p/47380.aspx
Electronics Box	http://www.bisque.com/sc/media/p/48279.aspx	http://www.bisque.com/sc/media/p/48279.aspx	http://www.bisque.com/sc/media/p/48279.aspx
Instrument Panel	http://www.bisque.com/sc/media/p/48280.aspx	http://www.bisque.com/sc/media/p/48280.aspx	http://www.bisque.com/sc/media/p/48280.aspx
Paramount Wedge Assembly and Base Plate	http://www.bisque.com/sc/media/p/75443.aspx	http://www.bisque.com/sc/media/p/44777.aspx	–
Permanent Pier	http://www.bisque.com/sc/media/p/75436.aspx	http://www.bisque.com/sc/media/p/48198.aspx	http://www.bisque.com/sc/media/p/48198.aspx
Pier Mounting Options	–	http://www.bisque.com/sc/media/p/47058.aspx	–
Pier Top Plate	http://www.bisque.com/sc/media/p/47833.aspx	http://www.bisque.com/sc/media/p/47833.aspx	http://www.bisque.com/sc/media/p/47833.aspx

Name	URL of Drawing		
SolidWorks eDrawing	http://www.bisque.com/sc/media/p/66949.aspx	http://www.bisque.com/sc/media/p/44932.aspx	http://www.bisque.com/sc/media/p/104375.aspx
Versa-Plate	http://www.bisque.com/sc/media/p/75171.aspx	http://www.bisque.com/sc/media/p/45114.aspx	http://www.bisque.com/sc/media/p/104373.aspx

Computing Dome Offset Distance

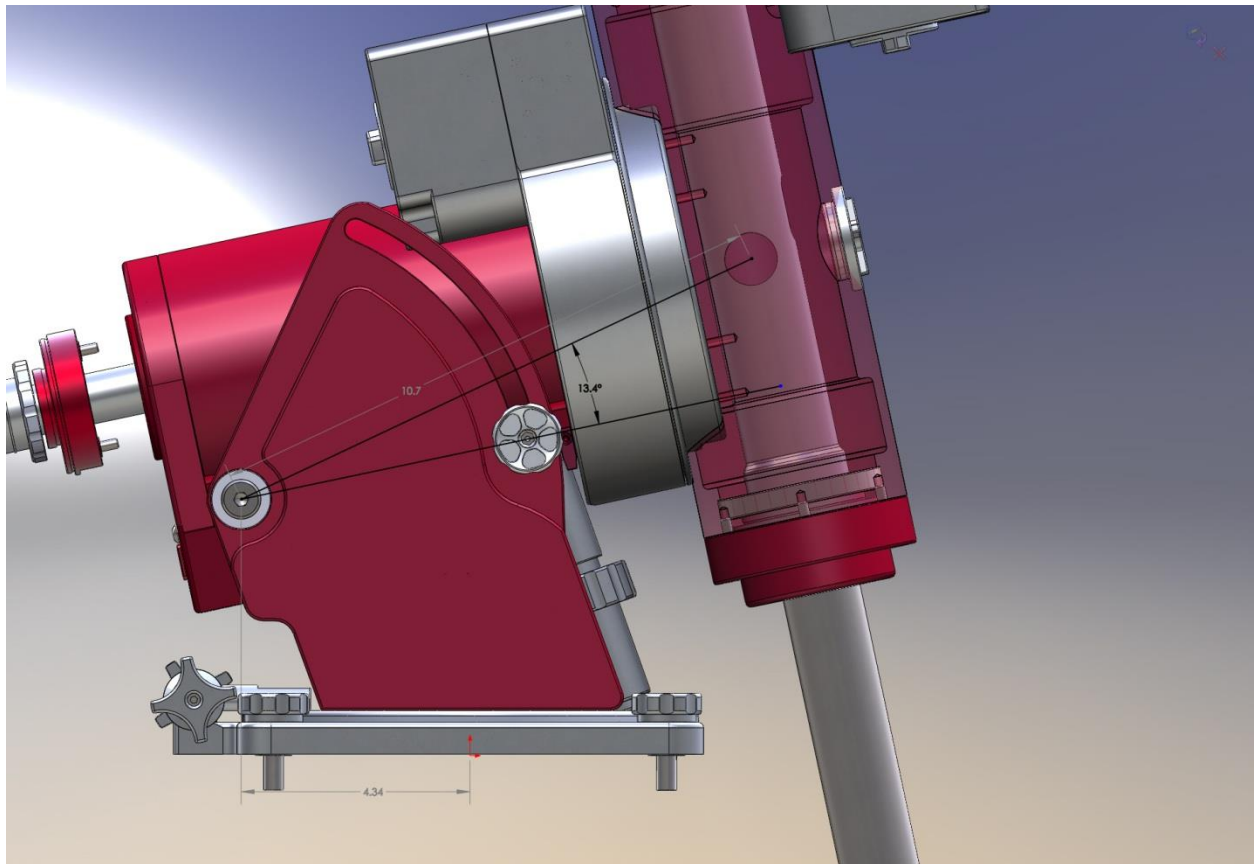







Figure 96: Diagram showing the derivation of dome offset equation for the Paramount MX or Paramount MX+.





You may wish to permanently mount your Paramount so that center of the dome is coincident with the center of the intersection of the mount's right ascension and declination axes.

One of the required measurements to do so is the distance from the center of the Paramount to the intersection of the mount's right ascension and declination axes (which changes with latitude).

Use the equations in the table below to compute the distance from the center point of the Paramount mount to the intersection of the right ascension and declination axes.

Model	Equation to Compute Distance (D)	
	in.	cm
	$D = 14 * \cos((\pi/180) * (\text{lat.} + 15.7^\circ)) - 4.8$	$D = 35.6 * \cos((\pi/180) * (\text{lat.} + 15.7^\circ)) - 12.2$
	$D = 14 * \cos((\pi/180) * (\text{lat.} + 15.8^\circ)) - 5.66$	$D = 35.6 * \cos((\pi/180) * (\text{lat.} + 15.8^\circ)) - 14.4$
 	$D = 11 * \cos((\pi/180) * (\text{lat.} + 13.7^\circ)) - 4.3$	$D = 27.9 * \cos((\pi/180) * (\text{lat.} + 13.7^\circ)) - 10.9$
	$D = 9.4 * \cos((\pi/180) * (\text{lat.} + 14.7^\circ)) - 3.65$	$D = 23.9 * \cos((\pi/180) * (\text{lat.} + 14.7^\circ)) - 9.3$

The table below shows the distance to the base center over a range of latitudes.

Latitude (°)	Distance to Base Center (cm/in.)			
				
10	19.9/7.8	17.6/6.9	14.7 /5.8	12.4/4.9
13	19/7.5	16.8/6.6	14.0/5.5	11.9/4.7
16	18.1/7.1	15.8/6.2	13.3/5.3	11.3/4.4
19	17.1/6.7	14.8/5.8	12.6/5.0	10.6/4.2
22	16/6.3	13.7/5.4	11.8/4.6	9.9/3.9
25	14.8/5.8	12.5/4.9	10.9/4.3	9.1/3.6
28	13.5/5.3	11.3/4.4	9.9/3.9	8.3/3.3
31	12.2/4.8	10.0/3.9	8.9/3.5	7.4/2.9
34	10.8/4.3	8.6/3.4	7.9/3.1	6.5/2.6
37	9.4/3.7	7.1/2.8	6.8/2.7	5.5/2.2
40	7.9/3.1	5.6/2.2	5.6/2.2	4.5/1.8
43	6.3/2.5	4.0/1.6	4.4/1.7	3.5/1.4
46	4.7/1.8	2.4/1.0	3.2/1.2	2.4/1.0
49	3/1.2	0.8/0.3	1.9/0.7	1.3/0.5

Latitude (°)	Distance to Base Center (cm/in.)			
52	1.3/0.5	-0.9/-0.4	0.6/0.2	0.2/0.1
55	-0.4/-0.2	-2.7/-1.1	-0.8/-0.3	-1.0/-0.4
58	-2.2/-0.9	-4.5/-1.8	-2.1/-0.8	-2.2/-0.9
61	-4.0/-1.6	-6.3/-2.5	-3.5/-1.4	-3.4/-1.3
64	-5.8/-2.3	-8.1/-3.2	-5.0/-2.0	-4.6/-1.8
67	-7.7/-3.0	-9.9/-3.9	-6.4/-2.5	-5.8/-2.3

For the northern hemisphere, a positive value indicates that the intersection of the right ascension and declination axes is north of the center of the mount. A negative value indicates the intersection of the right ascension and declination axes is south of the center of the mount.

Appendix C: External Power Cable Sets

Software Bisque sells “sets of two cables” that can be used to supply power to a camera that is mounted on the optical tube assembly using the standard power supply from the manufacturer in conjunction with the External Power connectors on the Electronics Box (page 80) and the Instrument Panel (page 70).



The External Power connectors on the Instrument Panel and on the Electronics Box **do not supply power** nor do they have anything to do with the Paramount power supply.

These connectors act as a conduit to route an external power source that is connected to External Power connector located Electronics Box to the External Power connector in the Instrument Panel.

External Power Cable Sets can be purchased from the Software Bisque Store for Apogee/QSI cameras, SBIG ST-7 series (5-pin DIN) or ST-L series cameras (6-pin DIN). A “generic” cable set is available for conversion from other power sources and camera.

One end of the “bottom” cable plugs into the camera manufacturer’s power connector and the other end plugs into the External Power connector on the Electronics Box. One end of the “top” cable plugs into the External Power connector on the Instrument Panel and the other into the camera body.

Apogee/QSI/SBIG ST-402/STF-8300 Model Camera External Power Cable Set Specifications

Figure 97 shows the wiring specifications for the Apogee, QSI and newer SBIG model camera’s bottom cable. Figure 98 shows the specifications for the top cable in this set.

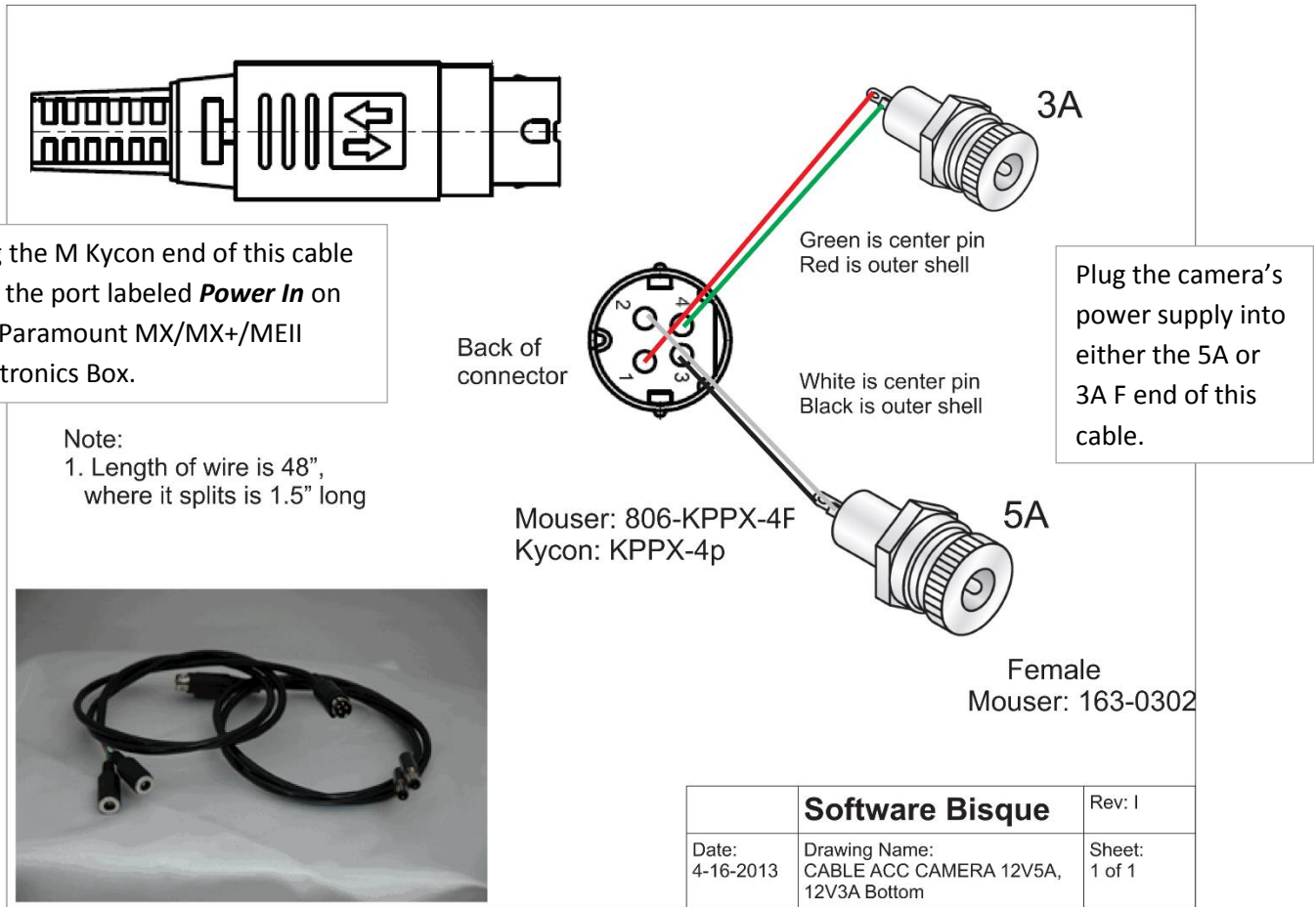

Figure 97: Apogee, QSI and newer model SBIG power connectors on the 36-inch (91 cm) bottom cable (wire color may vary).

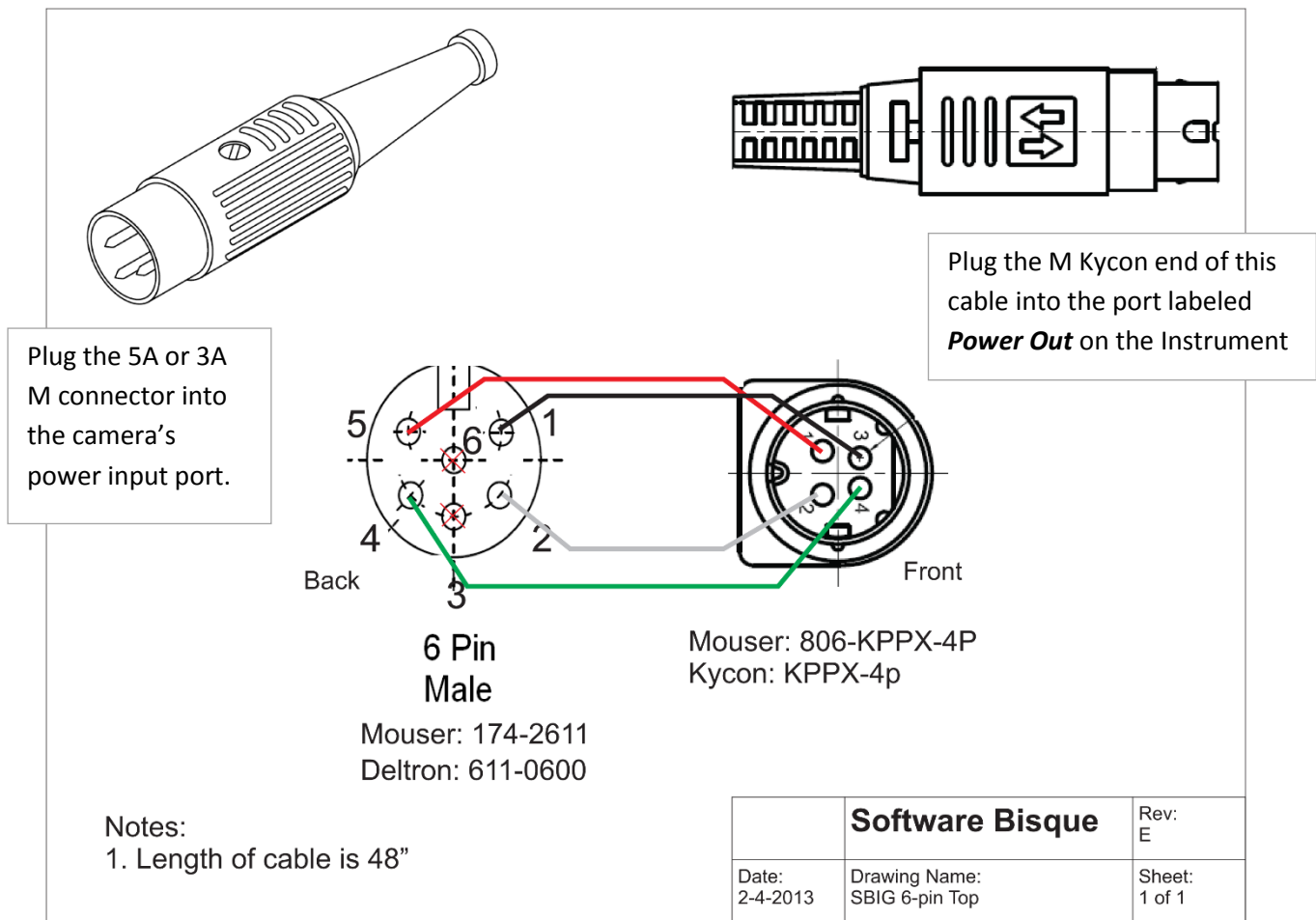

Figure 98: Apogee, QSI and SBIG ST-402 power connectors on the 36-inch (91 cm) top cable (wire color may vary).

Visit the URL below to purchase this cable from the Software Bisque Store:

<http://www.bisque.com/sc/shops/store/MXPowerCableApogeeQSI.aspx>

SBIG ST-7 Series (5-Pin) External Power Cable Set Specifications

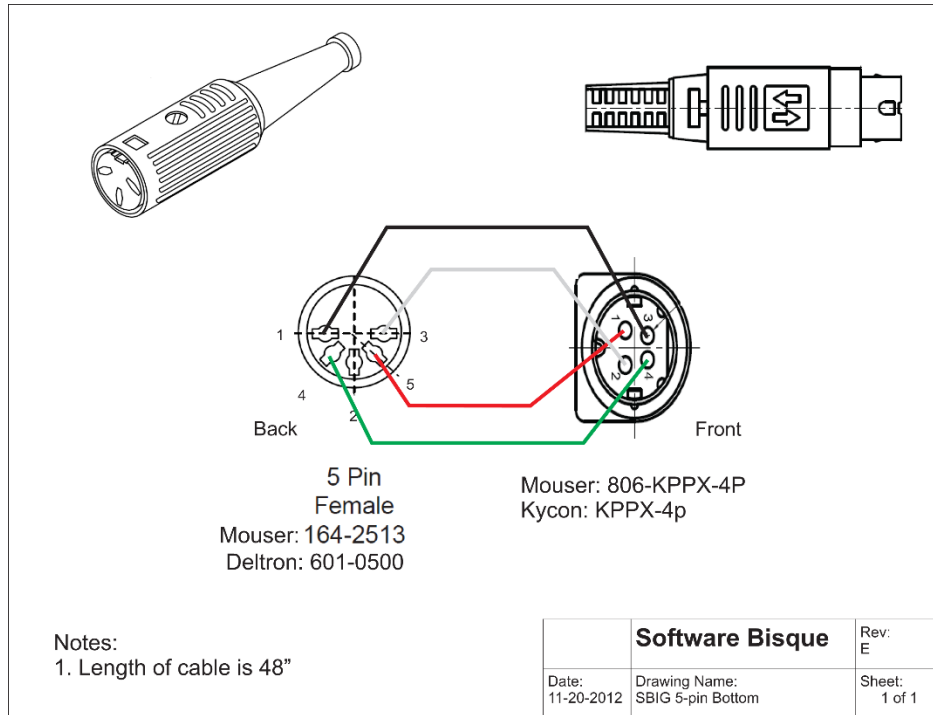

Figure 99 shows the wiring specifications for the SBIG ST-7 series 5-pin bottom cable (wire color may vary). Figure 100 shows the specifications for the top cable in this set.

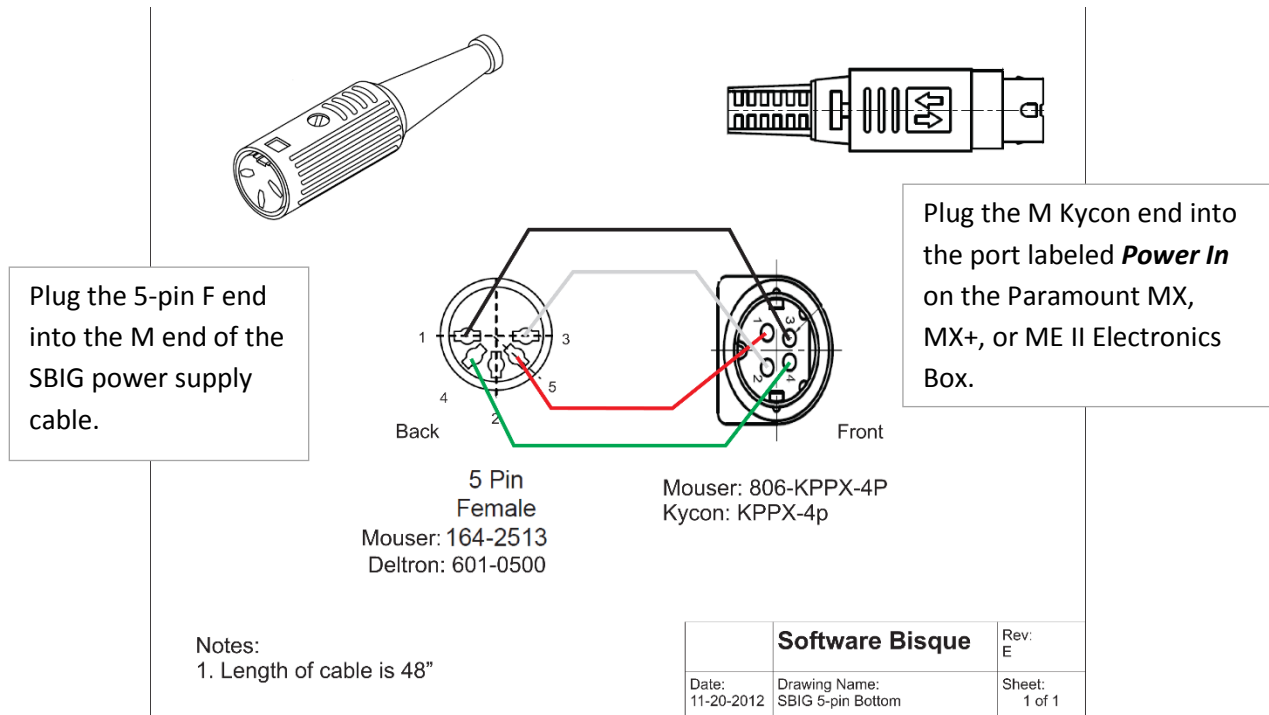

Figure 99: 5-pin SBIG ST-7 type power connectors on the 36-inch (91 cm) bottom cable (wire color may vary).

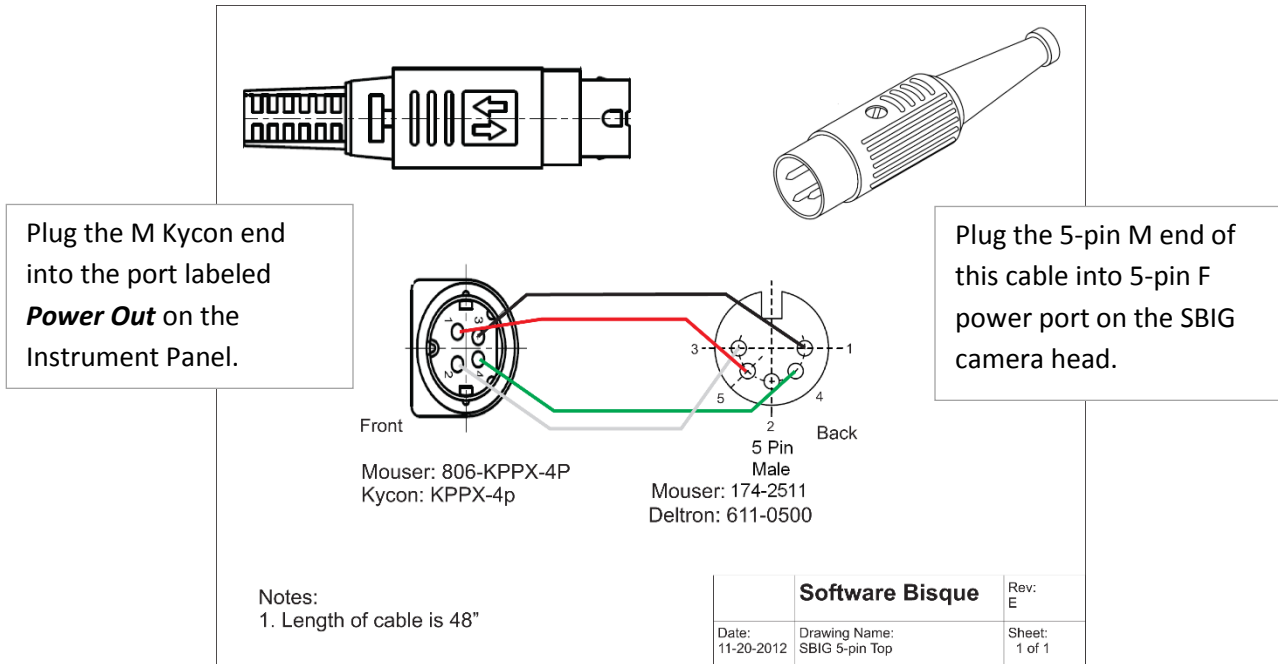

Figure 100: 5-pin SBIG ST-7 type power connectors on the 36-inch (91 cm) top cable (wire color may vary).

The SBIG ST-7 Series (5-Pin) External Power Cable Set is compatible with all SBIG camera models that use the 5-pin power connector.

Visit the URL below to purchase this cable from the Software Bisque Store:

<http://www.bisque.com/sc/shops/store/MXPowerCableSBIGST7.aspx>

SBIG ST-L Series (6-Pin) External Power Cable Specs

Figure 101 shows the wiring specifications for the SBIG STL series 6-pin bottom cable. Figure 102 shows the specifications for the top cable in this set.

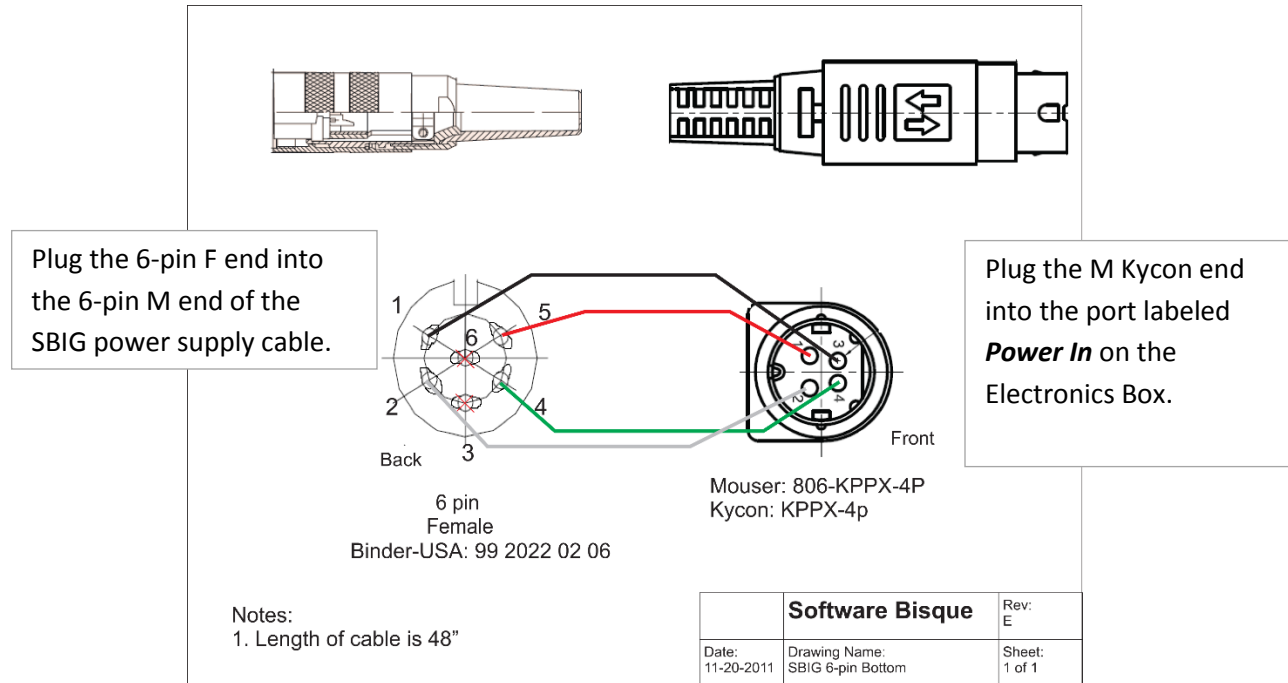

Figure 101: 6-pin SBIG ST-L type power connectors on the 36-inch (91 cm) bottom cable (wire color may vary).

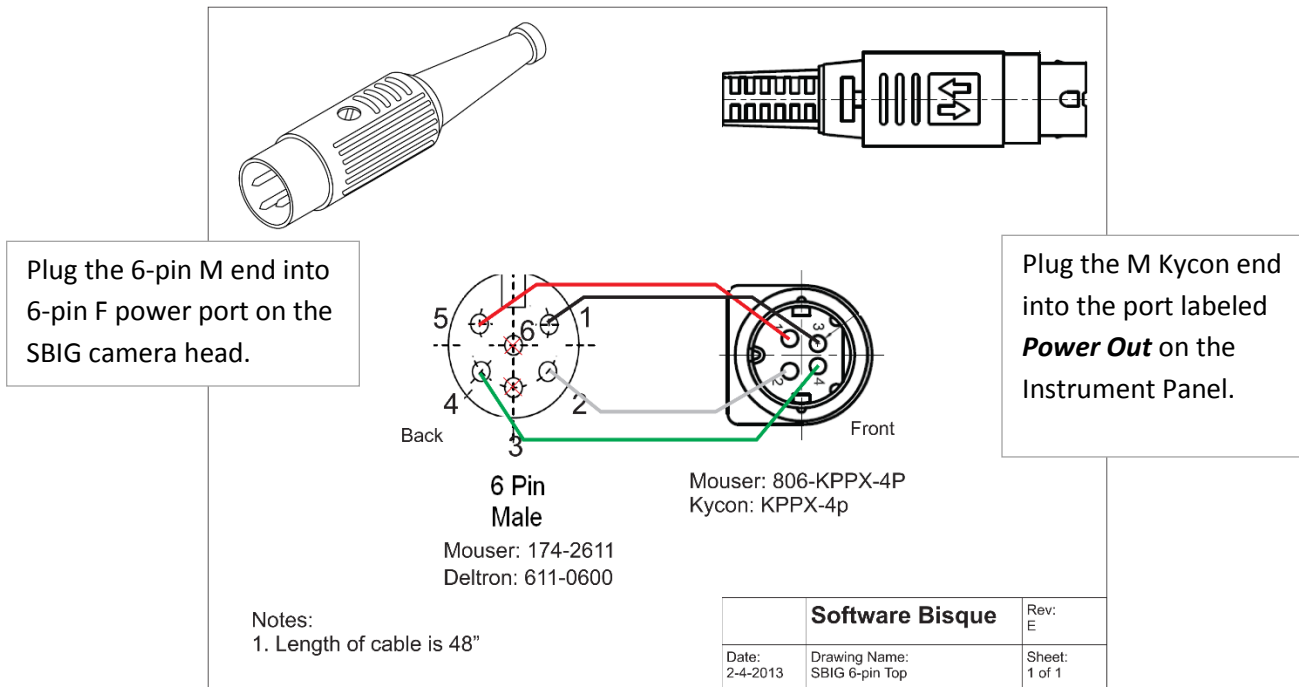

Figure 102: 6-pin SBIG ST-L type power connectors on the 36-inch (91 cm) top cable (wire color may vary).

The SBIG ST-L Series (6-Pin) External Power Cable Set is compatible with all SBIG camera models that use the 6-pin power connector.

Visit the URL below to purchase this cable from the Software Bisque Store:

<http://www.bisque.com/sc/shops/store/MXPowerSBIGSTL.aspx>

Finger Lakes Instruments External Cable Specs

The Finger Lakes Instruments power supply uses a four pin male Kycon connector that is normally plugged directly into the FLI camera head (see the port labeled *12V power supply in* in Figure 105).

To power an FLI camera using the Paramount’s built-in through the mount cabling, plug one end of the male-to-male FLI External Power Cable (Figure 104) into the port labeled *Power Out* on the Instrument Panel, and the other end into the port labeled *Power* on the FLI camera head (Figure 105).

Next, plug the male Kycon connector on the FLI power supply into the port labeled *Power In* on the Electronics Box.

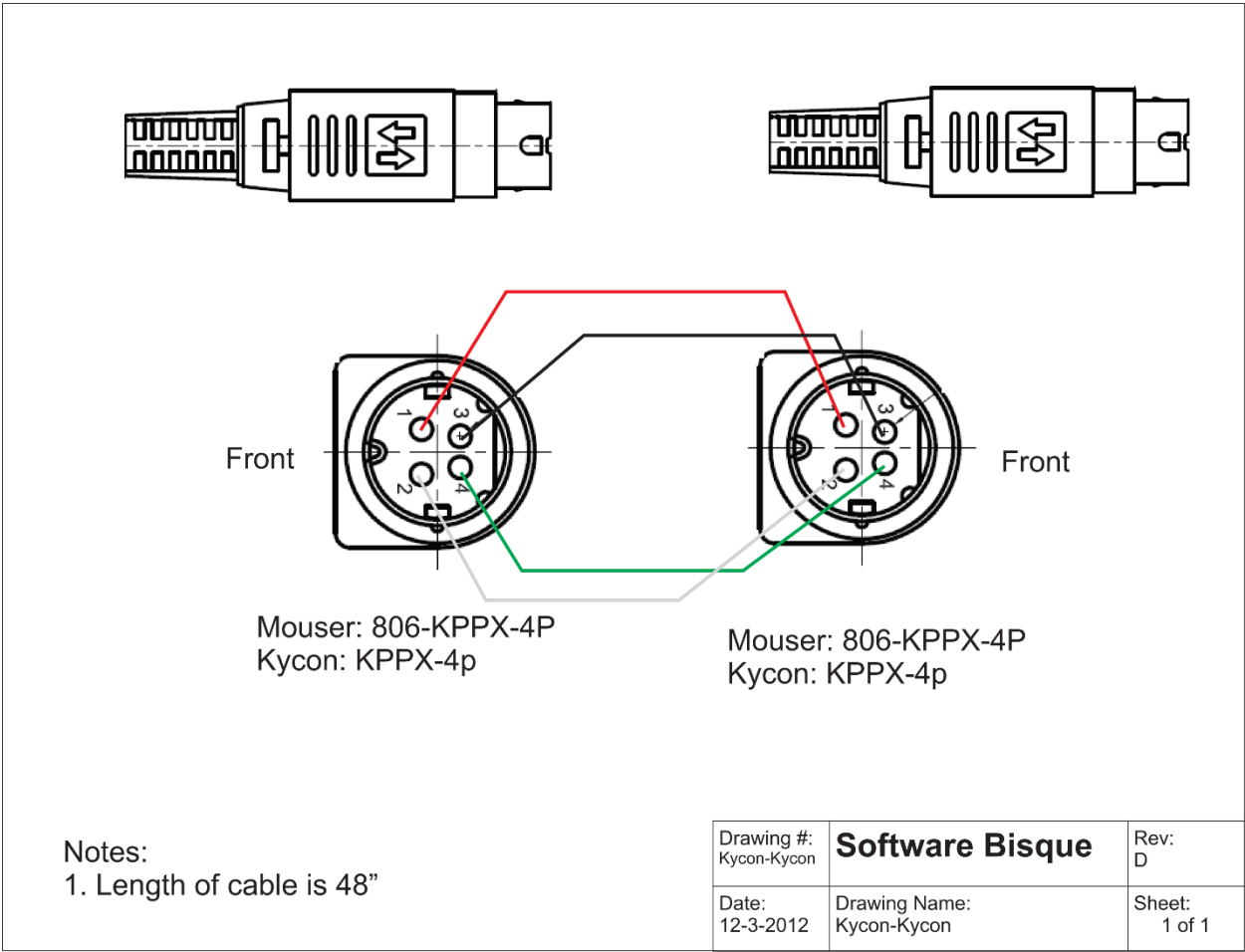

Figure 103: Finger Lakes Instruments external power cable wiring specifications (wire color may vary).



Figure 104: Photograph of the Finger Lakes Instruments external power cable.

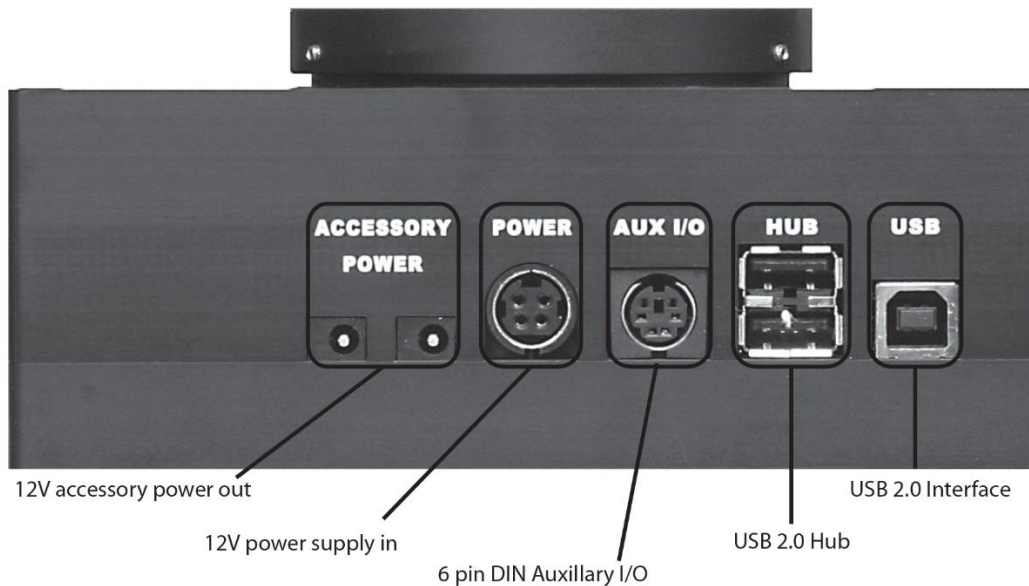

Figure 105: Finger Lakes camera input ports. Diagram copyright Finger Lakes Instruments.

Visit the URL below to purchase this cable from the Software Bisque Store:

<http://www.bisque.com/sc/shops/store/MXExtCableFLI.aspx>

Generic External Power Cable Specs

The generic external power cable set consists of two identical cables, one end incorporates the Kycon KPPX-4p connector and the other end terminates in four wires. How these four conductors are used is up to you!

Visit the URL below to purchase this cable from the Software Bisque Store:

<http://www.bisque.com/sc/shops/store/MXPowerCableGeneric.aspx>



Figure 106: Generic external power cables.

Appendix D: Paramount Warranty

Software Bisque warrants to the original owner that the Paramount will be free from defects in mechanical parts (for two years) and all electrical parts (for one year) from the date of delivery.

Software Bisque's limited warranty covers only those defects that are the result of normal use, and does not apply to any improper or inadequate maintenance or modification or operation outside the product's specifications.

If any component on the Paramount fails for any reason, please submit a post to the appropriate Paramount support forum at: www.bisque.com/support so that a support technician can assist in troubleshooting. Please also include the exact description of the problem as well as the exact wording of any error messages you encountered when connecting to or controlling the mount from TheSkyX Professional Edition.

If Software Bisque determines a replacement component is necessary, we will email you a Returned Merchandise Authorization (RMA) form. Once this form has been completed and returned, you will be issued an RMA number. When returning items, please clearly print the RMA number on the outside of shipping boxes; shipments received without an RMA number will be rejected.

The following section describes the warranty and non-warranty replacement policy and procedure for the MKS 5000 Electronic Board.

Product Return Procedure

Please visit www.bisque.com/warranty to read the Paramount warranty, and for details how to proceed if you need a replacement component or have a Paramount service request.

Appendix E: Revision History

The table below describes the changes in each revision of this user guide.

Revision Number	Changes
2.2	<ul style="list-style-type: none"> Attempted to improve the documentation related to the Paramount ME II declination axis spacer requirements when the Versa-Plate is in the wide orientation.
2.1	<ul style="list-style-type: none"> Added a reminder to save the software slew limits.
2.0	<ul style="list-style-type: none"> TheSkyX 10.5-related revisions.
1.98	<ul style="list-style-type: none"> Added documentation for the <i>Prohibit Tracking Below Horizon</i> Bisque TCS setting.
1.97	<ul style="list-style-type: none"> Updated USB port troubleshooting to include the Software Bisque Knowledge Base article number 1236.
1.96	<ul style="list-style-type: none"> Corrected incomplete sentence in Accurate Polar Alignment documentation. Updated warranty and the product return procedure documentation.
1.95	<ul style="list-style-type: none"> Updated the MKS 5000 firmware installation documentation.
1.94	<ul style="list-style-type: none"> Corrected the Paramount MYT and Paramount ME II metric dome offset equations in <i>Appendix B: Paramount Technical Drawings</i>.
1.93	<ul style="list-style-type: none"> Added additional MKS 5000 joystick calibration details.
1.92	<ul style="list-style-type: none"> Clarified differences between the MKS 4000 and MKS 5000 joystick calibration. Replaced the Paramount ME II graphic with the Paramount ME graphic in the tables in <i>Appendix B: Paramount Technical Drawings</i>.
1.91	<ul style="list-style-type: none"> Updated the motor index angle documentation for Paramount ME II, Paramount MX+ and Paramount MYT mounts.
1.90	<ul style="list-style-type: none"> Added WiSky and absolute encoders to the optional accessory list. Minor formatting changes and index additions.
1.89	<ul style="list-style-type: none"> Updated the document to include several missing graphics in the previous revision.

Revision Number	Changes
1.88	<ul style="list-style-type: none"> • In the PEC Teeth on Gear table, list the number of teeth in the declination gear for each model (for informational purposes only). • Clarified the Instrument Panel power port specifications. • Documented that the Dome Add On is now included with the Paramount ME II Software Suite. • Added 18 kg (40 lb.) counterweight to Paramount ME II optional accessory table. • Added Paramount Software Suite thumb drive to packing list.
1.87	<ul style="list-style-type: none"> • The Paramount MYT specification for peak to peak periodic error has been revised from 10 arcseconds to 7 arcseconds. • Corrected duplicate reference to Figure 70.
1.86	<ul style="list-style-type: none"> • Removed reference to incorrect PSU connector.
1.85	<ul style="list-style-type: none"> • Corrected the gauge of the through the mount wires. • Clarified the through the mount power usage with respect to DC and AC power sources. • Added additional information about USB hubs and USB communication failures.
1.84	<ul style="list-style-type: none"> • Corrected metric lengths of thrust mounting bolts, and specified the UNF thread specification. • When collecting tracking log data for periodic error correction, added a description of the location where autoguiding logs are saved. • Added the recommended minimum duration to collect tracking log data for the Paramount MYT. • Removed textual description for the Rough Polar Alignment Procedure which has been replaced by the Rough Polar Alignment command in <i>TheSkyX Pro</i>. • Clarified the Versa-Plate wide mounting orientation for the Paramount MYT.
1.83	<ul style="list-style-type: none"> • Added an explanation about the Paramount ME II declination axis spacers. • Updated the Paramount firmware installation process based on TheSkyX Pro Version 10.3.0 Build 8495 and later.
1.82	<ul style="list-style-type: none"> • Updated photo related to the generic cable set. • Added note to cable set wiring diagrams that wire cable may vary compared to the cable you receive.

Revision Number	Changes
1.81	<ul style="list-style-type: none"> Corrected the generic cable set documentation (these cables are no longer shielded).
1.79	<ul style="list-style-type: none"> Clarified the 12V and 5V Instrument Panel port documentation.
1.78	<ul style="list-style-type: none"> Corrected the number of Paramount MYT counterweights in the Packing List.
1.77	<ul style="list-style-type: none"> Added Paramount MYT documentation.
1.76	<ul style="list-style-type: none"> Corrected maximum altitude for Paramount ME II polar axis. Attempted to clarify the altitude tics for the Paramount ME II, Paramount MX/MX+ Altitude Scales.
1.75	<ul style="list-style-type: none"> Minor technical corrections.
1.74	<ul style="list-style-type: none"> Corrected joystick graphic documentation. Updated publish date.
1.73	<ul style="list-style-type: none"> Corrections and changes related to the Paramount MX+ documentation. Attempted to clarify how to properly power the Paramount ME II. Updated software slew limit documentation. Updated Bisque TCS documentation and reference WiSky Wi-Fi board.
1.72	<ul style="list-style-type: none"> Updated Documentation to include Paramount MX+ figures and specifications. Updated part number for mating the Switchcraft plug for the +5V DC and +12V DC on the Instrument Panel.
1.71	<ul style="list-style-type: none"> Added note about a minor design change in the Paramount MX cable conduit cover. Removed references to the discontinued Paramount MX ScopeGuard case.
1.70	<ul style="list-style-type: none"> Correct the technical drawing for the top SBIG ST-L External Power Cable.
1.69	<ul style="list-style-type: none"> Updated technical drawings for the through the mount power cables. Documented the Remove All button in the Synchronization History documentation.
1.68	<ul style="list-style-type: none"> Updated the procedure to install the MSK 5000 driver.

Revision Number	Changes
	<ul style="list-style-type: none"> • Updated FLI external power cable documentation. • Updated warranty policy and procedure.
1.67	<ul style="list-style-type: none"> • Added a photo to clarify Paramount MX declination axis through the mount cabling
1.66	<ul style="list-style-type: none"> • Corrected the PEC table index range for the Paramount ME II.
1.64	<ul style="list-style-type: none"> • Added Power Supply Extension Cable to packing list and attempted to clarify how to use this cable to supply power the Paramount ME II. • Updated technical drawing of the Electronics Box. • Added a reference to the Paramount Quick Start Guide document.
1.63	<ul style="list-style-type: none"> • Clarified the differences between the Paramount ME II and the Paramount MX with respect to the location of the Base Plate set screw access holes. • Corrected the description of the location of the physical hard stops on the Paramount ME II and the hours past the meridian specification
1.62	<ul style="list-style-type: none"> • Corrected the Paramount ME II vs. MX power supply specifications on page 84.
1.61	<ul style="list-style-type: none"> • Clarified that the Paramount ME II's Versa-Plate can be mounted in the Standard or Wide Orientation, similar to the Paramount MX.

Index

A	
absolute encoders	79
Adaptor plate	
wedge to pier	14
altitude	17
altitude adjuster	95
altitude adjuster thrust knobs	109
altitude scale.....	93
atmospheric refraction	20
azimuth	17
Azimuth adjustment knobs.....	84
B	
balance	
warning.....	104
base plate	86
set screws	86
base thrust mounting knobs.....	45, 86
Bisque TCS	
absolute home position	132
advanced settings.....	129
audible feedback	33
common settings.....	127
exporting settings.....	138
mount status	140
relative home position	130
restoring defaults	137
retrieving settings	138
saving settings	138
setting acceleration.....	127
setting non-sidereal rate	127
setting slew rate.....	127
settings	125
southern hemisphere setup	156
temperature	132
visual feedback.....	35
bubble level	110
C	
cable conduit	74
access hole	90
cables	
custom.....	36
mini-USB.....	45
power supply.....	46
camera	
power	189
carrying handle	
dec.....	90
Clock	
keeping accurate time.....	31
configure	
for southern hemisphere	156
coordinate systems.....	16
counterweight	101
counterweight balance.....	104
counterweight safety knob.....	46, 105
counterweight shaft	46
Counterweight shaft	
adding counterweights.....	102
counterweight shaft extension bar	101
counterweights.....	47
out of balance	103
Counterweights	
balancing payload	102
D	
dec	19
declination	19
declination assembly	92
Dimension 4 software.....	31
disclaimer	8
E	
Electronics box.....	79
LEDs	35
Electronics Box	
external power	189
equatorial coordinate system.....	17
external power	
connectors.....	189

External Power
 cable sets.....189

F

feedback
 audible.....33

finding home.....22

firmware version126

first time setup121

flashlight114

G

gears
 number of teeth134

GEM9

guider relay status140

H

HA19

hand controller46, 113

hand paddle
 changing rates114
 finding home113

hex keys45

hex wrench set115

home position
 absolute.....132
 absolute Dec.....157
 absolute HA157
 labeling24
 relative130
 relative HA.....157
 using hand paddle113

homing.....22

Homing
 periodic error correction23

horizon coordinate system16

hour angle.....19

I

install
 Windows drivers181

Instrument Panel70
 external power189

J

joystick status140

L

landing lights.....12, 114

Latitude adjustment wedge.....15

LEDs35

lighting
 turning on.....114

limited warranty198

local celestial meridian30

local sidereal time.....19

Local sidereal time31

LST.....19

M

mini USB cable114

MKS 3000.....120

MKS 3200.....120

MKS 4000.....120

MKS 5000.....120

mount identifier.....126

O

OTA
 defined27
 mounting hardware63

P

packing list42

Paramount
 physical dimensions of185

Paramount ME II
 worm period.....134

Park
 position.....32

Park position
 define32
 rules.....32

Parking31

period
 worm134

periodic error correction10, 142
 and homing23
 collecting tracking data148

polar align scope.....119

polar alignment
 precise alignment.....117
 using polar scope.....119

polar alignment scope
 mounting83
 power supply46
 power supply unit115
 ProTrack21
 activating175
 getting started175
 minimum system requirements175
 PSU115

R

RA18
 RA assembly79
 RA worm block cover73
 refraction20
 right ascension18

S

satellites
 tracking124
 serial number
 mount48
 Paramount ME II93
 Paramount MX93
 software48
 Server
 time31
 Set
 acceleration127
 fast pulse focus129
 maximum slew speed127
 non-sidereal rate127
 park position32
 slow pulse focus129
 tracking rates
 solar system objects130
 setup
 first time121
 southern hemisphere operation156
 sun warning8
 synchronization26
 best practices27
 checklist29
 from TheSkyX Professional Edition124
 purple region29
 red region29

starting over29
 step by step27
 verifying correct29

T

technical drawings185
 temperature
 compensated slew rate162
 TheSkyX Pro
 Bisque TCS window125
 mount status126
 TheSkyX Professional Edition
 setup124
 tracking spacecraft124
 three position switch74
 time
 maintaining accurate31
 Tips
 on parking position32
 troubleshooting
 control system audible feedback178
 Troubleshooting
 audible feedback33
 connecting to computer176
 homing177
 slewing177
 USB
 communication failures179
 Windows
 powering179

U

unboxing mount49
 USB
 driver
 installation122
 Mac OS122
 Windows122
 extenders178, 179
 hubs178
 troubleshooting communication failures179

V

vernal equinox18
 Vernier scale98
 Versa-Plate61

W

warning

- homing23
- observing sun8
- pinch point36, 91
- three position switch.....77
- unpacking mount49

wedge109

Wi-Fi.....15, 79, 172

Windows Device Manager182

wireless

- mount operation15, 79, 172

WiSky15, 79, 172

worm period134

Z

zenith distance.....20